

THIS DRAWING IS UNPUBLISHED.  
 VERTRÄULICHE UNVERÖFFENTLICHTE ZEICHNUNG  
 © COPYRIGHT BY TYCO ELECTRONICS CORPORATION. ALL RIGHTS RESERVED.  
 FREI FÜR VERÖFFENTLICHUNG  
 ALLE INTERNATIONALE RECHTE RESERVIERT.  
 ALLE RECHTE VORBEHALTEN

LOC	DIST	REVISIONS					
AI	-	P	LTR	DESCRIPTION	DATE	DWN	APVD
		B1		REVISION PER EG00-2081-00 (TEXT TO ENGLISH TRANSLATED)	06-SEP-00	R.S	G.F
		B2		REVISED PER ECR-09-018681	20AUG09	VKH	RRP

ORDER NO. BESTELL-NR.	CROSS SECTION QUERSCHNITT		STRIP LENGTH ABISOLIER-LÄNGE	TYPE AUSF?HRUNG	COLOUR FARBE	L <sub>1</sub> /mm	L <sub>2</sub> /mm	d <sub>1</sub> /mm	s <sub>1</sub> /mm	d <sub>2</sub> /mm	s <sub>2</sub> /mm	PACKING UNIT VERPACKUNGS-EINHEIT PARTS/STÜCK BAG/BEUTEL
	mm <sup>2</sup>	AWG										
966 067-1	0.50	20	8	SHORT KURZ	WHITE WEIß	12.0 ±1.5	6.0 ±0.4	1.0 +0.14	0.15 ±0.05	2.6 ±0.2	0.25 ±0.10	500
966 067-2	0.50	20	10	NORMAL NORMAL	WHITE WEIß	14.0 ±1.5	8.0 ±0.4	1.0 +0.14	0.15 ±0.05	2.6 ±0.2	0.25 ±0.10	500
966 067-3	0.50	20	12	HALFLONG HALBLANG	WHITE WEIß	16.0 ±1.5	10.0 ±0.4	1.0 +0.14	0.15 ±0.05	2.6 ±0.2	0.25 ±0.10	500
966 067-4	0.75	18	8	SHORT KURZ	GREY GRAU	12.0 ±1.5	6.0 ±0.4	1.2 +0.14	0.15 ±0.05	2.8 ±0.2	0.25 ±0.10	500
966 067-5	0.75	18	10	NORMAL NORMAL	GREY GRAU	14.0 ±1.5	8.0 ±0.4	1.2 +0.14	0.15 ±0.05	2.8 ±0.2	0.25 ±0.10	500
966 067-6	0.75	18	12	HALFLONG HALBLANG	GREY GRAU	16.0 ±1.5	10.0 ±0.4	1.2 +0.14	0.15 ±0.05	2.8 ±0.2	0.25 ±0.10	500
966 067-7	0.75	18	14	LONG LANG	GREY GRAU	18.0 ±1.5	12.0 ±0.6	1.2 +0.14	0.15 ±0.05	2.8 ±0.2	0.25 ±0.10	500
966 067-8	1.00	17	8	SHORT KURZ	RED ROT	12.0 ±1.5	6.0 ±0.4	1.4 +0.14	0.15 ±0.05	3.0 ±0.2	0.25 ±0.10	500
966 067-9	1.00	17	10	NORMAL NORMAL	RED ROT	14.0 ±1.5	8.0 ±0.4	1.4 +0.14	0.15 ±0.05	3.0 ±0.2	0.25 ±0.10	500
1-966 067-0	1.00	17	12	HALFLONG HALBLANG	RED ROT	16.0 ±1.5	10.0 ±0.4	1.4 +0.14	0.15 ±0.05	3.0 ±0.2	0.25 ±0.10	500
1-966 067-1	1.00	17	14	LONG LANG	RED ROT	18.0 ±1.5	12.0 ±0.6	1.4 +0.14	0.15 ±0.05	3.0 ±0.2	0.25 ±0.10	500
1-966 067-2	1.50	16	10	NORMAL NORMAL	BLACK SCHWARZ	14.0 ±1.5	8.0 ±0.4	1.7 +0.25	0.15 ±0.05	3.5 ±0.2	0.25 ±0.10	500
1-966 067-3	1.50	16	12	HALFLONG HALBLANG	BLACK SCHWARZ	16.0 ±1.5	10.0 ±0.4	1.7 +0.25	0.15 ±0.05	3.5 ±0.2	0.25 ±0.10	500
1-966 067-4	1.50	16	14	HALFLONG+ HALBLANG+	BLACK SCHWARZ	18.0 ±1.5	12.0 ±0.6	1.7 +0.25	0.15 ±0.05	3.5 ±0.2	0.25 ±0.10	500
1-966 067-5	1.50	16	20	LONG LANG	BLACK SCHWARZ	24.0 ±2.0	18.0 ±0.6	1.7 +0.25	0.15 ±0.05	3.5 ±0.2	0.25 ±0.10	500
1-966 067-6	2.50	14	10	NORMAL NORMAL	BLUE BLAU	14.0 ±1.5	8.0 ±0.4	2.2 +0.25	0.15 ±0.05	4.2 ±0.2	0.25 ±0.10	500
1-966 067-7	2.50	14	14	HALFLONG HALBLANG	BLUE BLAU	18.0 ±1.5	12.0 ±0.6	2.2 +0.25	0.15 ±0.05	4.2 ±0.2	0.25 ±0.10	500
1-966 067-8	2.50	14	20	LONG LANG	BLUE BLAU	24.0 ±2.0	18.0 ±0.6	2.2 +0.25	0.15 ±0.05	4.2 ±0.2	0.25 ±0.10	500
1-966 067-9	4.00	11	12	NORMAL NORMAL	GREY GRAU	17.0 ±1.5	10.0 ±0.4	2.8 +0.25	0.20 ±0.05	4.8 ±0.4	0.30 ±0.10	500
2-966 067-0	4.00	11	14	HALFLONG HALBLANG	GREY GRAU	20.0 ±1.5	12.0 ±0.6	2.8 +0.25	0.20 ±0.05	4.8 ±0.4	0.30 ±0.10	500
2-966 067-1	4.00	11	20	LONG LANG	GREY GRAU	26.0 ±2.0	18.0 ±0.6	2.8 +0.25	0.20 ±0.05	4.8 ±0.4	0.30 ±0.10	100
2-966 067-2	6.00	10	14	NORMAL NORMAL	YELLOW GELB	20.0 ±1.5	12.0 ±0.6	3.5 +0.30	0.20 ±0.05	6.3 ±0.4	0.30 ±0.10	100
2-966 067-3	6.00	10	20	LONG LANG	YELLOW GELB	26.0 ±2.0	18.0 ±0.6	3.5 +0.30	0.20 ±0.05	6.3 ±0.4	0.30 ±0.10	100
2-966 067-4	10.00	7	15	NORMAL NORMAL	RED ROT	22.0 ±2.0	12.0 ±0.6	4.5 +0.30	0.20 ±0.05	7.6 ±0.4	0.40 ±0.15	100
2-966 067-5	10.00	7	21	LONG LANG	RED ROT	28.0 ±2.0	18.0 ±0.6	4.5 +0.30	0.20 ±0.05	7.6 ±0.4	0.40 ±0.15	100
2-966 067-6	16.00	5	15	NORMAL NORMAL	BLUE BLAU	24.0 ±2.0	12.0 ±0.6	5.8 +0.30	0.20 ±0.05	8.8 ±0.4	0.40 ±0.15	100
2-966 067-7	16.00	5	21	LONG LANG	BLUE BLAU	28.0 ±2.0	18.0 ±0.6	5.8 +0.30	0.20 ±0.05	8.8 ±0.4	0.40 ±0.15	100
2-966 067-8	25.00	3	19	NORMAL NORMAL	YELLOW GELB	30.0 ±2.0	16.0 ±0.6	7.3 +0.40	0.20 ±0.05	11.2 ±0.5	0.40 ±0.15	50
2-966 067-9	25.00	3	21	HALFLONG HALBLANG	YELLOW GELB	30.0 ±2.0	18.0 ±0.6	7.3 +0.40	0.20 ±0.05	11.2 ±0.5	0.40 ±0.15	50
3-966 067-0	25.00	3	24	LONG LANG	YELLOW GELB	36.0 ±2.0	22.0 ±0.6	7.3 +0.40	0.20 ±0.05	11.2 ±0.5	0.40 ±0.15	50
3-966 067-1	35.00	2	19	NORMAL NORMAL	RED ROT	30.0 ±2.0	16.0 ±0.6	8.3 +0.40	0.20 ±0.05	12.7 ±0.5	0.40 ±0.15	50
3-966 067-2	35.00	2	21	HALFLONG HALBLANG	RED ROT	30.0 ±2.0	18.0 ±0.6	8.3 +0.40	0.20 ±0.05	12.7 ±0.5	0.40 ±0.15	50
3-966 067-3	35.00	2	28	LONG LANG	RED ROT	39.0 ±2.0	25.0 ±0.6	8.3 +0.40	0.20 ±0.05	12.7 ±0.5	0.40 ±0.15	50
3-966 067-4	50.00	-	25	NORMAL NORMAL	BLUE BLAU	36.0 ±2.0	20.0 ±0.6	10.3 +0.40	0.30 ±0.05	15.0 ±1.0	0.50 ±0.15	50
3-966 067-5	50.00	-	30	LONG LANG	BLUE BLAU	40.0 ±2.0	25.0 ±0.6	10.3 +0.40	0.30 ±0.05	15.0 ±1.0	0.50 ±0.15	50

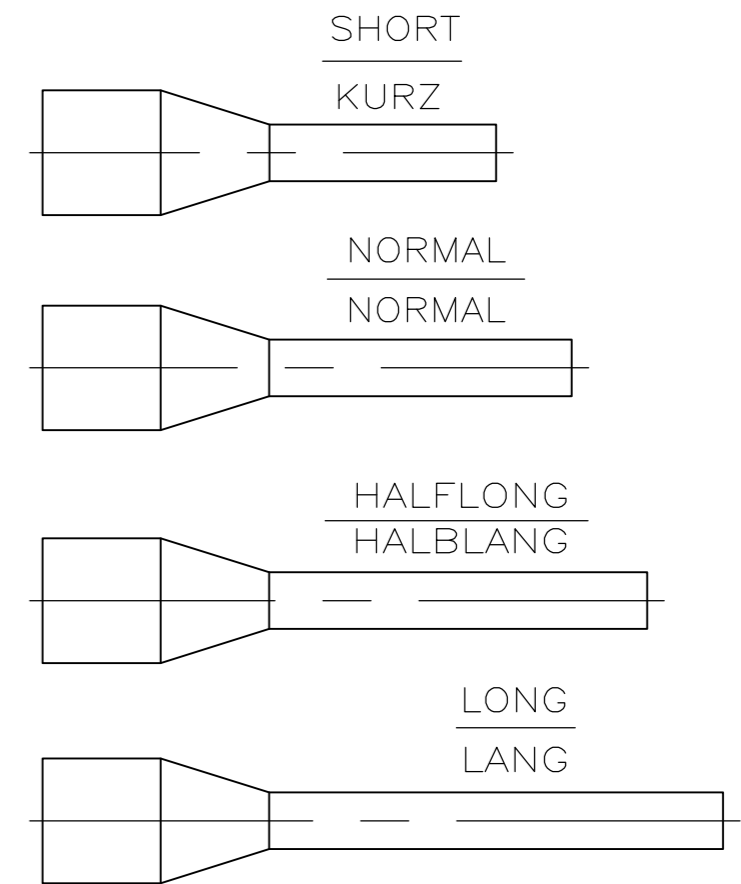
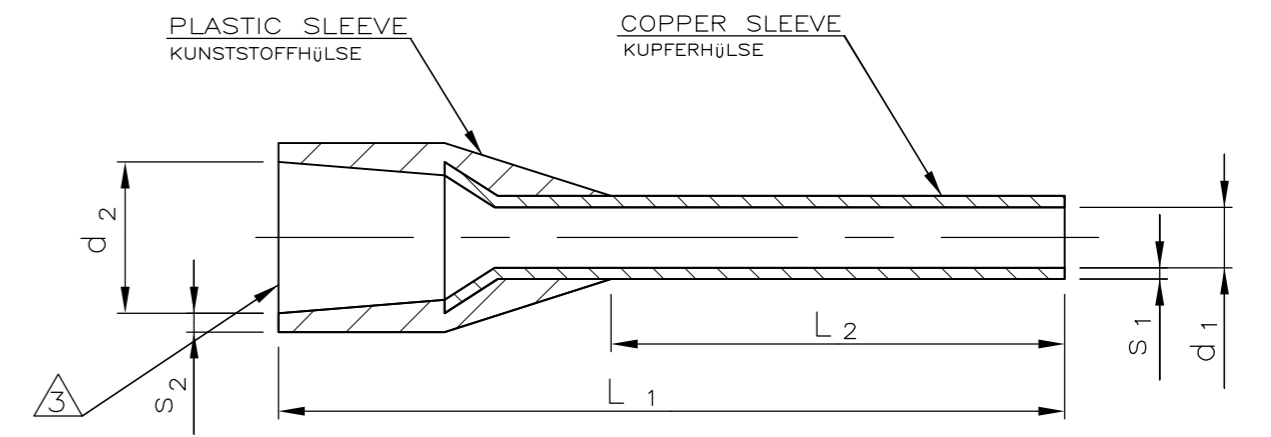

- 1 THE AWG CROSS-SECTION CAN SLIGHT DEVIATING OF THE DIN-STANDARD CROSS-SECTION VALUES
- 2 RECOMMENDED STRIP LENGTH
- 3 MAX. INSULATION-DIA. OF WIRE: d<sub>2</sub> MIN. - 0.1
- 4 TUBULAR END-SLEEVE WITH PLASTIC SLEEVE ACCORDING TO DIN 46228 PART 4
- 5. USE HAND TOOL 539660-1
- 1 DER AWG-QUERSCHNITT KANN VON DEN DIN-NORM QUERSCHNITTSWERTEN GERINGFÜGIG ABWEICHEN.
- 2 EMPFOHLENE ABISOLIERLÄNGE
- 3 MAX. ISOLATIONS-Ø DER LEITUNG: d<sub>2</sub> MIN. - 0.1
- 4 ADERENDHÜLSE MIT KUNSTSTOFFHÜLSE NACH DIN 46228 TEIL 4
- 5. BENUTZEN SIE HANDWERKZEUG 539660-1

THIS DRAWING IS A CONTROLLED DOCUMENT. DIESE ZEICHNUNG IST EIN KONTROLLIERTES DOKUMENT.		DWN R. Schmidt 14-NOV-96	Tyco Electronics AMP GmbH D - 64625 Bensheim	
DIMENSIONS: MASSENHITEN: mm		CHK W. Böck 14-NOV-96	TUBULAR END SLEEVE WITH PLASTIC SLEEVE	
TOLERANCES UNLESS OTHERWISE SPECIFIED: ALLGEMEINTOLERANZEN		APVD G.FELDMEIER 12-SEP-00	ADERENDHÜLSE MIT KUNSTSTOFFHÜLSE	
0 PLC ± - 1 PLC ± - 2 PLC ± - 3 PLC ± - 4 PLC ± - ANGLES/WINKEL ± -		PRODUCT SPEC VERÄNDERUNGSSPEZ.	SIZE A2	RESTRICTED TO NUR FÜR
MATERIAL PP/E-Cu		APPLICATION SPEC VERÄNDERUNGSSPEZ.	CAGE CODE 00779	REVISION B2
TOLERANCES UNLESS OTHERWISE SPECIFIED: n. ISO 8015 n. ISO 2768 - mH -E n. DIN 16901 - 140		FINISH/OBERFLÄCHE/FARBE Sn	DRAWING NO. ZEICHNUNGS-NR. C=966067	SCALE MASSSTAB
		WEIGHT GEWICHT	SHEET 1 OF 1	
		CUSTOMER DRAWING /KUNDENZEICHNUNG		