

These drawings and specifications are the property of DV3 Displays Ltd and may not be reproduced, copied or used without written permission

REVISIONS			
REV.	DESCRIPTION	DATE	APPROVED



DV3 Displays Ltd

www.dv3displays.com

Europe: +44 1959 542000

USA: +1 562 941 5000

Asia: +81 33767 9701

1. **Specification subject to change without notice.**
2. **All dimensions and specifications apply to standard modules. This information may vary for modules with optional features.**
3. **All dimensions are in millimetres.**
4. **Precautions: These precautions apply equally to modules from all makers, not just Densitron. Violation of these guidelines may void the warranty and can cause problems ranging from erratic operation to catastrophic display failure.**

Handling precautions:

?? This device is susceptible to Electro-Static Discharge (ESD) damage. Observe Anti-Static precautions.

Power supply precautions:

- ?? Identify and, at all times, observe absolute maximum ratings for both logic and LC drivers. Note that there is some variance between models.
- ?? Prevent the application of reverse polarity to VDD and VSS, however briefly.
- ?? Use a clean power source free from transients. Power up conditions are occasionally "jolting" and may exceed the maximum ratings of the module.
- ?? The +5V power of the module should also supply the power to all devices that may access the display. Don't allow the data bus to be driven when the logic supply to the module is turned off.
- ?? DO NOT install a capacitor between the VO (contrast) pin and ground. VDD must, at all times, exceed the VO voltage level. The capacitor combines with the contrast potentiometer to form an R-C network which "holds-up" VO, at power-down, possibly damaging the module.

Operating precautions:

- ?? DO NOT plug or unplug the module when the system is powered up.
- ?? Minimise the cable length between the module and host MPU. (Recommended max. length 30 cm).
- ?? For models with EL backlights, do not disable the backlight by interrupting the HV line. Unloaded inverters produce voltage extremes that may arc within a cable or at the display.
- ?? Operate the module within the limits of the modules temperature specifications.

Mechanical / Environmental precautions:

- ?? Improper soldering is the major cause of module difficulty. Use of flux cleaner is not recommended as they may seep under the elastomeric connection and cause display failure. Densitron recommends the use of Kester "245" no-clean solder.
- ?? Mount the module so that it is free from torque and mechanical stress.
- ?? Surface of LCD panel should not be touched or scratched. The display front surface is an easily scratched, plastic polariser. Avoid contact and clean only when necessary with soft, absorbent cotton dampened with petroleum benzene.
- ?? ALWAYS employ anti-static procedure while handling the module.
- ?? Prevent moisture build-up upon the module and observe the environmental constraints for storage temperature and humidity.
- ?? DO NOT store in direct sunlight.
- ?? If leakage of the liquid crystal material should occur, avoid contact with this material, particularly ingestion. If the body or clothing becomes contaminated by the liquid crystal material, wash thoroughly with water and soap.

Notes: (unless otherwise specified)

Unless otherwise specified: Dimensions are mm Tolerances are: X = ? 3 0.X = ? 0.5 0.XX = ? 0.05	APPROVALS	DATE	DV3 Displays Ltd BIGGIN HILL, ENGLAND	
	DRAWN			
	CHECKED		TITLE: 1x16 LCD module with optional backlight	
	ISSUED		DWG.NO.	DV2015 and DV4015

GENERAL SPECIFICATION

ITEM	CONTENTS
Display Format	16character(W) ×1line(H)
Character Size	3.07 ×6.56 mm
View Area	64.5 ×13.8 mm
General Dimensions	80.0 ×36.0 ×14.0 mm
LCD Type	<input checked="" type="checkbox"/> STN Gray <input type="checkbox"/> STN Yellow Green <input type="checkbox"/> STN Blue <input type="checkbox"/> FSTN Positive <input type="checkbox"/> FSTN Negative <input type="checkbox"/> TN
Polarizer mode	<input type="checkbox"/> Reflective <input checked="" type="checkbox"/> Transflective <input type="checkbox"/> Transmissive
View Angle	<input checked="" type="checkbox"/> 6 O'clock <input type="checkbox"/> 12 O'clock <input type="checkbox"/> Others_____
Backlight	<input checked="" type="checkbox"/> LED <input type="checkbox"/> EL <input type="checkbox"/> CCFL
Backlight Driver type	<input checked="" type="checkbox"/> Internal Power <input type="checkbox"/> External Power
Backlight Color	<input checked="" type="checkbox"/> Yellow green <input type="checkbox"/> White <input type="checkbox"/> Amber <input type="checkbox"/> Blue Green <input type="checkbox"/> Other
Controller/Driver	NT3881 or KS0066U
Temperature Range	<input type="checkbox"/> 0°C~+50°C <input checked="" type="checkbox"/> -20°C~+70°C <input type="checkbox"/> -30°C~+80°C
Character Font Table	<input checked="" type="checkbox"/> English <input type="checkbox"/> European <input type="checkbox"/> Other_____
DC/DC Converter	Without

MECHANICAL SPECIFICATION

ITEM	CONTENTS
Module Size	80.0(W) ×36.0(H) ×14.0max(D)
View Area	64.5 ×13.8 mm
Character Size	3.07mm ×6.56mm
Character Pitch	3.77mm
Dot Size	0.55mm ×0.75mm
Dot Pitch	0.63mm ×0.83mm
Duty Ratio	1/16 duty

ABSOLUTE MAXIMUM RATING(Ta=25°C VSS=0V)

Item	Symbol	Min.	Type	Max.	Unit	Humidity
Power Supply for Logic	V _{DD} -V _{SS}	-0.3	-	7.1	Volt	
Power Supply for LCD	V _{DD} -V _O	0	-	10.0	Volt	
Input Voltage	V _{IN}	-0.3	-	V _{DD} +0.3	Volt	
Supply Current for LED backlight	I _{LED}	-	-	220	mA	
Operating Temperature	Top	-20	-	+70	°C	Note1
Storage Temperature	Tst	-30	-	+80	°C	Note2

Note1: Background color changes slightly depending on ambient temperature. This phenomenon is reversible.

Ta ≤ 70°C: 75RH max

Ta > 70°C: absolute humidity must be lower than the humidity of 75%RH at 70°C

Note2: Ta at -30°C will be <48hrs, at 80 °C will be <120hrs when humidity is

ELECTRICAL CHARACTERISTICS (Ta=25°C)

Item	Symbol	Condition	Min.	Typ.	Max.	Unit
Power Supply for Logic	$V_{DD}-V_{SS}$	-	4.7	5.0	5.3	Volt
Input Voltage	V_{IL}	L level	V_{SS}	$0.2 V_{DD}$	-	Volt
	V_{IH}	H level	$0.7 V_{DD}$	-	V_{DD}	Volt
LCD Module Driving Voltage	$V_{DD}=5.0V$ $V_{DD}-V_O=4.2V$	Ta=-20°C	-	-	-	Volt
		Ta=0°C	-	-	-	
		Ta=25°C	3.9	4.2	4.5	
		Ta=50°C	-	-	-	
Power Supply Current for LCM	I_{DD} (B/L OFF)	$V_{DD}=5.0V$	-	1.5	3.0	mA
	I_{LED}	$V_{LED}=4.2V$	-	110	180	

OPTICAL CHARACTERISTICS

Item	Symbol	Min.	Typ.	Max.	Unit	Condition	Note
Viewing Angle	$\Theta 1-\Theta 2$	-15	--	45	deg.		1.2
	Φ	-35	--	+35	deg.		
Contrast Ratio	Cr	--	10	15	--	$\Theta=20^\circ$ $\Phi=0^\circ$	3
Response Time (rise)	Tr	--	250	750	ms	$\Theta=20^\circ$ $\Phi=0^\circ$	4
Response Time (fall)	Tf	--	300	900	ms	$\Theta=20^\circ$ $\Phi=0^\circ$	4

Note 1. Definition of angle Θ & Φ

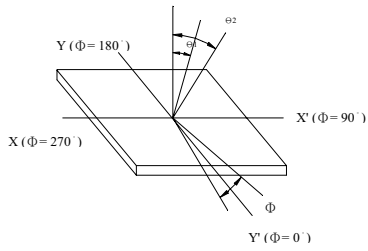

Note 2. Definition of viewing angle $\Theta 1$ & $\Theta 2$

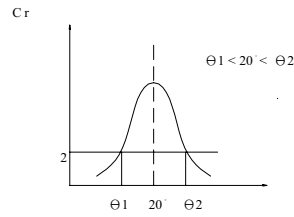

Note 3. Definition of contrast ratio (Cr)

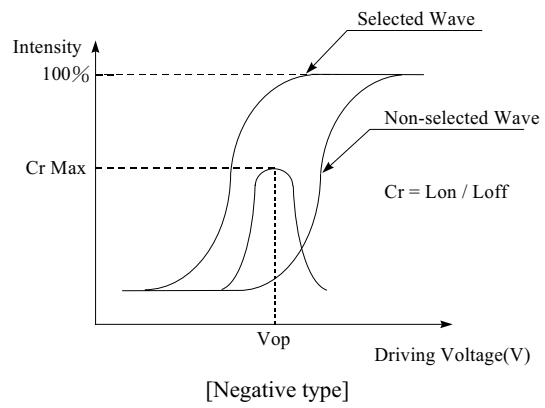
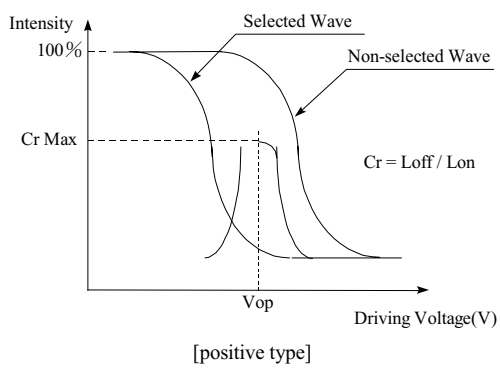

Note 4. Definition of response time

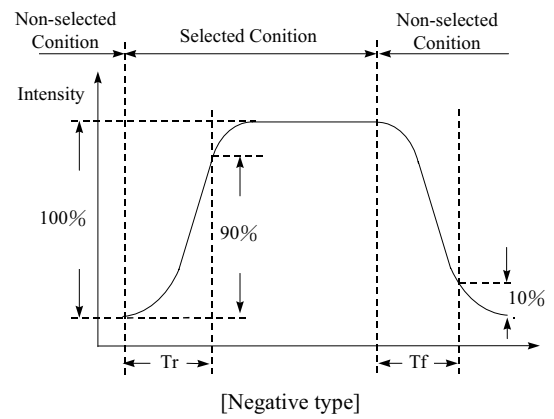
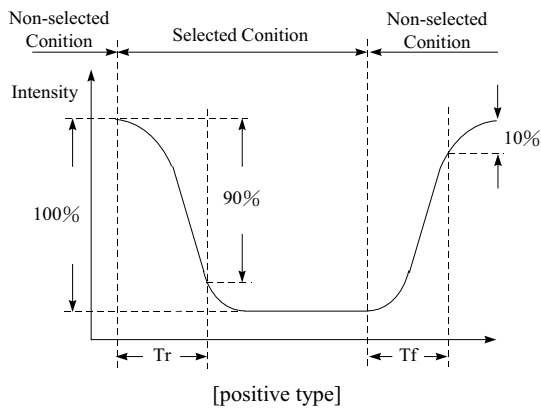

INTERFACE PIN ASSIGNMENT

PIN	SYMBOL	FUNCTIONS
1	VSS	GROUND (0V)
2	VDD	Powersupply for logic circuit (5V)
3	V0	Operating voltage for LCD driving (Variable)
4	RS	H : Data input ; L : Instruction code input
5	R/W	H : Data Read (LCM to MPU) ; L : Data Write (MPU to LCM)
6	E	Enable
7-14	DB0-DB7	Data bus line
15	NC	No connection
16	NC	No connection

BLOCK DIAGRAM

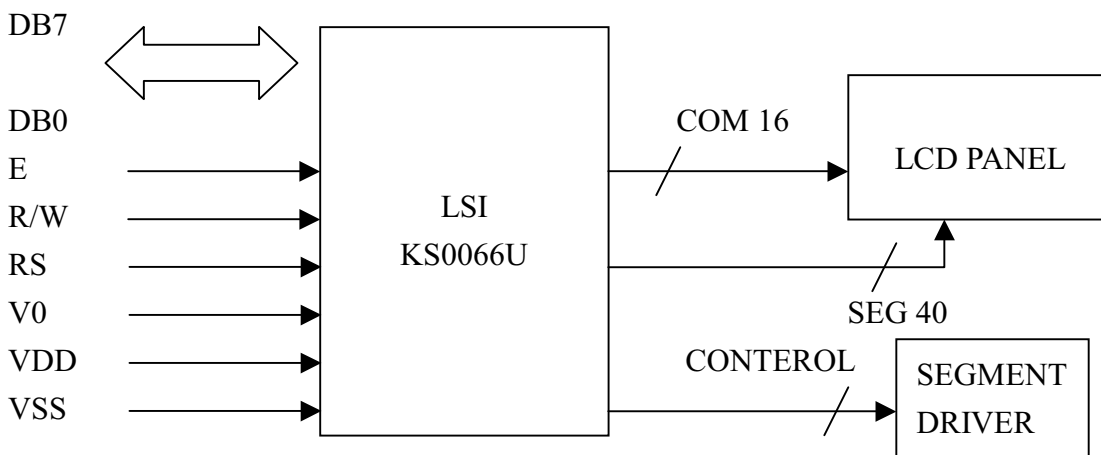

POWER SUPPLY

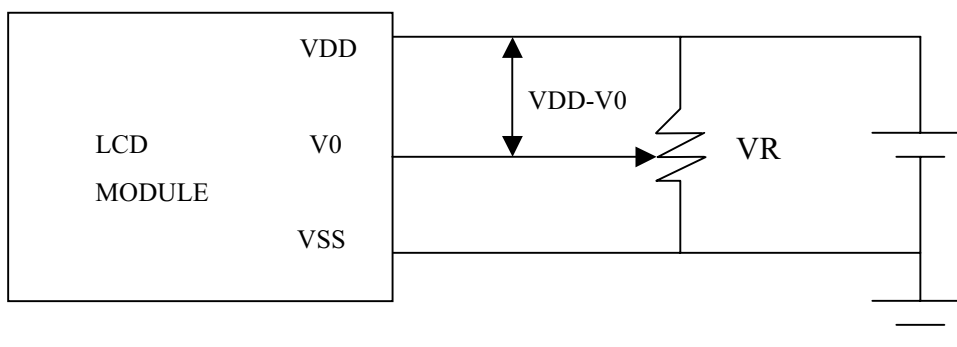

* VDD-V0 = Operating voltage for LCD

- VR = 10 Kohm to 20 Kohm

CHARACTER FONT TABLE

Upper 4 bits Lower 4 bits	0000	0001	0010	0011	0100	0101	0110	0111	1000	1001	1010	1011	1100	1101	1110	1111
0000	CG RAM (1)			0	A	P	`	F				—	9	E	op	P
0001	CG RAM (2)		!	1	A	a	a	a			a	7	7	4	ä	g
0010	CG RAM (3)		"	2	B	B	b	b			r	4	4	x	p	ø
0011	CG RAM (4)		*	3	C	S	S	S			J	7	7	E	E	æ
0100	CG RAM (5)		*	4	D	T	d	t			\	I	I	h	W	o
0101	CG RAM (6)		%	5	E	U	e	u			.	o	o	i	eu	ü
0110	CG RAM (7)		@	6	F	V	f	v			9	o	o	o	o	z
0111	CG RAM (8)		'	7	G	W	g	w			7	+	+	+	g	π
1000	CG RAM (1)		(8	H	X	h	x			4	o	o	o	o	z
1001	CG RAM (2))	9	I	Y	i	y			o	o	o	o	o	y
1010	CG RAM (3)		*	0	J	Z	j	z			o	o	o	o	o	z
1011	CG RAM (4)		+	1	K	K	k	k			o	o	o	o	o	z
1100	CG RAM (5)		,	2	L	Y	l	l			o	o	o	o	o	z
1101	CG RAM (6)		—	3	M	M	m	m			o	o	o	o	o	z
1110	CG RAM (7)		.	4	N	N	n	n			o	o	o	o	o	z
1111	CG RAM (8)		/	5	O	O	o	o			o	o	o	o	o	z