

max. 4,5 m³/h

DC axial fans

Series 250 25 x 25 x 8 mm

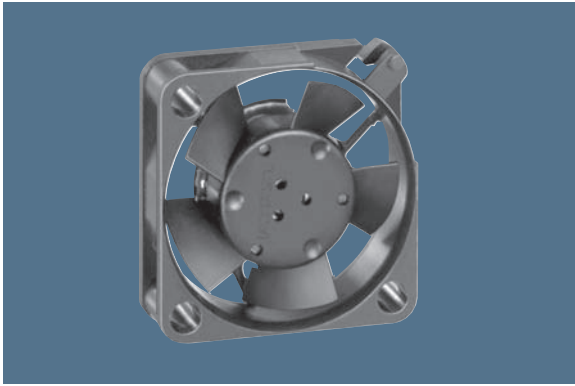

Highlights:

- Compact fan with low power consumption.

General characteristics:

- Material: fibreglass-reinforced plastic. Impeller PA, housing PBT.
- Fully integrated electronic commutation.
- Protected against reverse polarity and locking.
- Connection via single strands AWG 28, TR 64. Bared and tin-plated.
- Air exhaust over struts. Direction of rotation counter-clockwise, seen on rotor.
- Mass: 5 g.

Nominal data	Air flow		Nominal voltage	Voltage range	Sound pressure level	Sound power level	Sinter sleeve bearings Ball bearings	Power input	Nominal speed	Temperature range	Service life L ₁₀ (20 °C) ebm-papst Standard	Service life L ₁₀ (60 °C) ebm-papst Standard	Life expectancy L ₁₀ Δ (40 °C) see P. 15	Curve	Specials
	Type	m ³ /h													
255 M		2,1	1,2	5	4,5...5,5	5	< 3	□	0,2	6 000	-10...+70	45 000 / 14 000	45 000	1	
255 N		3,2	1,9	5	4,5...5,5	16	< 3	□	0,4	9 600	-10...+70	40 000 / 12 000	40 000	2	/2
255 H		4,5	2,6	5	4,5...5,5	23	4,4	□	0,6	12 000	-10...+55	35 000 / 12 000*	30 000	3	/2
252 N		3,2	1,9	12	10...14	15	< 3	□	0,5	9 000	-10...+70	40 000 / 12 000	40 000	2	/2
252 H		4,5	2,6	12	10...14	23	4,4	□	0,7	12 000	-10...+55	35 000 / 12 000*	30 000	3	

* at 55 °C

