

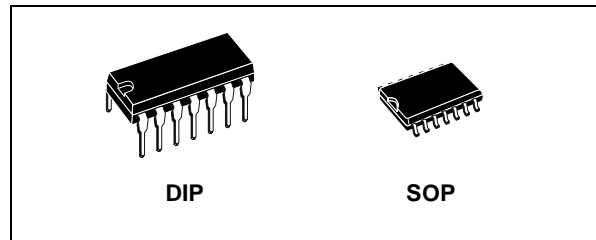

HCF4001B

QUAD 2-INPUT NOR GATE

- PROPAGATION DELAY TIME:
 $t_{PD} = 50\text{ns}$ (TYP.) at $V_{DD} = 10\text{V}$ $C_L = 50\text{pF}$
- BUFFERED INPUTS AND OUTPUTS
- STANDARDIZED SYMMETRICAL OUTPUT CHARACTERISTICS
- QUIESCENT CURRENT SPECIFIED UP TO 20V
- 5V, 10V AND 15V PARAMETRIC RATINGS
- INPUT LEAKAGE CURRENT
 $I_l = 100\text{nA}$ (MAX) AT $V_{DD} = 18\text{V}$ $T_A = 25^\circ\text{C}$
- 100% TESTED FOR QUIESCENT CURRENT



ORDER CODES

PACKAGE	TUBE	T & R
DIP	HCF4001BEY	
SOP	HCF4001BM1	HCF4001M013TR

DESCRIPTION

The HCF4001B is a monolithic integrated circuit fabricated in Metal Oxide Semiconductor technology available in DIP and SOP packages. The HCF4001B QUAD 2-INPUT NOR GATE provides the system designer with direct implementation of the NOR function and supplement the existing family of CMOS gates. All inputs and outputs are buffered.

PIN CONNECTION

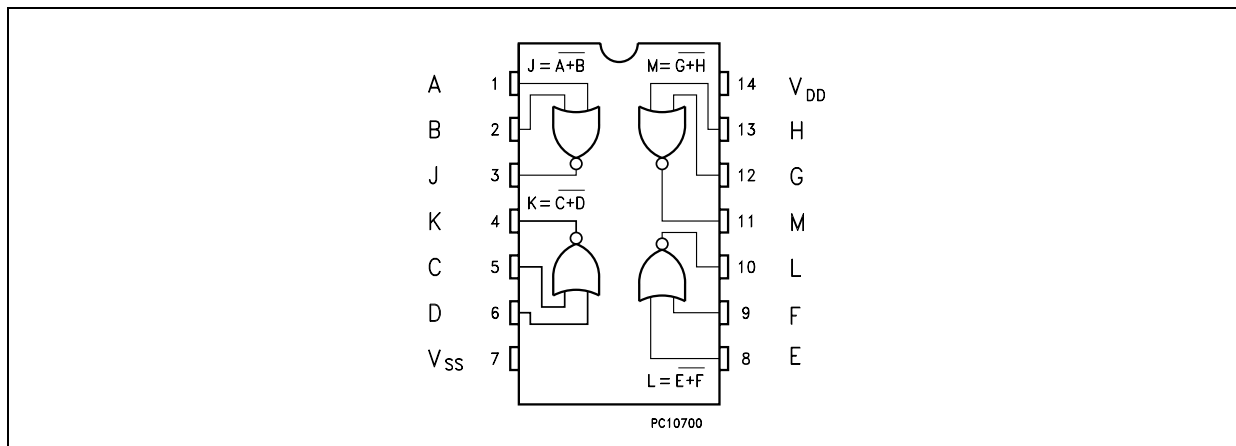

HCF4001B

INPUT EQUIVALENT CIRCUIT

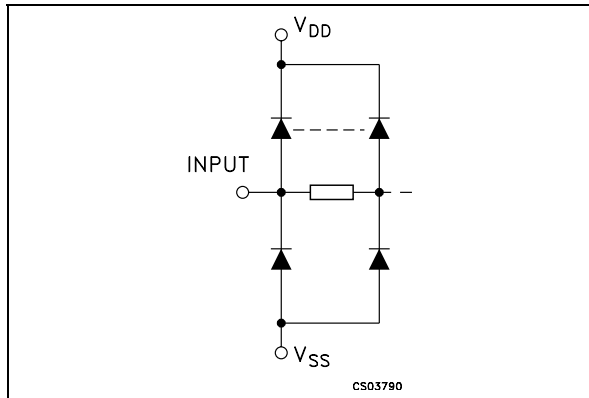

LOGIC DIAGRAM

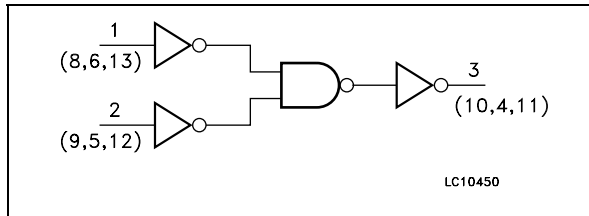

PIN DESCRIPTION

PIN N°	SYMBOL	NAME AND FUNCTION
1, 2, 5, 6, 8, 9, 12, 13	A, B, C, D, E, F, G, H	Data Inputs
3, 4, 10, 11	J, K, L, M	Data Outputs
7	V _{SS}	Negative Supply Voltage
14	V _{DD}	Positive Supply Voltage

TRUTH TABLE

INPUTS		OUTPUTS
A, C, E, G	B, D, F, H	J, K, L, M
L	L	H
L	H	L
H	L	L
H	H	L

ABSOLUTE MAXIMUM RATINGS

Symbol	Parameter	Value	Unit
V _{DD}	Supply Voltage	-0.5 to +22	V
V _I	DC Input Voltage	-0.5 to V _{DD} + 0.5	V
I _I	DC Input Current	± 10	mA
P _D	Power Dissipation per Package	200	mW
	Power Dissipation per Output Transistor	100	mW
T _{op}	Operating Temperature	-55 to +125	°C
T _{stg}	Storage Temperature	-65 to +150	°C

Absolute Maximum Ratings are those values beyond which damage to the device may occur. Functional operation under these conditions is not implied. All voltage values are referred to V_{SS} pin voltage.

RECOMMENDED OPERATING CONDITIONS

Symbol	Parameter	Value	Unit
V _{DD}	Supply Voltage	3 to 20	V
V _I	Input Voltage	0 to V _{DD}	V
T _{op}	Operating Temperature	-55 to 125	°C

DC SPECIFICATIONS

Symbol	Parameter	Test Condition				Value						Unit	
		V _I (V)	V _O (V)	I _{OL} (μ A)	V _{DD} (V)	T _A = 25°C			-40 to 85°C		-55 to 125°C		
						Min.	Typ.	Max.	Min.	Max.	Min.		Max.
I _L	Quiescent Current	0/5			5		0.01	0.25		7.5		7.5	μ A
		0/10			10		0.01	0.5		15		15	
		0/15			15		0.01	1		30		30	
		0/20			20		0.02	5		150		150	
V _{OH}	High Level Output Voltage	0/5		<1	5	4.95			4.95		4.95		V
		0/10		<1	10	9.95			9.95		9.95		
		0/15		<1	15	14.95			14.95		14.95		
V _{OL}	Low Level Output Voltage	5/0		<1	5		0.05			0.05		0.05	V
		10/0		<1	10		0.05			0.05		0.05	
		15/0		<1	15		0.05			0.05		0.05	
V _{IH}	High Level Input Voltage		0.5/4.5	<1	5	3.5			3.5		3.5		V
			1/9	<1	10	7			7		7		
			1.5/13.5	<1	15	11			11		11		
V _{IL}	Low Level Input Voltage		4.5/0.5	<1	5			1.5		1.5		1.5	V
			9/1	<1	10			3		3		3	
			13.5/1.5	<1	15			4		4		4	
I _{OH}	Output Drive Current	0/5	2.5	<1	5	-1.36	-3.2		-1.15		-1.1		mA
		0/5	4.6	<1	5	-0.44	-1		-0.36		-0.36		
		0/10	9.5	<1	10	-1.1	-2.6		-0.9		-0.9		
		0/15	13.5	<1	15	-3.0	-6.8		-2.4		-2.4		
I _{OL}	Output Sink Current	0/5	0.4	<1	5	0.44	1		0.36		0.36		mA
		0/10	0.5	<1	10	1.1	2.6		0.9		0.9		
		0/15	1.5	<1	15	3.0	6.8		2.4		2.4		
I _I	Input Leakage Current	0/18	Any Input		18		$\pm 10^{-5}$	± 0.1		± 1		± 1	μ A
C _I	Input Capacitance		Any Input				5	7.5					pF

The Noise Margin for both "1" and "0" level is: 1V min. with V_{DD}=5V, 2V min. with V_{DD}=10V, 2.5V min. with V_{DD}=15V

DYNAMIC ELECTRICAL CHARACTERISTICS (T_{amb} = 25°C, C_L = 50pF, R_L = 200K Ω , t_r = t_f = 20 ns)

Symbol	Parameter	Test Condition		Value (*)			Unit
		V _{DD} (V)		Min.	Typ.	Max.	
t _{TLH} t _{THL}	Output Transition Time	5			125	250	ns
		10			60	120	
		15			45	90	
t _{PLH} t _{PHL}	Propagation Delay Time	5			100	200	ns
		10			50	100	
		15			40	80	

(*) Typical temperature coefficient for all V_{DD} value is 0.3%/°C.

Plastic DIP-14 MECHANICAL DATA						
---------------------------------------	--	--	--	--	--	--

DIM.	mm.			inch		
	MIN.	TYP	MAX.	MIN.	TYP.	MAX.
a1	0.51			0.020		
B	1.39		1.65	0.055		0.065
b		0.5			0.020	
b1		0.25			0.010	
D			20			0.787
E		8.5			0.335	
e		2.54			0.100	
e3		15.24			0.600	
F			7.1			0.280
I			5.1			0.201
L		3.3			0.130	
Z	1.27		2.54	0.050		0.100

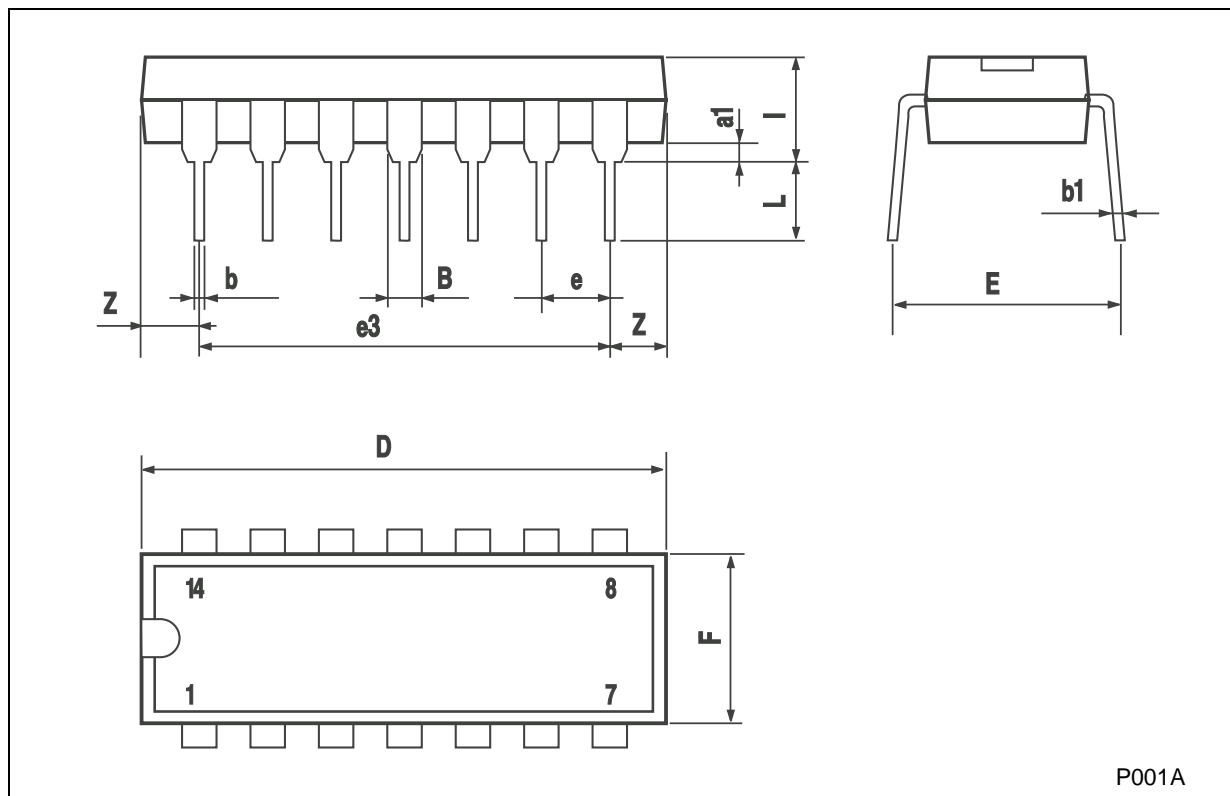

P001A