

TZV SERIES

105°C Low Impedance, Lead Free Reflow Soldering.

◆ **FEATURES**

- Load Life : 105°C 2000 hours.
- Lead free reflow soldering is available.
- Available for high density mounting.
- Low impedance at 100kHz with selected materials.
- RoHS compliance.



◆ **SPECIFICATIONS**

Items	Characteristics																																
Category Temperature Range	-55 ~ +105°C																																
Rated Voltage Range	6.3~50V.DC																																
Capacitance Tolerance	±20%(20°C,120Hz)																																
Leakage Current(MAX)	I=0.01CV or 3 μA whichever is greater. (After 2 minutes application of rated voltage) I=Leakage Current(μA) C=Rated Capacitance(μF) V=Rated Voltage(V)																																
Dissipation Factor(MAX) (tan δ)	<table border="1"> <thead> <tr> <th>Rated Voltage (V)</th> <th>6.3</th> <th>10</th> <th>16</th> <th>25</th> <th>35</th> <th>50</th> <th>(20°C,120Hz)</th> </tr> </thead> <tbody> <tr> <td>tan δ</td> <td>0.26</td> <td>0.19</td> <td>0.16</td> <td>0.14</td> <td>0.12</td> <td>0.10</td> <td></td> </tr> </tbody> </table>	Rated Voltage (V)	6.3	10	16	25	35	50	(20°C,120Hz)	tan δ	0.26	0.19	0.16	0.14	0.12	0.10																	
Rated Voltage (V)	6.3	10	16	25	35	50	(20°C,120Hz)																										
tan δ	0.26	0.19	0.16	0.14	0.12	0.10																											
Endurance	After applying rated voltage with rated ripple current for 2000 hrs at 105°C, the capacitors shall meet the following requirements. <table border="1"> <tbody> <tr> <td>Capacitance Change</td> <td>Within ±30% of the initial value.</td> </tr> <tr> <td>Dissipation Factor</td> <td>Not more than 200% of the specified value.</td> </tr> <tr> <td>Leakage Current</td> <td>Not more than the specified value.</td> </tr> </tbody> </table>	Capacitance Change	Within ±30% of the initial value.	Dissipation Factor	Not more than 200% of the specified value.	Leakage Current	Not more than the specified value.																										
Capacitance Change	Within ±30% of the initial value.																																
Dissipation Factor	Not more than 200% of the specified value.																																
Leakage Current	Not more than the specified value.																																
Low Temperature Stability Impedance Ratio(MAX)	<table border="1"> <thead> <tr> <th>Rated Voltage (V)</th> <th>6.3</th> <th>10</th> <th>16</th> <th>25</th> <th>35</th> <th>50</th> <th>(120Hz)</th> </tr> </thead> <tbody> <tr> <td>Z(-25°C)/Z(20°C)</td> <td>2</td> <td>2</td> <td>2</td> <td>2</td> <td>2</td> <td>2</td> <td></td> </tr> <tr> <td>Z(-40°C)/Z(20°C)</td> <td>3</td> <td>3</td> <td>3</td> <td>3</td> <td>3</td> <td>3</td> <td></td> </tr> <tr> <td>Z(-55°C)/Z(20°C)</td> <td>4</td> <td>4</td> <td>4</td> <td>3</td> <td>3</td> <td>3</td> <td></td> </tr> </tbody> </table>	Rated Voltage (V)	6.3	10	16	25	35	50	(120Hz)	Z(-25°C)/Z(20°C)	2	2	2	2	2	2		Z(-40°C)/Z(20°C)	3	3	3	3	3	3		Z(-55°C)/Z(20°C)	4	4	4	3	3	3	
Rated Voltage (V)	6.3	10	16	25	35	50	(120Hz)																										
Z(-25°C)/Z(20°C)	2	2	2	2	2	2																											
Z(-40°C)/Z(20°C)	3	3	3	3	3	3																											
Z(-55°C)/Z(20°C)	4	4	4	3	3	3																											

◆ **MULTIPLIER FOR RIPPLE CURRENT**

Frequency coefficient

Frequency (Hz)		120	1k	10k	100k ≤
Coefficient	4.7 μF	0.42	0.60	0.80	1.00
	10 ~ 33 μF	0.45	0.75	0.90	1.00
	47 ~ 100 μF	0.50	0.80	0.95	1.00
	220 ~ 1000 μF	0.60	0.85	0.95	1.00

◆ **MARKING**

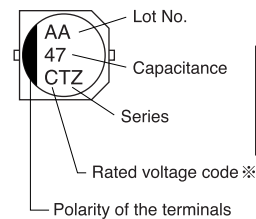

※ Voltage Code

Rated Voltage (V)	6.3	10	16	25	35	50
Rated Voltage code	j	A	C	E	V	H

◆ **PART NUMBER**

□□□ TZV □□□□□ □ □□□ D X L
 Rated Voltage Series Rated Capacitance Capacitance Tolerance Option Case Size

◆ DIMENSIONS

(mm)

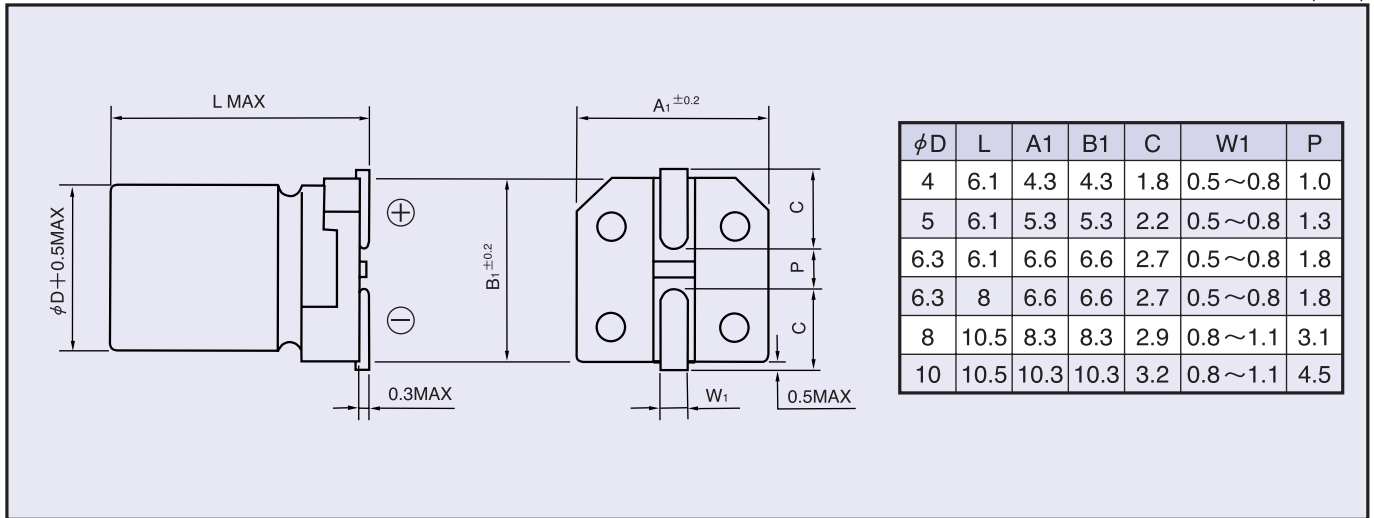

◆ STANDARD SIZE

Size $\phi D \times L$ (mm), Ripple Current (mA r.m.s./105°C, 100kHz), Impedance(Ω MAX/20°C, 100kHz)

Cap(μF) \ WV (V.DC)	6.3 (0J)			10 (1A)			16 (1C)		
	Size	Ripple	Z	Size	Ripple	Z	Size	Ripple	Z
10							4×6.1	90	1.35
22	4×6.1	90	1.35				4×6.1	90	1.35
							5×6.1	170	0.70
33	4×6.1	90	1.35	4×6.1	90	1.35	5×6.1	170	0.70
							5×6.1	170	0.70
47	4×6.1	90	1.35	6.3×8	300	0.34	5×6.1	170	0.70
	5×6.1	170	0.70				6.3×6.1	250	0.36
100	5×6.1	170	0.70	6.3×8	300	0.34	6.3×6.1	250	0.36
	6.3×6.1	250	0.36				6.3×8	300	0.34
220	6.3×6.1	250	0.36	8×10.5	600	0.16	6.3×8	300	0.34
	6.3×8	300	0.34				8×10.5	600	0.16
330	6.3×8	300	0.34	8×10.5	600	0.16	10×10.5	850	0.08
470				10×10.5	850	0.08			
680									
1000	8×10.5	600	0.16						

Cap(μF) \ WV (V.DC)	25 (1E)			35 (1V)			50 (1V)		
	Size	Ripple	Z	Size	Ripple	Z	Size	Ripple	Z
4.7				4×6.1	90	1.45	4×6.1	60	2.90
10				4×6.1	90	1.45	5×6.1	85	1.52
				5×6.1	170	0.70	6.3×6.1	165	0.88
22				5×6.1	170	0.70	6.3×6.1	165	0.88
				6.3×6.1	250	0.36			
33	5×6.1	170	0.70	6.3×6.1	250	0.36	6.3×8	195	0.68
	6.3×6.1	250	0.36						
47	6.3×6.1	250	0.36	6.3×6.1	250	0.36	6.3×8	195	0.68
				6.3×8	300	0.34			
100	6.3×8	300	0.34	6.3×8	300	0.34	8×10.5	350	0.34
				8×10.5	600	0.16			
220	8×10.5	600	0.16	8×10.5	600	0.16	10×10.5	670	0.18
330	8×10.5	600	0.16	10×10.5	850	0.09			
470	10×10.5	850	0.09						