

SD

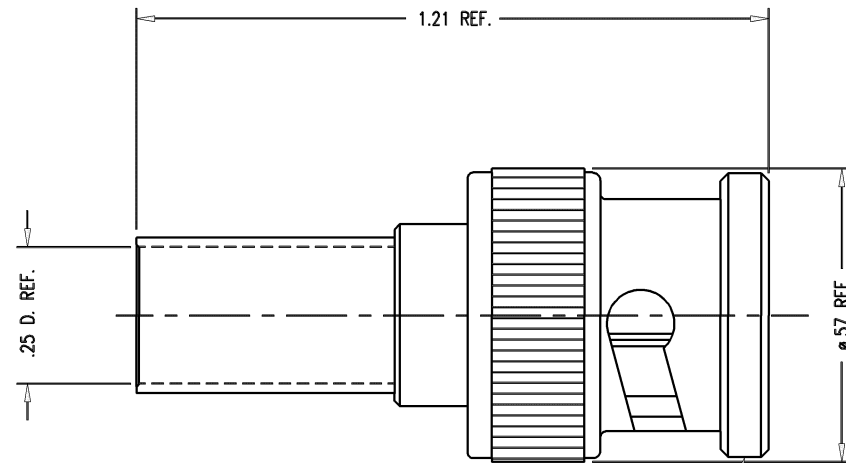

STAMP: KINGS P/N 2065-7-9
YR WK (DATE CODE)

NOTES:

1. FOR USE WITH BELDEN 8241, RG 59, & 210/U CABLE.
2. FOR CABLING INSTRUCTIONS SEE 3-661-1.
3. FOR CRIMPING USE DIE KTH-2261.
4. INTERFACE PER KINGS ES-17, FIG. 6.
5. MATERIALS:
 - INSULATOR-TEFLON, ASTM-D-4894
 - GASKET-SILICONE RUBBER, ZZ-R-765
 - SPRING WASHER } BER. COP., ASTM-B-196
 - OUTER CONTACT }
 - K-GRIP SLEEVE-COMMERCIAL BRONZE, ASTM-B-135
 - ALL OTHER METAL PARTS-BRASS, ASTM-B16
6. FINISHES:
 - CENTER CONTACTS-GOLD PLATE PER MIL-G-45204
 - SPRING WASHER-SILVER PLATE PER QQ-S-365
 - ALL OTHER METAL PARTS-KINGS TARNISH RESISTANT NICKEL FINISH (TR-5)
7. ELECTRICAL CHARACTERISTICS:
 - NOMINAL IMPEDANCE-75 OHMS
 - WORKING VOLTAGE-500 VRMS
 - FREQUENCY RANGE-DC TO 3 GHZ

SD

REVISIONS

ISSUE	CHANGES
0	ER 37767 DCT 01/11/99
1	CN 37782 E DCT 01/29/99
2	CN 37804 E TML 04/01/99
3	CN 37837 C TML 05/20/99
4	CN 37862 A GEH 07/06/99
5	CN 37933 D TML 11/09/99
6	CN 38011 D HVN 05/23/00

2065-7-9

206579S

SCALE 4:1

APPROX SURFACE AREA

USED ON

REF:

PL, 75 BNC

DRAWN TML DATE 01/11/99

DESIGN DCT DATE 01/11/99

APPR. DATE

KINGS
ELECTRONICS CO., INC.
ROCK HILL, SC 29730

2065-7-9