

## 2-5329445-1 Product Details

[Share](#) [Print](#) [Email](#)



2-5329445-1

TE Internal Number: 2-5329445-1

 Active

[View 3D PDF](#)

### BNC RF Connectors

 Always EU RoHS/ELV Compliant  
(Statement of Compliance)

### Product Highlights:

- Connector - RF
- Plug
- Connector Style = Plug
- Applies To Coaxial Cable
- Coaxial Cable Termination Type = Crimp

[View all Features](#)

### Quick Links

- ▶ [Pricing & Availability](#)
- ▶ [Search for Tooling](#)
- ▶ [Product Feature Selector](#)
- ▶ [Contact Us About This Product](#)

[Add to My Part List](#)

[Request Sample](#)

[Find Similar Products](#)

[Buy Product](#)

### Documentation & Additional Information

#### Product Drawings:

- [PLUG, BNC](#) (PDF, English)

#### Catalog Pages/Data Sheets:

- [BNC Connectors](#) (PDF, English)

#### Product Specifications:

- None Available

#### Application Specifications:

- None Available

#### Instruction Sheets:

- None Available

#### CAD Files: (CAD Format & Compression Information)

- [2D Drawing](#) (DXF, Version A)
- [3D Model](#) (IGES, Version A)
- [3D Model](#) (STEP, Version A)

[List all Documents](#)

#### Related Products:

- [Tooling](#)

### Product Features (Please use the Product Drawing for all design activity)

#### Product Type Features:

- [Product Type](#) = Connector - RF
- [Gender](#) = Plug
- [Grade](#) = Military
- [Sealed](#) = No
- [Isolated](#) = No
- [Dielectric Material](#) = Fluoropolymer
- [Coupling Nut Material](#) = Brass

#### Mechanical Attachment:

- [Surface Mountable](#) = No
- [Hardware Included](#) = No
- [Panel Mount Retention](#) = Without

#### Electrical Characteristics:

- [Connector Impedance](#) ( $\Omega$ ) = 50

#### Termination Features:

#### Contact Features:

- [Center Contact Material](#) = Brass
- [Center Contact Plating](#) = Gold

#### Housing Features:

- [Connector Style](#) = Plug

#### Configuration Features:

- [Coaxial Cable Type \(RG/U or Mfg.\)](#) = 124, 140, 210, 59, 59A, 59B, 62, 62A, 62B
- [Number of Ports](#) = 1
- [Solder Terminal](#) = Without

#### Industry Standards:

- [Government/Industry Qualification](#) = No
- [RoHS/ELV Compliance](#) = RoHS compliant, ELV compliant
- [Lead Free Solder Processes](#) = Not relevant for lead free process

- [Coaxial Cable Termination Type](#) = Crimp
- [Crimp Type](#) = Single

**Body Features:**

- [Body Style](#) = Straight
- [Body Plating](#) = Silver
- [Body Insulation](#) = Without
- [Polarized](#) = No

- [RoHS/ELV Compliance History](#) = Always was RoHS compliant

**Conditions for Usage:**

- [Applies To](#) = Coaxial Cable

**Other:**

- [Brand](#) = TE Connectivity

**Corporate Information**

- [About TE](#)
- [Investors](#)
- [News Room](#)
- [Supplier Portal](#)
- [Careers](#)
- [Terms & Conditions](#)
- [Privacy Policy](#)

**Quick Links**

- [Distributor Inventory](#)
- [Product Cross Reference](#)
- [Documents & Drawings](#)
- [Product Compliance Support Center](#)
- [Site Map](#)

**Customer Support**

- [Email or Chat With Us](#)
- [Find a Phone Number](#)
- [Knowledge Base](#)
- [Manage Your Account](#)

**Keep Me Informed**



THIS DRAWING IS UNPUBLISHED. RELEASED FOR PUBLICATION  
 © COPYRIGHT BY TYCO ELECTRONICS CORPORATION. ALL RIGHTS RESERVED.

| LOC | DIST | REVISIONS   |                       |         |       |
|-----|------|-------------|-----------------------|---------|-------|
| P   | LTR  | DESCRIPTION | DATE                  | DWN     | APVD  |
| AJ  | 16   | A           | REV PER ECO 06-002539 | 06APR06 | GB JH |

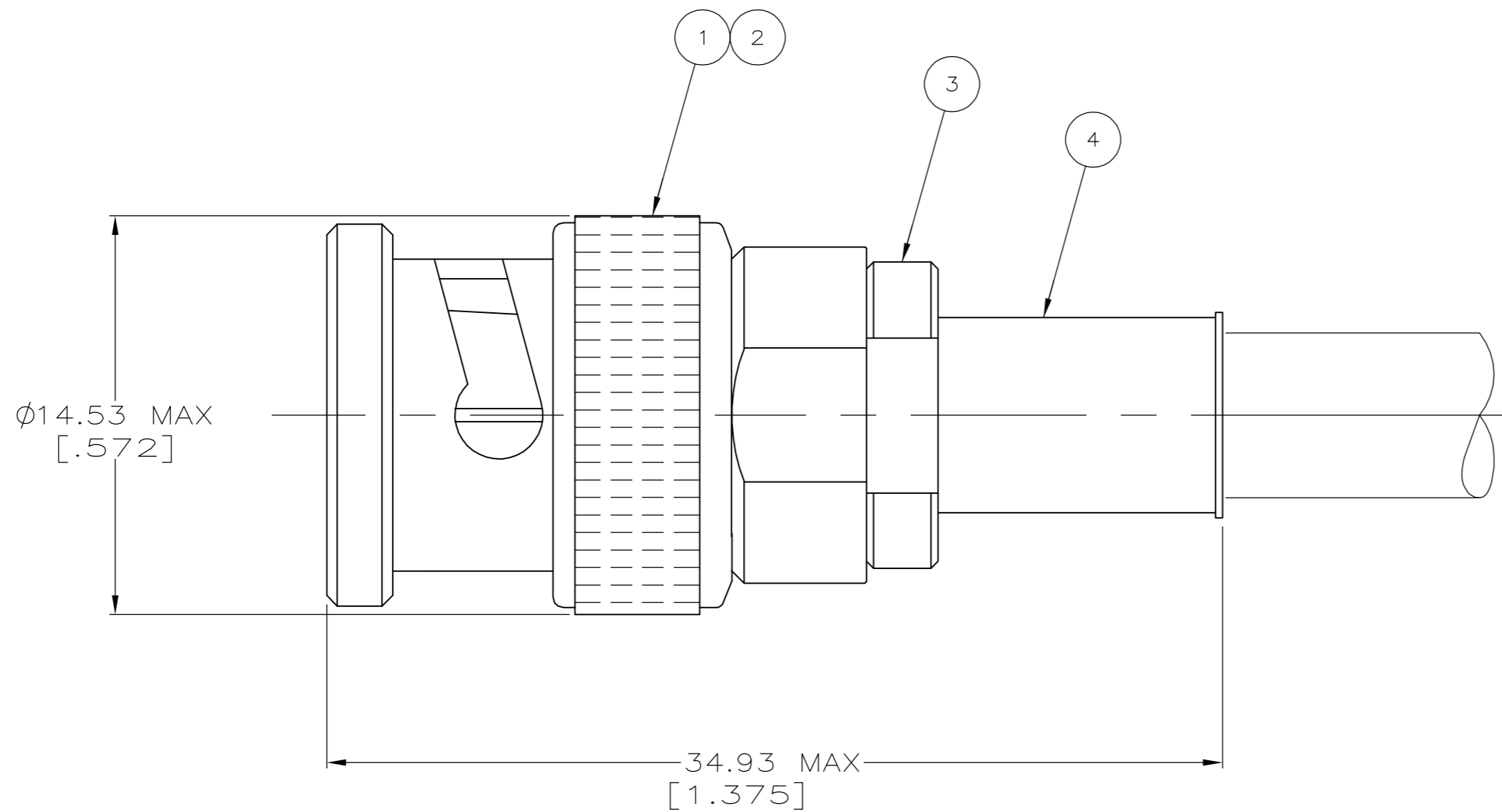

- 1. FOR CABLE: RG-59/U, 59A/U, 59B/U, 62/U, 62A/U, 62B/U, 124/U, 140/U, 210/U
- 2. USE INSTRUCTION SHEET 408-1799-1

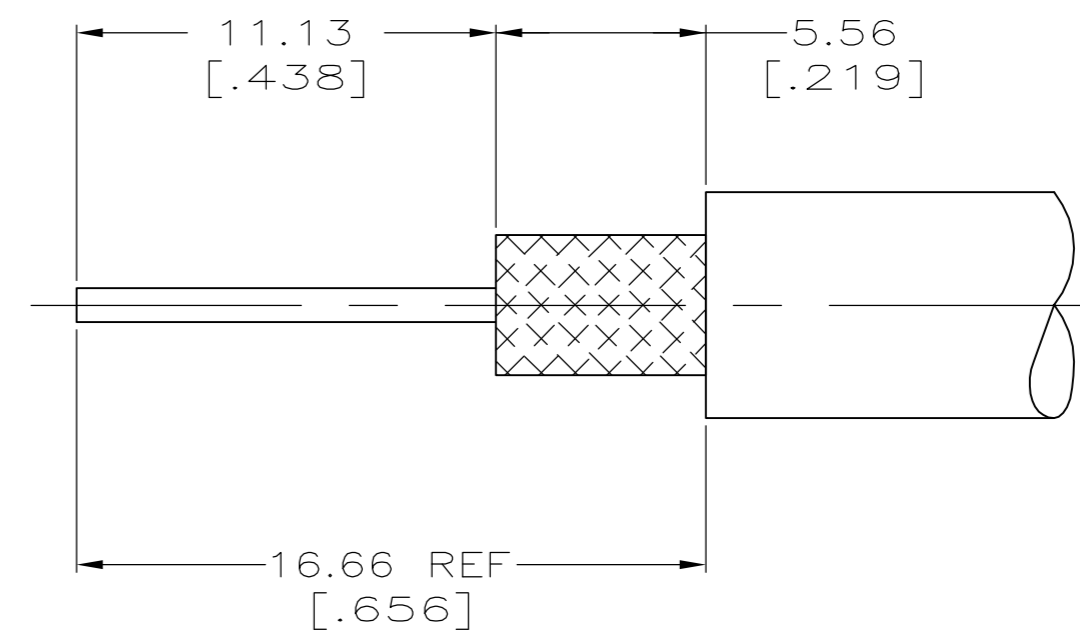

RECOMMENDED STRIP LENGTH  
NO SCALE

|       |            |                    |                                  |                   |                          |                |
|-------|------------|--------------------|----------------------------------|-------------------|--------------------------|----------------|
| 1     | 69141-1    | 9-329041-0         | 9-50780-1                        | 2-329106-1        | 9-329804-0               | 2-5329445-1    |
| CABLE | CRIMP TOOL | 4 FERRULE<br>QTY=1 | 3 CRIMP END<br>ASSEMBLY<br>QTY=1 | 2 GASKET<br>QTY=1 | 1 PLUG ASSEMBLY<br>QTY=1 | PART<br>NUMBER |

THIS DRAWING IS A CONTROLLED DOCUMENT.

|                       |   |                                 |   |
|-----------------------|---|---------------------------------|---|
| DIMENSIONS:<br>INCHES | TOLERANCES UNLESS<br>OTHERWISE SPECIFIED: | DWN<br>J. HAVENER<br>16SEP2005  | Tyco Electronics Corporation<br>Harrisburg, PA 17105-3608 |
|                       | 0 PLC ± -                                 | CHK<br>J. HAVENER<br>16SEP2005  |   |
|                       | 1 PLC ± -                                 | APVD<br>J. LIPPERT<br>16SEP2005 |   |
|                       | 2 PLC ± 0.41 [.016]                       | PRODUCT SPEC                    |   |
| MATERIAL              | FINISH                                    | APPLICATION SPEC                | NAME<br>PLUG, BNC   |
|                       |   | WEIGHT                          | SIZE<br>A2  |
|                       |   | CUSTOMER DRAWING                | CAGE CODE<br>00779  |
|                       |   |                                 | DRAWING NO<br>5329445                                     |
|                       |   |                                 | RESTRICTED TO   |
|                       |   |                                 | SCALE<br>5:1  |
|                       |   |                                 | SHEET<br>1 of 1   |
|                       |   |                                 | REV<br>A  |

329445

5329445