

1825108-2 Product Details

[Share](#) [Print](#) [Email](#)

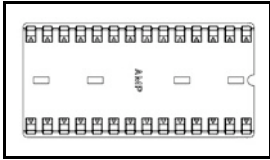

1825108-2

TE Internal Number:
1825108-2

 Active

DIP Sockets

 Always EU RoHS/ELV Compliant (Statement of Compliance)

Product Highlights:

- Socket Style = Standard
- Through Hole Contact Termination Type
- 2.54 mm Centerline
- Row-to-Row Spacing = 15.49 mm
- 28 Positions

[View all Features](#)

Quick Links

- ▶ [Pricing & Availability](#)
- ▶ [Search for Tooling](#)
- ▶ [Product Feature Selector](#)
- ▶ [Contact Us About This Product](#)

[Add to My Part List](#)

[Request Sample](#)

[Find Similar Products](#)

[Buy Product](#)

Documentation & Additional Information

Product Drawings:

- None Available

Catalog Pages/Data Sheets:

- None Available

Product Specifications:

- None Available

Application Specifications:

- [DIPLOMATE Dual Leaf \(DL\) Low-Profile DIP Sockets \(PDF, English\)](#)

Instruction Sheets:

- None Available

CAD Files:

- None Available

Additional Information:

- [Product Line Information](#)

Related Products:

- [Tooling](#)

[List all Documents](#)

Product Features (Please use the Product Drawing for all design activity)

Product Type Features:

- Profile = Standard
- [Frame Style](#) = Closed
- [Leg Style](#) = Straight
- Color = Black

Electrical Characteristics:

- Insulation Resistance (MΩ) = 10,000
- Contact Resistance (mΩ) = 30

Termination Features:

- [Contact Termination Type](#) = Through Hole
- [Termination Post Length \(mm \[in\]\)](#) = 3.25 [0.128]

Dimensions:

- [Height Above PC Board \(mm \[in\]\)](#) = 5.33 [0.210]

Body Features:

- [Row-to-Row Spacing \(mm \[in\]\)](#) = 15.49 [0.610]
- [Mount Style](#) = Vertical

Housing Features:

- [Centerline \(mm \[in\]\)](#) = 2.54 [0.100]
- Housing Material = Thermoplastic - GF
- UL Flammability Rating = UL 94V-0

Configuration Features:

- [Number of Positions](#) = 28

Industry Standards:

- [RoHS/ELV Compliance](#) = RoHS compliant, ELV compliant
- [Lead Free Solder Processes](#) = Wave solder capable to 240°C, Wave solder capable to 260°C, Wave solder capable to 265°C
- RoHS/ELV Compliance History = Always was RoHS compliant

Conditions for Usage:

- Temperature Range (°C) = 125

Operation/Application:

Contact Features:

- [Socket Style](#) = Standard
- [Contact Base Material](#) = Phosphor Bronze
- [Contact Plating, Mating Area, Material](#) = Gold (15)
- [Contact Style](#) = Stamped + Formed
- [Mating Contact Type](#) = Dual Leaf
- [Solder Tail Contact Plating](#) = Tin

- [Application](#) = Production

Packaging Features:

- [Packaging Method](#) = Tube

Other:

- [Brand](#) = TE Connectivity
- [Proprietary Name](#) = DIPLOMATE DL
- [Comment](#) = ONLY sockets with straight solder tails are recommended for automatic insertion.

Corporate Information

- [About TE](#)
- [Investors](#)
- [News Room](#)
- [Supplier Portal](#)
- [Careers](#)
- [Terms & Conditions](#)
- [Privacy Policy](#)

Quick Links

- [Distributor Inventory](#)
- [Product Cross Reference](#)
- [Documents & Drawings](#)
- [Product Compliance Support Center](#)
- [Site Map](#)

Customer Support

- [Email or Chat With Us](#)
- [Find a Phone Number](#)
- [Knowledge Base](#)
- [Manage Your Account](#)

Keep Me Informed

NOTE

All numerical values are in metric units [with U.S. customary units in brackets]. Dimensions are in millimeters [and inches]. Unless otherwise specified, dimensions have a tolerance of ± 0.13 [± 0.005] and angles have a tolerance of $\pm 2^\circ$. Figures and illustrations are for identification only and are not drawn to scale.

1. INTRODUCTION

This specification covers the requirements for application of DIPLOMATE DL low-profile DIP sockets. The socket consists of a housing and solder contacts. The housing features a polarization indicator, which indicates circuit cavity No. 1. The socket is available in 6 through 64 positions. The sockets are designed for manual or automatic application to a printed circuit (pc) board.

When corresponding with personnel, use the terminology provided in this specification to facilitate your inquiries for information. Basic terms and features of this product are provided in Figure 1.

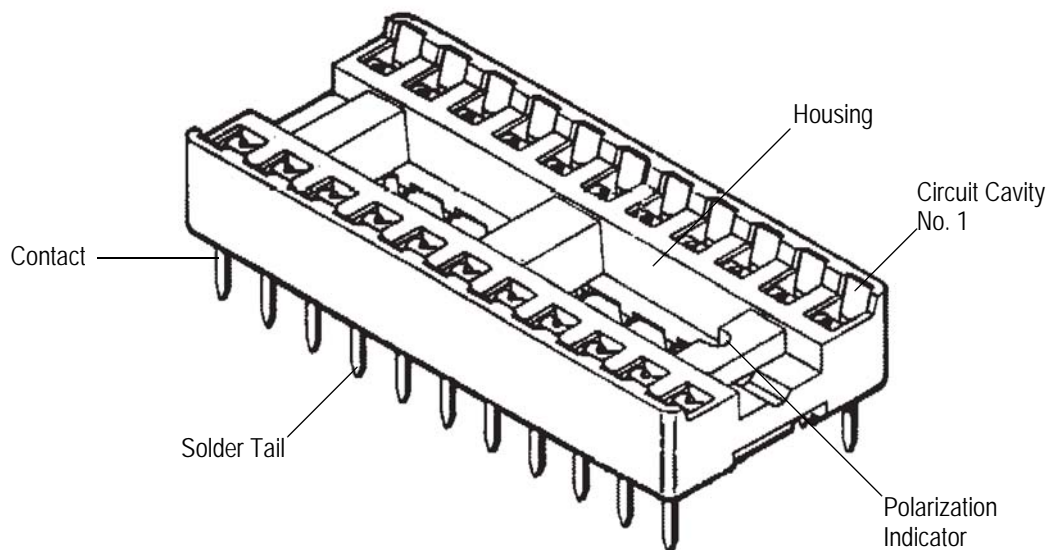

Figure 1

2. REFERENCE MATERIAL

2.1. Revision Summary

Changed to this application specification include:

- Changed company name and logo
- Updated application specification to corporate requirements
- Replaced part number and product code in Paragraph 2.2

2.2. Customer Assistance

Reference Product Base Part Number 382568 and Product Code 1541 are representative of DIPLOMATE DL low-profile DIP sockets. Use of these numbers will identify the product line and expedite your inquiries through a service network established to help you obtain product and tooling information. Such information can be obtained through a local Representative or, after purchase, by calling PRODUCT INFORMATION at the number at the bottom of this page.

2.3. Drawings

Customer Drawings for product part numbers are available from the service network. If there is a conflict between the information contained in the Customer Drawings and this specification or with any other technical documentation supplied, the information contained in the Customer Drawings takes priority.

2.4. Specifications

Product Specification 108-1066 provides product performance and test information.

2.5. Instructional Material

Instruction Sheets (408-series) provide product assembly instructions or tooling setup and operation procedures and Customer Manuals (409-series) provide machine setup and operating procedures. There are no documents available that pertain to this product.

2.6. Manuals

Manual 402-40 can be used as a guide to soldering. This manual provides information on various flux types and characteristics with the commercial designation and flux removal procedures. A checklist is included in the manual as a guide for information on soldering problems.

3. REQUIREMENTS

3.1. Storage

A. Ultraviolet Light

Prolonged exposure to ultraviolet light may deteriorate the chemical composition used in the socket material.

B. Shelf Life

The sockets should remain in the shipping containers until ready for use to prevent deformation to the contacts. The sockets should be used on a first in, first out basis to avoid storage contamination that could adversely affect performance.

3.2. PC Board

A. Thickness

The recommended maximum pc board thickness is 2.36 [.093].

B. Layout

The pc board layout must be designed using the dimensions given in Figure 2.

3.3. Soldering

A. Process

Manual 402-40 provides guidelines for soldering process.

B. Flux Selection

Contact solder tines must be fluxed prior to soldering with a mildly active, rosin base flux. Selection of the flux will depend on the type of pc board and other components mounted on the board. Additionally, the flux must be compatible with the wave solder line, manufacturing, health, and safety requirements.

C. Cleaning

After soldering, removal of fluxes, residues, and activators is necessary. Consult with the supplier of the solder and flux for recommended cleaning solvents.

D. Drying

When drying cleaned assemblies and pc boards, the temperature limitation must not be exceeded: 105°C [221°F] and 85°C [185°F] for copper alloy contact material. Excessive temperatures may cause housing degradation and/or plating deterioration.

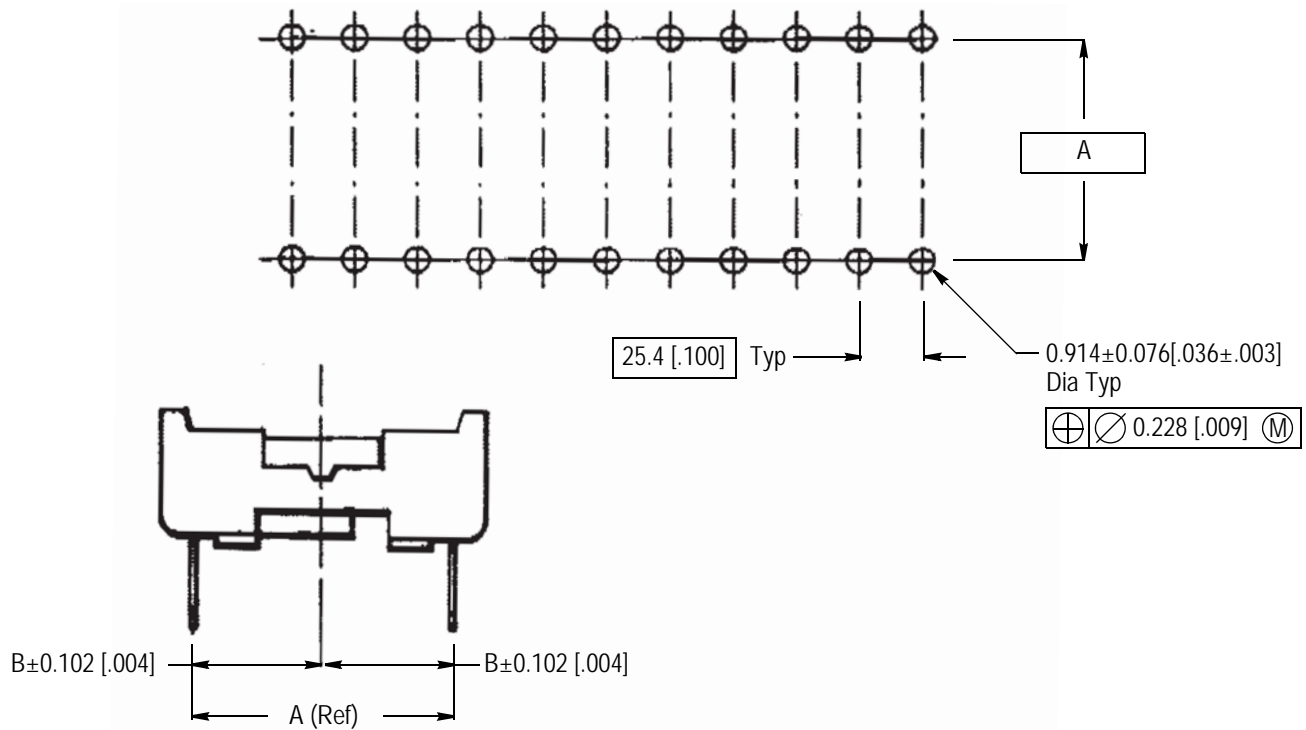

SOCKET NUMBER OF POSITIONS	CENTERLINE SPACING DIMENSION	
	A	B
6-20	76.2 [.300]	3.81 [.150]
22	10.16 [.400]	5.08 [.200]
24-48	15.24 [.600]	7.62 [.300]
64	22.85 [.900]	—

Figure 2

3.4. Seating the Socket

To hold the socket in place during handling and soldering, solder tail clinching may be desired. Method of clinching is at the discretion of the application.

NOTE

Sockets with a retention leg do not need clinching to hold them in place.



Excessive force to the ends of the solder tails (perpendicular to the pc board) must be avoided; otherwise the contacts could become dislodged from their position in the housing.

3.5. Checking Installed Socket

The socket must be parallel to the pc board and the housing must be bottomed on the pc board. Solder fillets must be evenly formed around each contact solder tine. There must be no cracks in the solder.

4. QUALIFICATION

DIPLOMATE DL low-profile DIP sockets are Recognized by Underwriters Laboratories Inc. (UL) and Certified by CSA International.

5. TOOLING

These sockets can be applied to the pc board manually or by automatic machine. For recommended machines, call TOOLING ASSISTANCE CENTER at the number at the bottom of page 1.

6. VISUAL AID

The illustration below shows a typical application of this product. This illustration should be used by production personnel to ensure a correctly applied product. Applications which DO NOT appear correct should be inspected using the information in the preceding pages of this specification and in the instructional material shipped with the product or tooling.

HOUSING MUST BE BOTTOMED
ON PC BOARD

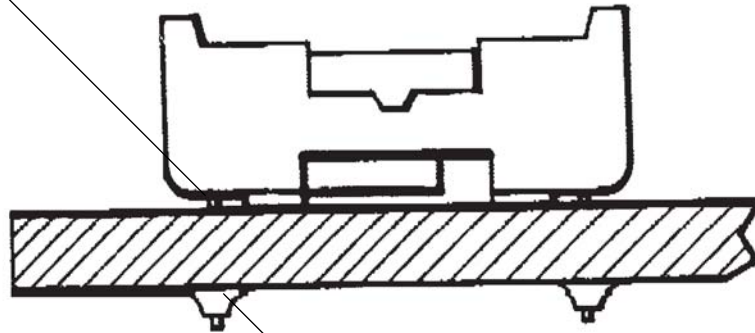

ALL SOLDER FILLETS MUST BE EVENLY FORMED
AROUND EACH CONTACT SOLDER TAIL AND
THERE MUST BE NO CRACKS IN SOLDER

FIGURE 3. VISUAL AID