

ADM803/ADM809/ADM810

FEATURES

- Specified over temperature
- Low power consumption (17 μ A)
- Precision voltage monitor: 2.5 V, 3 V, 3.3 V, 5 V options
- Reset assertion down to 1 V V_{CC}
- 140 ms minimum power-on reset
 - Open-drain $\overline{\text{RESET}}$ output (ADM803)
 - Push-pull $\overline{\text{RESET}}$ output (ADM809)
 - Push-pull RESET output (ADM810)
- SC70 and SOT-23 packages

APPLICATIONS

- Microprocessor systems
- Computers
- Controllers
- Intelligent instruments
- Automotive systems

FUNCTIONAL BLOCK DIAGRAM

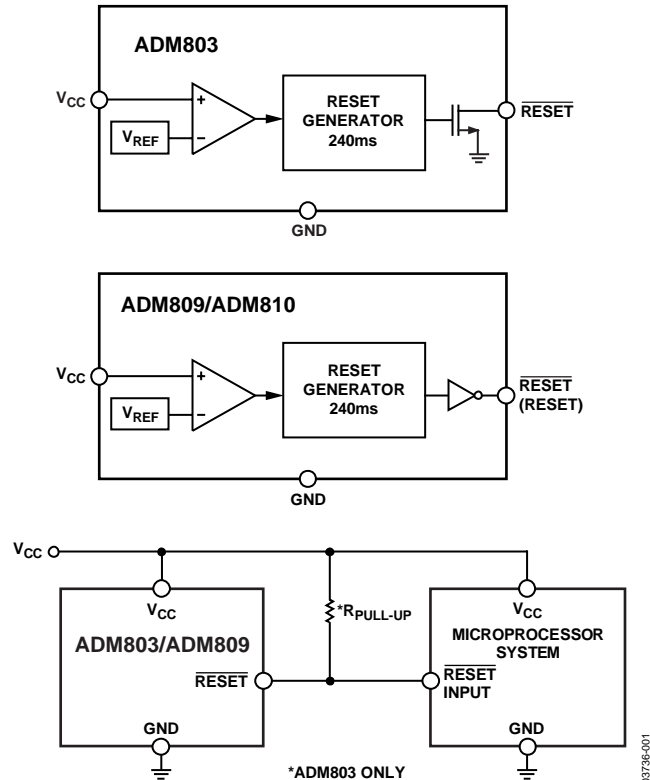

Figure 1.

GENERAL DESCRIPTION

The ADM803/ADM809/ADM810 supervisory circuits monitor the power supply voltage in microprocessor systems. They provide a reset output during power-up, power-down, and brownout conditions. On power-up, an internal timer holds reset asserted for 240 ms. This holds the microprocessor in a reset state until conditions have stabilized. The $\overline{\text{RESET}}$ output remains operational with V_{CC} as low as 1 V. The ADM803 and ADM809 provide an active low reset signal ($\overline{\text{RESET}}$), while the ADM810 provides an active high signal (RESET) output. The ADM809 and ADM810 have push-pull outputs, whereas the ADM803 has an open-drain output, which requires an external pull-up resistor.

Seven reset threshold voltage options are available, suitable for monitoring a variety of supply voltages (see Table 2).

The reset comparator features built-in glitch immunity, making it immune to fast transients on V_{CC} .

The ADM803/ADM809/ADM810 consume only 17 μ A, making them suitable for low power, portable equipment. The ADM803 is available in a 3-lead SC70; the ADM809/ADM810 are available in 3-lead SOT-23 and SC70 packages.

Rev. G

Information furnished by Analog Devices is believed to be accurate and reliable. However, no responsibility is assumed by Analog Devices for its use, nor for any infringements of patents or other rights of third parties that may result from its use. Specifications subject to change without notice. No license is granted by implication or otherwise under any patent or patent rights of Analog Devices. Trademarks and registered trademarks are the property of their respective owners.

TABLE OF CONTENTS

Features	1	Pin Configuration and Function Descriptions.....	5
Applications.....	1	Typical Performance Characteristics	6
Functional Block Diagram	1	Interfacing to Other Devices' Output	8
General Description	1	Ensuring a Valid Reset Output Down to $V_{CC} = 0\text{ V}$	8
Revision History	2	Benefits of an Accurate Reset Threshold	8
Specifications.....	3	Interfacing to Microprocessors with Multiple Interrupts.....	8
Absolute Maximum Ratings.....	4	Outline Dimensions	9
ESD Caution.....	4	Ordering Guide	9

REVISION HISTORY

9/06—Rev. F to Rev. G

Updated Outline Dimensions	9
Changes to Ordering Guide	9

6/05—Rev. E to Rev. F.

Changes to Ordering Guide	4
Updated Outline Dimensions	9

2/05—Rev. D to Rev. E.

Changes to Ordering Guide	4
---------------------------------	---

2/05—Rev. C to Rev. D.

Changes to Ordering Guide	4
Updated Outline Dimensions	8

5/03—Rev. B to Rev. C.

Added ADM803.....	Universal
Changes to Features.....	1
Changes to General Description	1
Changes to Figure 1	1
Changes to Specifications	2
Changes to Table I	3
Updated Ordering Guide.....	4

1/03—Rev. A to Rev. B.

Changes to Specifications.....	2
Changes to Table I	3
Changes to Ordering Guide	4
Changes to TPCs 1–3, and TPC 7	5
Updated Outline Dimensions	7

10/02—Rev. 0 to Rev. A.

Addition of SC70 package	Universal
Change to General Description	1
Changes to Specifications.....	2
Changes to Absolute Maximum Ratings.....	3
Change to Table I.....	3
Change to Ordering Guide.....	4
Change to TPC 1	5
Updated Outline Dimensions	7

SPECIFICATIONS

V_{CC} = full operating range, $T_A = T_{MIN}$ to T_{MAX} , V_{CC} Typ = 5 V for L/M/J models, 3.3 V for T/S models, 3 V for R models, 2.5 V for Z models, unless otherwise noted.

Parameter	Min	Typ	Max	Unit	Test Conditions/Comments
V_{CC} OPERATING VOLTAGE RANGE	1.0		5.5	V	$T_A = 0^\circ\text{C}$ to 70°C
	1.2		5.5	V	$T_A = -40^\circ\text{C}$ to $+125^\circ\text{C}$
		24	35	μA	$V_{CC} < 5.5$ V, ADM8_L/M/J, $T_A = -40^\circ\text{C}$ to $+85^\circ\text{C}$
		17	30	μA	$V_{CC} < 3.6$ V, ADM8_R/S/T/Z, $T_A = -40^\circ\text{C}$ to $+85^\circ\text{C}$
Supply Current			60	μA	$V_{CC} < 5.5$ V, ADM8_L/M/J, $T_A = 85^\circ\text{C}$ to 125°C
			60	μA	$V_{CC} < 3.6$ V, ADM8_R/S/T/Z, $T_A = 85^\circ\text{C}$ to 125°C
	RESET VOLTAGE THRESHOLD				
	ADM8_L	4.56	4.63	4.70	V
ADM8_L	4.50		4.75	V	$T_A = -40^\circ\text{C}$ to $+85^\circ\text{C}$
ADM8_L	4.44		4.82	V	$T_A = -40^\circ\text{C}$ to $+125^\circ\text{C}$
ADM8_M	4.31	4.38	4.45	V	$T_A = 25^\circ\text{C}$
ADM8_M	4.25		4.50	V	$T_A = -40^\circ\text{C}$ to $+85^\circ\text{C}$
ADM8_M	4.20		4.56	V	$T_A = -40^\circ\text{C}$ to $+125^\circ\text{C}$
ADM8_J	3.93	4.00	4.06	V	$T_A = 25^\circ\text{C}$ (ADM809/ADM810 only)
ADM8_J	3.89		4.10	V	$T_A = -40^\circ\text{C}$ to $+85^\circ\text{C}$ (ADM809/ADM810 only)
ADM8_J	3.80		4.20	V	$T_A = -40^\circ\text{C}$ to $+125^\circ\text{C}$ (ADM809/ADM810 only)
ADM8_T	3.04	3.08	3.11	V	$T_A = 25^\circ\text{C}$
ADM8_T	3.00		3.15	V	$T_A = -40^\circ\text{C}$ to $+85^\circ\text{C}$
ADM8_T	2.95		3.21	V	$T_A = -40^\circ\text{C}$ to $+125^\circ\text{C}$
ADM8_S	2.89	2.93	2.96	V	$T_A = 25^\circ\text{C}$
ADM8_S	2.85		3.00	V	$T_A = -40^\circ\text{C}$ to $+85^\circ\text{C}$
ADM8_S	2.81		3.05	V	$T_A = -40^\circ\text{C}$ to $+125^\circ\text{C}$
ADM8_R	2.59	2.63	2.66	V	$T_A = 25^\circ\text{C}$
ADM8_R	2.55		2.70	V	$T_A = -40^\circ\text{C}$ to $+85^\circ\text{C}$
ADM8_R	2.52		2.74	V	$T_A = -40^\circ\text{C}$ to $+125^\circ\text{C}$
ADM8_Z	2.28	2.32	2.35	V	$T_A = 25^\circ\text{C}$
ADM8_Z	2.25		2.38	V	$T_A = -40^\circ\text{C}$ to $+85^\circ\text{C}$
ADM8_Z	2.22		2.42	V	$T_A = -40^\circ\text{C}$ to $+125^\circ\text{C}$
RESET THRESHOLD TEMPERATURE COEFFICIENT		30		ppm/ $^\circ\text{C}$	
V_{CC} to Reset Delay		20		μs	$V_{CC} = V_{TH}$ to $(V_{TH} - 100$ mV)
RESET ACTIVE TIMEOUT PERIOD	140	240	460	ms	$T_A = -40^\circ\text{C}$ to $+85^\circ\text{C}$
	100		840	ms	$T_A = 85^\circ\text{C}$ to 125°C
RESET OUTPUT VOLTAGE LOW (ADM803/ADM809)			0.3	V	$V_{CC} = V_{TH}$ min, $I_{SINK} = 1.2$ mA, ADM803R/S/T/Z, ADM809R/S/T/Z
			0.4	V	$V_{CC} = V_{TH}$ min, $I_{SINK} = 3.2$ mA, ADM803L/M/J, ADM809L/M/J
			0.3	V	$V_{CC} > 1.0$ V, $I_{SINK} = 50$ μA
RESET OUTPUT VOLTAGE HIGH (ADM809)	$0.8 V_{CC}$			V	$V_{CC} > V_{TH}$ max, $I_{SOURCE} = 500$ μA , ADM809R/S/T/Z
	$V_{CC} - 1.5$			V	$V_{CC} > V_{TH}$ max, $I_{SOURCE} = 800$ μA , ADM809L/M/J
RESET OUTPUT VOLTAGE LOW (ADM810)			0.3	V	$V_{CC} = V_{TH}$ min, $I_{SINK} = 1.2$ mA, ADM810R/S/T/Z
			0.4	V	$V_{CC} = V_{TH}$ min, $I_{SINK} = 3.2$ mA, ADM810L/M/J
RESET OUTPUT VOLTAGE HIGH (ADM810)	$0.8 V_{CC}$			V	1.8 V $< V_{CC} < V_{TH}$ min, $I_{SOURCE} = 150$ μA
RESET OPEN-DRAIN OUTPUT Leakage Current (ADM803)			1	μA	$V_{CC} > V_{TH}$, reset de-asserted

ADM803/ADM809/ADM810

ABSOLUTE MAXIMUM RATINGS

T_A = 25°C, unless otherwise noted.

Table 1.

Parameter	Ratings
V _{CC}	−0.3 V to +6 V
RESET, $\overline{\text{RESET}}$	−0.3 V to V _{CC} + 0.5 V
Input Current V _{CC}	20 mA
Output Current RESET, $\overline{\text{RESET}}$ (push-pull)	20 mA
$\overline{\text{RESET}}$ (open drain)	−0.3 V to +6.0 V
Rate of Rise, V _{CC}	100 V/μs
θ _{JA} Thermal Impedance, SC70	146°C/W
θ _{JA} Thermal Impedance, SOT-23	270°C/W
Lead Temperature (Soldering, 10 sec)	300°C
Vapor Phase (60 sec)	215°C
Infrared (15 sec)	220°C
Storage Temperature Range	−65°C to +150°C

Stresses above those listed under Absolute Maximum Ratings may cause permanent damage to the device. This is a stress rating only; functional operation of the device at these or any other conditions above those indicated in the operational section of this specification is not implied. Exposure to absolute maximum rating conditions for extended periods may affect device reliability.

ESD CAUTION

ESD (electrostatic discharge) sensitive device. Electrostatic charges as high as 4000 V readily accumulate on the human body and test equipment and can discharge without detection. Although this product features proprietary ESD protection circuitry, permanent damage may occur on devices subjected to high energy electrostatic discharges. Therefore, proper ESD precautions are recommended to avoid performance degradation or loss of functionality.

Table 2. Reset Threshold Options

RESET Model	Threshold (V)
ADM8_L	4.63
ADM8_M	4.38
ADM8_J (ADM809/ADM810 only)	4.00
ADM8_T	3.08
ADM8_S	2.93
ADM8_R	2.63
ADM8_Z	2.32

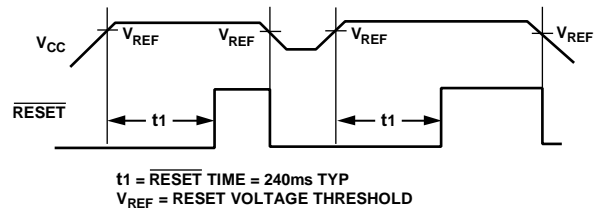

Figure 2. Power Fail Reset Timing

03796-003



PIN CONFIGURATION AND FUNCTION DESCRIPTIONS

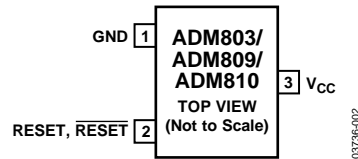

Figure 3. Pin Configuration

Table 3. Pin Function Descriptions

Pin No.	Mnemonic	Description
1	GND	Ground Reference for All Signals; 0 V.
2	RESET (ADM810)	Active Low Logic Output. RESET remains high while V_{CC} is below the reset threshold and remains high for 240 ms (typ) after V_{CC} rises above the reset threshold.
2	$\overline{\text{RESET}}$ (ADM803/ADM809)	Active Low Logic Output. $\overline{\text{RESET}}$ remains low while V_{CC} is below the reset threshold and remains low for 240 ms (typ) after V_{CC} rises above the reset threshold.
3	V_{CC}	Supply Voltage Being Monitored.

TYPICAL PERFORMANCE CHARACTERISTICS

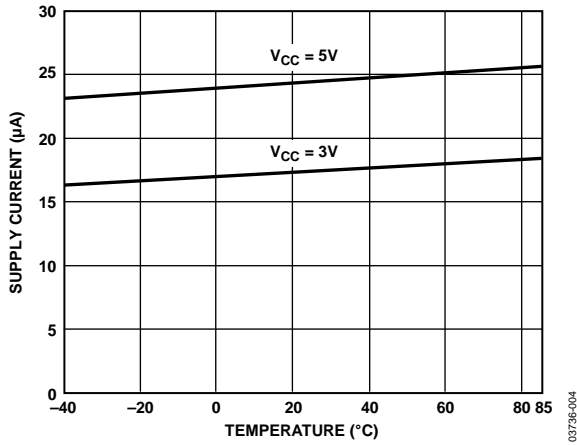

Figure 4. Supply Current vs. Temperature (No Load)

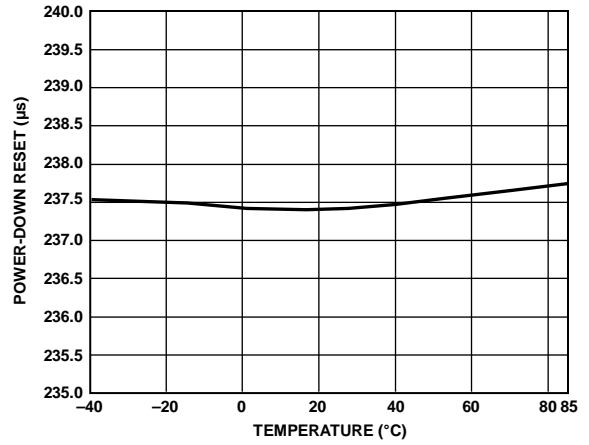

Figure 7. Power-Down RESET Delay vs. Temperature ADM8_R

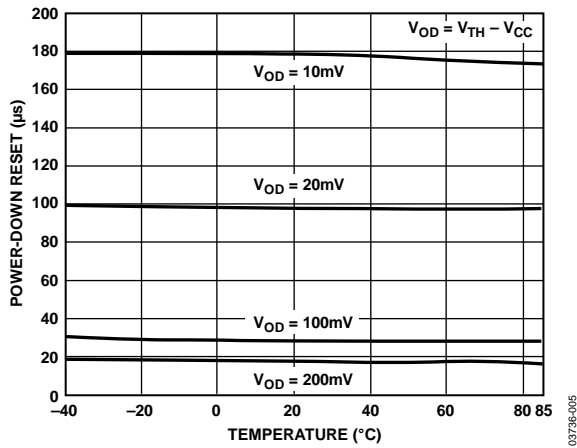

Figure 5. Power-Down RESET Delay vs. Temperature. ADM8_L/M/J

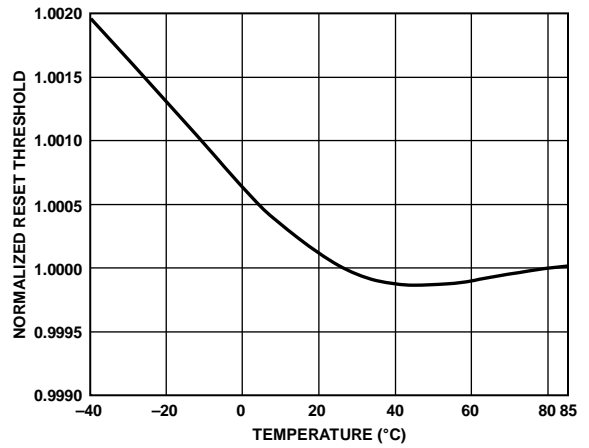

Figure 8. Normalized RESET Voltage Threshold vs. Temperature

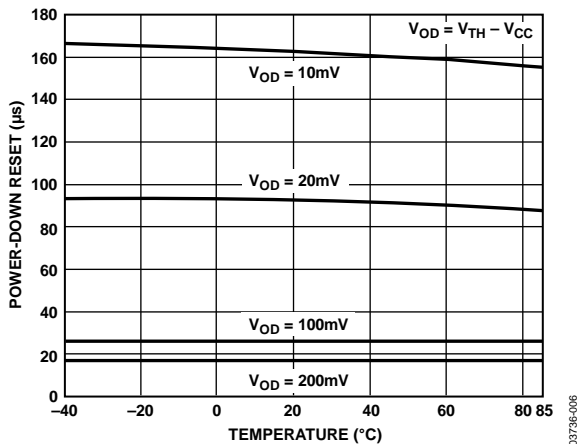

Figure 6. Power-Down RESET Delay vs. Temperature ADM8_T/S/R/Z

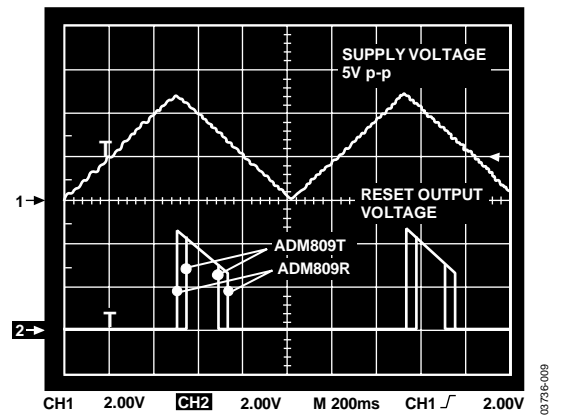

Figure 9. RESET Output Voltage vs. Supply Voltage

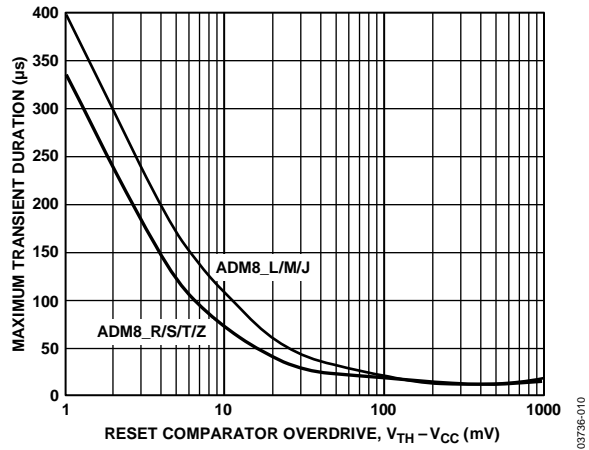

Figure 10. Maximum Transient Duration Without Causing a Reset Pulse vs. Reset Comparator Overdrive

INTERFACING TO OTHER DEVICES' OUTPUT

The ADM803/ADM809/ADM810 series is designed to integrate with as many devices as possible and, therefore, has a standard output dependent on V_{CC} . This enables the parts to be used in both 3 V and 5 V, or any nominal voltage within the minimum and maximum specifications for V_{CC} . This design simplifies interfacing the ADM803/ADM809/ADM810 to other devices.

ENSURING A VALID RESET OUTPUT DOWN TO $V_{CC} = 0$ V

When V_{CC} falls below 0.8 V, the ADM803/ADM809 RESET no longer sinks current. A high impedance CMOS logic input connected to RESET may, therefore, drift to undetermined logic levels. To eliminate this problem, a 100 k Ω resistor should be connected from RESET to ground.

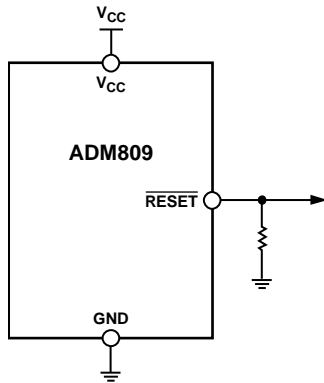

Figure 11. Ensuring a Valid Reset Output Down to $V_{CC} = 0$ V

BENEFITS OF AN ACCURATE RESET THRESHOLD

In other microprocessors, tolerances in supply voltages lead to an overall increase in reset tolerance levels due to the deterioration of the reset circuit's power supply. In the ADM803/ADM809/ADM810, the possibility of a malfunction during a power failure is greatly reduced because the devices can operate effectively even when there are large degradations of the supply voltages. Another advantage is the very accurate internal voltage reference circuit of the ADM803/ADM809/ADM810. These benefits combine to produce an exceptionally reliable voltage monitor circuit.

INTERFACING TO MICROPROCESSORS WITH MULTIPLE INTERRUPTS

In a number of cases, it is necessary to interface many interrupts from different devices (for example, thermal, altitude, and velocity sensors). The ADM803/ADM809/ADM810 can easily be integrated into existing interrupt-handling circuits, as shown in Figure 12, or can be used as standalone devices.

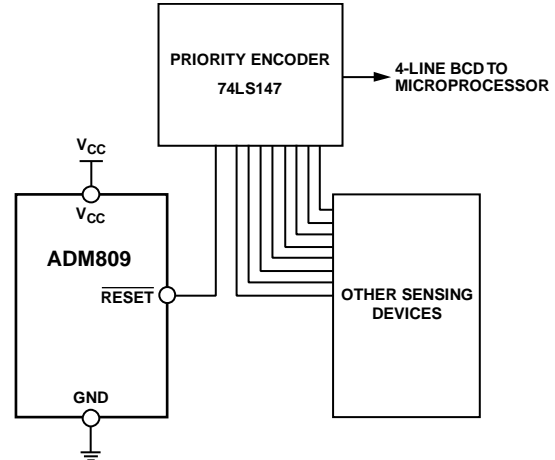
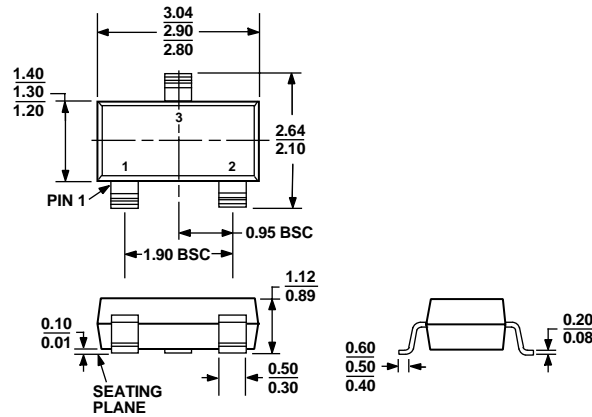

Figure 12. Interfacing to Microprocessors with Multiple Interrupts

OUTLINE DIMENSIONS



COMPLIANT TO JEDEC STANDARDS TO-236-AB

Figure 13. 3-Lead Small Outline Transistor Package [SOT-23-3] (RT-3)

Dimensions shown in millimeters

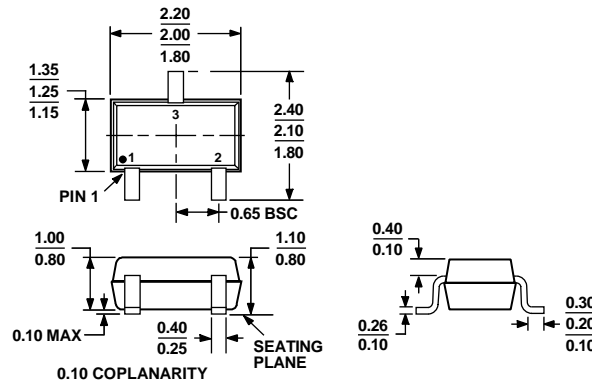

ALL DIMENSIONS COMPLIANT WITH EIAJ SC70

Figure 14. 3-Lead Thin Shrink Small Outline Transistor Package [SC70] (KS-3)

Dimensions shown in millimeters

111505-0

ORDERING GUIDE

Model	Threshold Reset (V)	Temperature Range	Branding ¹	Quantity	Package Description	Package Option
ADM803LAKS-REEL	4.63	-40°C to +125°C	M02	10k	3-Lead SC70	KS-3
ADM803LAKS-REEL7	4.63	-40°C to +125°C	M02	3k	3-Lead SC70	KS-3
ADM803LAKSZ-REEL ²	4.63	-40°C to +125°C	M6L	10k	3-Lead SC70	KS-3
ADM803LAKSZ-REEL7 ²	4.63	-40°C to +125°C	M6L	3k	3-Lead SC70	KS-3
ADM803MAKS-REEL7	4.38	-40°C to +125°C	M03	3k	3-Lead SC70	KS-3
ADM803MAKSZ-REEL ²	4.38	-40°C to +125°C	M6J	10k	3-Lead SC70	KS-3
ADM803MAKSZ-REEL7 ²	4.38	-40°C to +125°C	M6J	3k	3-Lead SC70	KS-3
ADM803RAKS-REEL7	2.63	-40°C to +125°C	M07	3k	3-Lead SC70	KS-3
ADM803RAKSZ-REEL ²	2.63	-40°C to +125°C	M6M	10k	3-Lead SC70	KS-3
ADM803RAKSZ-REEL7 ²	2.63	-40°C to +125°C	M6M	3k	3-Lead SC70	KS-3
ADM803SAKS-REEL	2.93	-40°C to +125°C	M06	10k	3-Lead SC70	KS-3
ADM803SAKS-REEL7	2.93	-40°C to +125°C	M06	3k	3-Lead SC70	KS-3
ADM803SAKSZ-REEL ²	2.93	-40°C to +125°C	M50	10k	3-Lead SC70	KS-3
ADM803SAKSZ-REEL7 ²	2.93	-40°C to +125°C	M50	3k	3-Lead SC70	KS-3
ADM803TAKS-REEL	3.08	-40°C to +125°C	M05	10k	3-Lead SC70	KS-3

ADM803/ADM809/ADM810

Model	Threshold Reset (V)	Temperature Range	Branding ¹	Quantity	Package Description	Package Option
ADM803TAKS-REEL7	3.08	-40°C to +125°C	M05	3k	3-Lead SC70	KS-3
ADM803TAKSZ-REEL ²	3.08	-40°C to +125°C	M4M	10k	3-Lead SC70	KS-3
ADM803TAKSZ-REEL7 ²	3.08	-40°C to +125°C	M4M	3k	3-Lead SC70	KS-3
ADM803ZAKS-REEL	2.32	-40°C to +125°C	M08	10k	3-Lead SC70	KS-3
ADM803ZAKS-REEL7	2.32	-40°C to +125°C	M08	3k	3-Lead SC70	KS-3
ADM803ZAKSZ-REEL ²	2.32	-40°C to +125°C	M6N	10k	3-Lead SC70	KS-3
ADM803ZAKSZ-REEL7 ²	2.32	-40°C to +125°C	M6N	3k	3-Lead SC70	KS-3
ADM809JAKS-REEL	4.00	-40°C to +125°C		10k	3-Lead SC70	KS-3
ADM809JAKS-REEL7	4.00	-40°C to +125°C	M9C or 9JXX	3k	3-Lead SC70	KS-3
ADM809JAKSZ-REEL ²	4.00	-40°C to +125°C	M6P	10k	3-Lead SC70	KS-3
ADM809JAKSZ-REEL7 ²	4.00	-40°C to +125°C	M6P	3k	3-Lead SC70	KS-3
ADM809JART-REEL7	4.00	-40°C to +125°C	M9C or 9JXX	3k	3-Lead SOT-23	RT-3
ADM809JARTZ-REEL ²	4.00	-40°C to +125°C	M6P	10k	3-Lead SOT-23	RT-3
ADM809JARTZ-REEL7 ²	4.00	-40°C to +125°C	M6P	3k	3-Lead SOT-23	RT-3
ADM809LAKS-REEL7	4.63	-40°C to +125°C	M9A	3k	3-Lead SC70	KS-3
ADM809LAKSZ-REEL ²	4.63	-40°C to +125°C	M6R	10k	3-Lead SC70	KS-3
ADM809LAKSZ-REEL7 ²	4.63	-40°C to +125°C	M6R	3k	3-Lead SC70	KS-3
ADM809LART-REEL	4.63	-40°C to +125°C	9LXX	10k	3-Lead SOT-23	RT-3
ADM809LART-REEL7	4.63	-40°C to +125°C	9LXX	3k	3-Lead SOT-23	RT-3
ADM809LARTZ-REEL ²	4.63	-40°C to +125°C	9LXX ³	10k	3-Lead SOT-23	RT-3
ADM809LARTZ-REEL7 ²	4.63	-40°C to +125°C	9LXX ³	3k	3-Lead SOT-23	RT-3
ADM809MAKS-REEL	4.38	-40°C to +125°C	M9B	10k	3-Lead SC70	KS-3
ADM809MAKS-REEL7	4.38	-40°C to +125°C	M9B	3k	3-Lead SC70	KS-3
ADM809MAKSZ-REEL ²	4.38	-40°C to +125°C	M51	10k	3-Lead SC70	KS-3
ADM809MAKSZ-REEL7 ²	4.38	-40°C to +125°C	M51	3k	3-Lead SC70	KS-3
ADM809MART-REEL	4.38	-40°C to +125°C	9MXX	10k	3-Lead SOT-23	RT-3
ADM809MART-REEL7	4.38	-40°C to +125°C	9MXX	3k	3-Lead SOT-23	RT-3
ADM809MARTZ-REEL ²	4.38	-40°C to +125°C	M51	10k	3-Lead SOT-23	RT-3
ADM809MARTZ-REEL7 ²	4.38	-40°C to +125°C	M51	3k	3-Lead SOT-23	RT-3
ADM809RAKS-REEL	2.63	-40°C to +125°C	M9F	10k	3-Lead SC70	KS-3
ADM809RAKS-REEL7	2.63	-40°C to +125°C	M9F	3k	3-Lead SC70	KS-3
ADM809RAKSZ-REEL ²	2.63	-40°C to +125°C	M4D	10k	3-Lead SC70	KS-3
ADM809RAKSZ-REEL7 ²	2.63	-40°C to +125°C	M4D	3k	3-Lead SC70	KS-3
ADM809RART-REEL	2.63	-40°C to +125°C	9RXX	10k	3-Lead SOT-23	RT-3
ADM809RART-REEL7	2.63	-40°C to +125°C	9RXX	3k	3-Lead SOT-23	RT-3
ADM809RARTZ-REEL ²	2.63	-40°C to +125°C	M4D	10k	3-Lead SOT-23	RT-3
ADM809RARTZ-REEL7 ²	2.63	-40°C to +125°C	M4D	3k	3-Lead SOT-23	RT-3
ADM809SAKS-REEL	2.93	-40°C to +125°C	M9E	10k	3-Lead SC70	KS-3
ADM809SAKS-REEL7	2.93	-40°C to +125°C	M9E	3k	3-Lead SC70	KS-3
ADM809SAKSZ-REEL ²	2.93	-40°C to +125°C	M53	10k	3-Lead SC70	KS-3
ADM809SAKSZ-REEL7 ²	2.93	-40°C to +125°C	M53	3k	3-Lead SC70	KS-3
ADM809SART-REEL	2.93	-40°C to +125°C	9SXX	10k	3-Lead SOT-23	RT-3
ADM809SART-REEL7	2.93	-40°C to +125°C	9SXX	3k	3-Lead SOT-23	RT-3
ADM809SARTZ-REEL ²	2.93	-40°C to +125°C	M53	10k	3-Lead SOT-23	RT-3
ADM809SARTZ-REEL7 ²	2.93	-40°C to +125°C	M53	3k	3-Lead SOT-23	RT-3
ADM809TAKS-REEL7	3.08	-40°C to +125°C	M9D	3k	3-Lead SC70	KS-3
ADM809TAKSZ-REEL ²	3.08	-40°C to +125°C	M4K	10k	3-Lead SC70	KS-3
ADM809TAKSZ-REEL7 ²	3.08	-40°C to +125°C	M4K	3k	3-Lead SC70	KS-3
ADM809TART-REEL	3.08	-40°C to +125°C	9TXX	10k	3-Lead SOT-23	RT-3
ADM809TART-REEL7	3.08	-40°C to +125°C	9TXX	3k	3-Lead SOT-23	RT-3
ADM809TARTZ-REEL ²	3.08	-40°C to +125°C	9TXX ³	10k	3-Lead SOT-23	RT-3
ADM809TARTZ-REEL7 ²	3.08	-40°C to +125°C	9TXX ³	3k	3-Lead SOT-23	RT-3

ADM803/ADM809/ADM810

Model	Threshold Reset (V)	Temperature Range	Branding ¹	Quantity	Package Description	Package Option
ADM809ZAKS-REEL	2.32	-40°C to +125°C	M9G	10k	3-Lead SC70	KS-3
ADM809ZAKS-REEL7	2.32	-40°C to +125°C	M9G	3k	3-Lead SC70	KS-3
ADM809ZAKSZ-REEL ²	2.32	-40°C to +125°C	M4P	10k	3-Lead SC70	KS-3
ADM809ZAKSZ-REEL7 ²	2.32	-40°C to +125°C	M4P	3k	3-Lead SC70	KS-3
ADM809ZART-REEL	2.32	-40°C to +125°C	9ZXX	10k	3-Lead SOT-23	RT-3
ADM809ZART-REEL7	2.32	-40°C to +125°C	9ZXX	3k	3-Lead SOT-23	RT-3
ADM809ZARTZ-REEL ²	2.32	-40°C to +125°C	M4P	10k	3-Lead SOT-23	RT-3
ADM809ZARTZ-REEL7 ²	2.32	-40°C to +125°C	M4P	3k	3-Lead SOT-23	RT-3
ADM810JAKS-REEL	4.00	-40°C to +125°C	MAC or AJXX	10k	3-Lead SC70	KS-3
ADM810JAKS-REEL7	4.00	-40°C to +125°C	MAC or AJXX	3k	3-Lead SC70	KS-3
ADM810JAKSZ-REEL ²	4.00	-40°C to +125°C	M6V	10k	3-Lead SC70	KS-3
ADM810JAKSZ-REEL7 ²	4.00	-40°C to +125°C	M6V	3k	3-Lead SC70	KS-3
ADM810JART-REEL7	4.00	-40°C to +125°C	MAC or AJXX	3k	3-Lead SOT-23	RT-3
ADM810JARTZ-REEL ²	4.00	-40°C to +125°C	M6V	10k	3-Lead SOT-23	RT-3
ADM810JARTZ-REEL7 ²	4.00	-40°C to +125°C	M6V	3k	3-Lead SOT-23	RT-3
ADM810LAKS-REEL7	4.63	-40°C to +125°C	MAA or ALXX	3k	3-Lead SC70	KS-3
ADM810LAKSZ-REEL ²	4.63	-40°C to +125°C	M6W or ALXX	10k	3-Lead SC70	KS-3
ADM810LAKSZ-REEL7 ²	4.63	-40°C to +125°C	M6W or ALXX	3k	3-Lead SC70	KS-3
ADM810LART-REEL	4.63	-40°C to +125°C	MAA or ALXX	10k	3-Lead SOT-23	RT-3
ADM810LART-REEL7	4.63	-40°C to +125°C	MAA or ALXX	3k	3-Lead SOT-23	RT-3
ADM810LARTZ-REEL ²	4.63	-40°C to +125°C	M6W or ALXX	10k	3-Lead SOT-23	RT-3
ADM810LARTZ-REEL7 ²	4.63	-40°C to +125°C	M6W or ALXX	3k	3-Lead SOT-23	RT-3
ADM810MAKS-REEL7	4.38	-40°C to +125°C	MAB or AMXX	3k	3-Lead SC70	KS-3
ADM810MAKSZ-REEL ²	4.38	-40°C to +125°C	M6S	10k	3-Lead SC70	KS-3
ADM810MAKSZ-REEL7 ²	4.38	-40°C to +125°C	M6S	3k	3-Lead SC70	KS-3
ADM810MART-REEL7	4.38	-40°C to +125°C	MAB or AMXX	3k	3-Lead SOT-23	RT-3
ADM810MARTZ-REEL ²	4.38	-40°C to +125°C	M6S	10k	3-Lead SOT-23	RT-3
ADM810MARTZ-REEL7 ²	4.38	-40°C to +125°C	M6S	3k	3-Lead SOT-23	RT-3
ADM810RAKS-REEL	2.63	-40°C to +125°C	MAF	10k	3-Lead SC70	KS-3
ADM810RAKS-REEL7	2.63	-40°C to +125°C	MAF	3k	3-Lead SC70	KS-3
ADM810RAKSZ-REEL ²	2.63	-40°C to +125°C	M52 or ARXX	10k	3-Lead SC70	KS-3
ADM810RAKSZ-REEL7 ²	2.63	-40°C to +125°C	M52 or ARXX	3k	3-Lead SC70	KS-3
ADM810RART-REEL7	2.63	-40°C to +125°C	ARXX	3k	3-Lead SOT-23	RT-3
ADM810RARTZ-REEL ²	2.63	-40°C to +125°C	M52 or ARXX	10k	3-Lead SOT-23	RT-3
ADM810RARTZ-REEL7 ²	2.63	-40°C to +125°C	M52 or ARXX	3k	3-Lead SOT-23	RT-3
ADM810SAKS-REEL7	2.93	-40°C to +125°C	MAE or ASXX	3k	3-Lead SC70	KS-3
ADM810SAKSZ-REEL ²	2.93	-40°C to +125°C	M6T	10k	3-Lead SC70	KS-3
ADM810SAKSZ-REEL7 ²	2.93	-40°C to +125°C	M6T	3k	3-Lead SC70	KS-3
ADM810SART-REEL	2.93	-40°C to +125°C	MAE or ASXX	10k	3-Lead SOT-23	RT-3
ADM810SART-REEL7	2.93	-40°C to +125°C	MAE or ASXX	3k	3-Lead SOT-23	RT-3
ADM810SARTZ-REEL ²	2.93	-40°C to +125°C	M6T	10k	3-Lead SOT-23	RT-3
ADM810SARTZ-REEL7 ²	2.93	-40°C to +125°C	M6T	3k	3-Lead SOT-23	RT-3
ADM810TAKS-REEL	3.08	-40°C to +125°C	MAD or ATXX	10k	3-Lead SC70	KS-3
ADM810TAKS-REEL7	3.08	-40°C to +125°C	MAD or ATXX	3k	3-Lead SC70	KS-3
ADM810TAKSZ-REEL ²	3.08	-40°C to +125°C	M4V	10k	3-Lead SC70	KS-3
ADM810TAKSZ-REEL7 ²	3.08	-40°C to +125°C	M4V	3k	3-Lead SC70	KS-3
ADM810TART-REEL7	3.08	-40°C to +125°C	MAD or ATXX	3k	3-Lead SOT-23	RT-3
ADM810TARTZ-REEL ²	3.08	-40°C to +125°C	M4V	10k	3-Lead SOT-23	RT-3
ADM810TARTZ-REEL7 ²	3.08	-40°C to +125°C	M4V	3k	3-Lead SOT-23	RT-3
ADM810ZAKS-REEL	2.32	-40°C to +125°C	MAG or AZXX	10k	3-Lead SC70	KS-3
ADM810ZAKS-REEL7	2.32	-40°C to +125°C	MAG or AZXX	3k	3-Lead SC70	KS-3
ADM810ZAKSZ-REEL ²	2.32	-40°C to +125°C	M6U	10k	3-Lead SC70	KS-3

ADM803/ADM809/ADM810

Model	Threshold Reset (V)	Temperature Range	Branding ¹	Quantity	Package Description	Package Option
ADM810ZAKSZ-REEL7 ²	2.32	-40°C to +125°C	M6U	3k	3-Lead SC70	KS-3
ADM810ZART-REEL	2.32	-40°C to +125°C	MAG or AZXX	10k	3-Lead SOT-23	RT-3
ADM810ZART-REEL7	2.32	-40°C to +125°C	MAG or AZXX	3k	3-Lead SOT-23	RT-3
ADM810ZARTZ-REEL ²	2.32	-40°C to +125°C	M6U	10k	3-Lead SOT-23	RT-3
ADM810ZARTZ-REEL7 ²	2.32	-40°C to +125°C	M6U	3k	3-Lead SOT-23	RT-3

¹ XX = Date code, may be top or bottom marked.

² Z = Pb-free part.

³ Pb-free part has XX branded on the bottom of the device.