



CURRENT SHUNT MONITOR

-16V to +80V Common-Mode Range

Check for Samples: [INA193](#), [INA194](#), [INA195](#), [INA196](#), [INA197](#), [INA198](#)

FEATURES

- **WIDE COMMON-MODE VOLTAGE:**
-16V to +80V
- **LOW ERROR: 3.0% Over Temp (max)**
- **BANDWIDTH: Up to 500kHz**
- **THREE TRANSFER FUNCTIONS AVAILABLE:**
20V/V, 50V/V, and 100V/V
- **QUIESCENT CURRENT: 900 μ A (max)**
- **COMPLETE CURRENT SENSE SOLUTION**

APPLICATIONS

- **WELDING EQUIPMENT**
- **NOTEBOOK COMPUTERS**
- **CELL PHONES**
- **TELECOM EQUIPMENT**
- **AUTOMOTIVE**
- **POWER MANAGEMENT**
- **BATTERY CHARGERS**

DESCRIPTION

The INA193–INA198 family of current shunt monitors with voltage output can sense drops across shunts at common-mode voltages from -16V to +80V, independent of the INA19x supply voltage. They are available with three output voltage scales: 20V/V, 50V/V, and 100V/V. The 500kHz bandwidth simplifies use in current control loops. The INA193–INA195 provide identical functions but alternative pin configurations to the INA196–INA198, respectively.

The INA193–INA198 operate from a single +2.7V to +18V supply, drawing a maximum of 900 μ A of supply current. They are specified over the extended operating temperature range (-40°C to +125°C), and are offered in a space-saving SOT23 package.

MODEL	GAIN	PACKAGE	PINOUT ⁽¹⁾
INA193	20V/V	SOT23-5	Pinout #1
INA194	50V/V	SOT23-5	Pinout #1
INA195	100V/V	SOT23-5	Pinout #1
INA196	20V/V	SOT23-5	Pinout #2
INA197	50V/V	SOT23-5	Pinout #2
INA198	100V/V	SOT23-5	Pinout #2

(1) See [Pin Assignments](#) for Pinout #1 and Pinout #2.

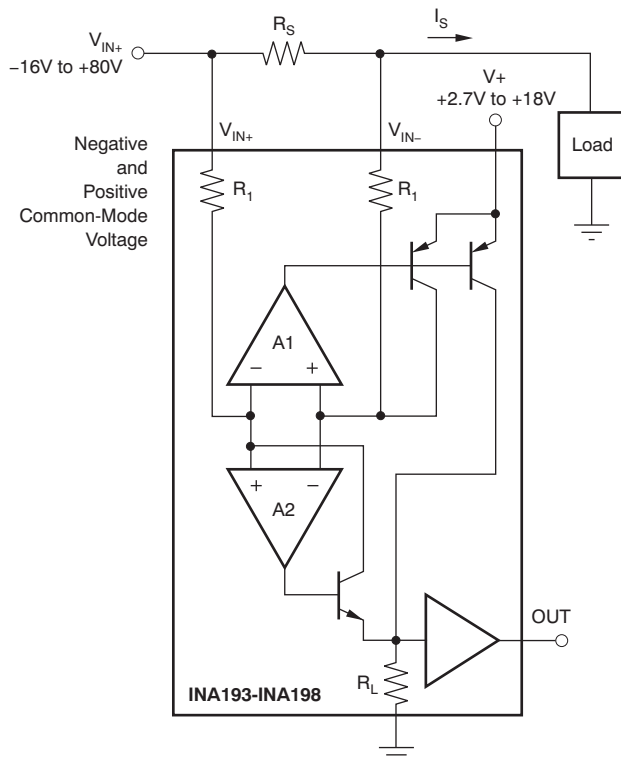

Please be aware that an important notice concerning availability, standard warranty, and use in critical applications of Texas Instruments semiconductor products and disclaimers thereto appears at the end of this data sheet.

All trademarks are the property of their respective owners.



This integrated circuit can be damaged by ESD. Texas Instruments recommends that all integrated circuits be handled with appropriate precautions. Failure to observe proper handling and installation procedures can cause damage.

ESD damage can range from subtle performance degradation to complete device failure. Precision integrated circuits may be more susceptible to damage because very small parametric changes could cause the device not to meet its published specifications.

PACKAGE INFORMATION⁽¹⁾

PRODUCT	PACKAGE-LEAD	PACKAGE DESIGNATOR	PACKAGE MARKING
INA193	SOT23-5	DBV	BJJ
INA194	SOT23-5	DBV	BJI
INA195	SOT23-5	DBV	BJK
INA196	SOT23-5	DBV	BJE
INA197	SOT23-5	DBV	BJH
INA198	SOT23-5	DBV	BJL

(1) For the most current package and ordering information see the Package Option Addendum at the end of this document, or see the TI web site at www.ti.com.

ABSOLUTE MAXIMUM RATINGS⁽¹⁾

	INA19x	UNIT
Supply Voltage	+18	V
Analog Inputs, V_{IN+} , V_{IN-} Differential (V_{IN+}) – (V_{IN-})	–18 to +18	V
Common-Mode ⁽²⁾	–16 to +80	V
Analog Output, Out ⁽²⁾	GND – 0.3 to (V+) + 0.3	V
Input Current Into Any Pin ⁽²⁾	5	mA
Operating Temperature	–55 to +150	°C
Storage Temperature	–65 to +150	°C
Junction Temperature	+150	°C
ESD Ratings	Human Body Model (HBM)	4000
	Charged-Device Model (CDM)	1000

- (1) Stresses above these ratings may cause permanent damage. Exposure to absolute maximum conditions for extended periods may degrade device reliability. These are stress ratings only, and functional operation of the device at these or any other conditions beyond those specified is not supported.
- (2) Input voltage at any pin may exceed the voltage shown if the current at that pin is limited to 5mA.

PIN ASSIGNMENTS

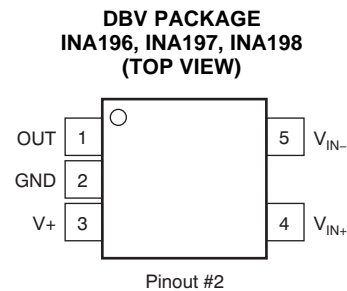
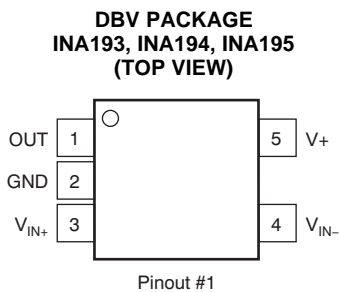

ELECTRICAL CHARACTERISTICS: $V_S = +12V$
Boldface limits apply over the specified temperature range, $T_A = -40^{\circ}C$ to $+125^{\circ}C$.

All specifications at $T_A = +25^{\circ}C$, $V_S = +12V$, $V_{IN+} = 12V$, and $V_{SENSE} = 100mV$, unless otherwise noted.

PARAMETER	TEST CONDITIONS	INA193, INA194, INA195, INA196, INA197, INA198			UNIT
		MIN	TYP	MAX	
INPUT					
Full-Scale Input Voltage	V_{SENSE} $V_{SENSE} = V_{IN+} - V_{IN-}$		0.15	$(V_S - 0.2)/Gain$	V
Common-Mode Input Range	V_{CM}	-16		80	V
Common-Mode Rejection	CMR $V_{IN+} = -16V$ to $+80V$	80	94		dB
Over Temperature	$V_{IN+} = +12V$ to $+80V$	100	120		dB
Offset Voltage, RTI	V_{OS}		± 0.5	2	mV
Over Temperature			0.5	3	mV
vs Temperature	dV_{OS}/dT		2.5		$\mu V/^{\circ}C$
vs Power Supply	PSR $V_S = +2.7V$ to $+18V$, $V_{IN+} = +18V$		5	100	$\mu V/V$
Input Bias Current, V_{IN-} pin	I_B		± 8	± 16	μA
OUTPUT ($V_{SENSE} \geq 20mV$)					
Gain: INA193, INA196	G		20		V/V
Gain: INA194, INA197			50		V/V
Gain: INA195, INA198			100		V/V
Gain Error	$V_{SENSE} = 20mV$ to $100mV$, $T_A = +25^{\circ}C$		± 0.2	± 1	%
Over Temperature	$V_{SENSE} = 20mV$ to $100mV$			± 2	%
Total Output Error ⁽¹⁾	$V_{SENSE} = 100mV$		± 0.75	± 2.2	%
Over Temperature			± 1	± 3	%
Nonlinearity Error	$V_{SENSE} = 20mV$ to $100mV$		± 0.002	± 0.1	%
Output Impedance	R_O		1.5		Ω
Maximum Capacitive Load	No Sustained Oscillation		10		nF
OUTPUT ($V_{SENSE} < 20mV$)⁽²⁾					
All Devices	$-16V \leq V_{CM} < 0V$		300		mV
INA193, INA196	$0V \leq V_{CM} \leq V_S$, $V_S = 5V$			0.4	V
INA194, INA197	$0V \leq V_{CM} \leq V_S$, $V_S = 5V$			1	V
INA195, INA198	$0V \leq V_{CM} \leq V_S$, $V_S = 5V$			2	V
All Devices	$V_S < V_{CM} \leq 80V$		300		mV
VOLTAGE OUTPUT⁽³⁾					
Swing to V+ Power-Supply Rail	$R_L = 100k\Omega$ to GND		$(V+) - 0.1$	$(V+) - 0.2$	V
Swing to GND⁽⁴⁾			$(V_{GND}) + 3$	$(V_{GND}) + 50$	mV
FREQUENCY RESPONSE					
Bandwidth, INA193, INA196	BW $C_{LOAD} = 5pF$		500		kHz
Bandwidth, INA194, INA197	$C_{LOAD} = 5pF$		300		kHz
Bandwidth, INA195, INA198	$C_{LOAD} = 5pF$		200		kHz
Phase Margin	$C_{LOAD} < 10nF$		40		degrees
Slew Rate	SR		1		V/ μs
Settling Time (1%)	t_s $V_{SENSE} = 10mV$ to $100mV_{PP}$, $C_{LOAD} = 5pF$		2		μs
NOISE, RTI					
Voltage Noise Density			40		nV/ \sqrt{Hz}

(1) Total output error includes effects of gain error and V_{OS} .

(2) For details on this region of operation, see the [Accuracy Variations](#) section in the [Applications Information](#).

(3) See Typical Characteristic curve *Output Swing vs Output Current*, [Figure 7](#).

(4) Specified by design.

ELECTRICAL CHARACTERISTICS: $V_S = +12V$ (continued)

Boldface limits apply over the specified temperature range, $T_A = -40^{\circ}C$ to $+125^{\circ}C$.

All specifications at $T_A = +25^{\circ}C$, $V_S = +12V$, $V_{IN+} = 12V$, and $V_{SENSE} = 100mV$, unless otherwise noted.

PARAMETER	TEST CONDITIONS	INA193, INA194, INA195, INA196, INA197, INA198			UNIT
		MIN	TYP	MAX	
POWER SUPPLY					
Operating Range	V_S	+2.7		+18	V
Quiescent Current	I_Q		700	900	μA
Over Temperature	$V_{OUT} = 2V$ $V_{SENSE} = 0mV$		370	950	μA
TEMPERATURE RANGE					
Specified Temperature Range		-40		+125	$^{\circ}C$
Operating Temperature Range		-55		+150	$^{\circ}C$
Storage Temperature Range		-65		+150	$^{\circ}C$
Thermal Resistance, SOT23	θ_{JA}		200		$^{\circ}C/W$

TYPICAL CHARACTERISTICS

All specifications at $T_A = +25^\circ\text{C}$, $V_S = +12\text{V}$, and $V_{IN+} = 12\text{V}$, and $V_{SENSE} = 100\text{mV}$, unless otherwise noted.

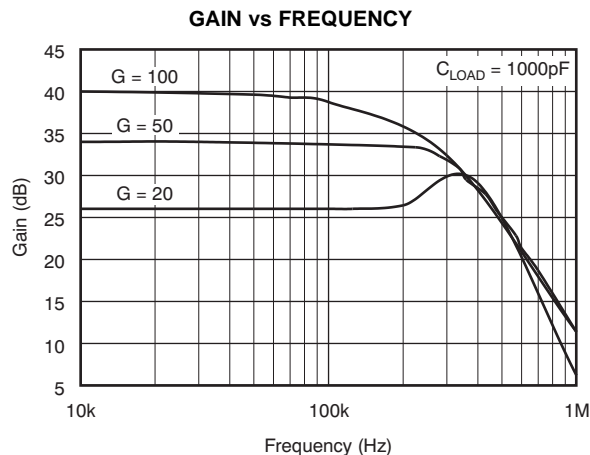

Figure 1.

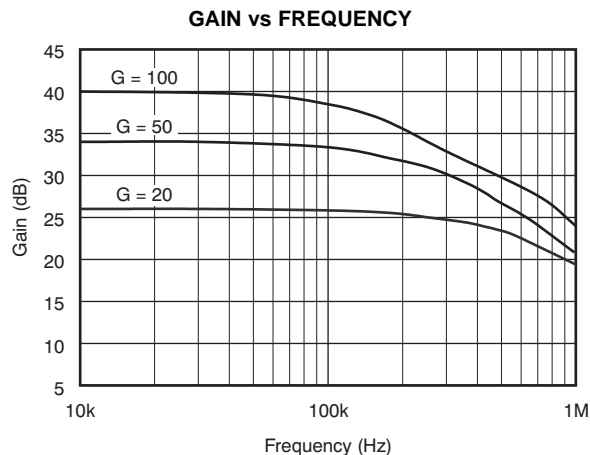

Figure 2.

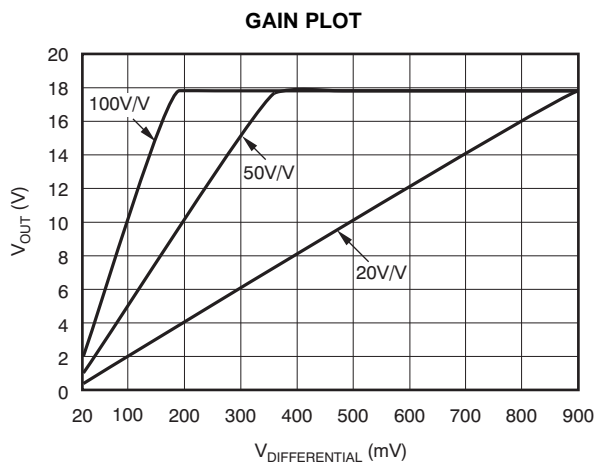

Figure 3.

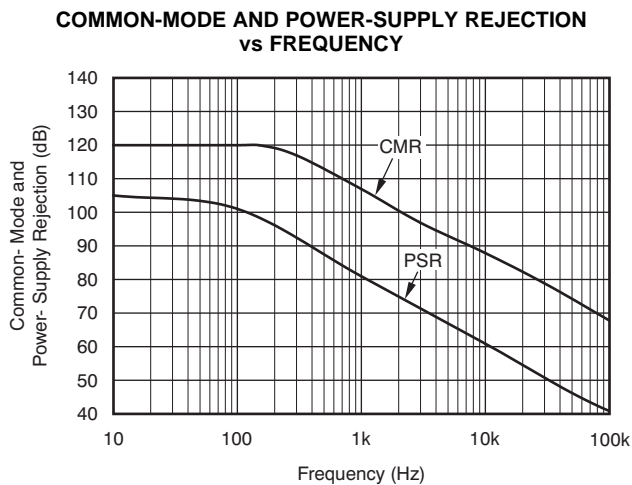

Figure 4.

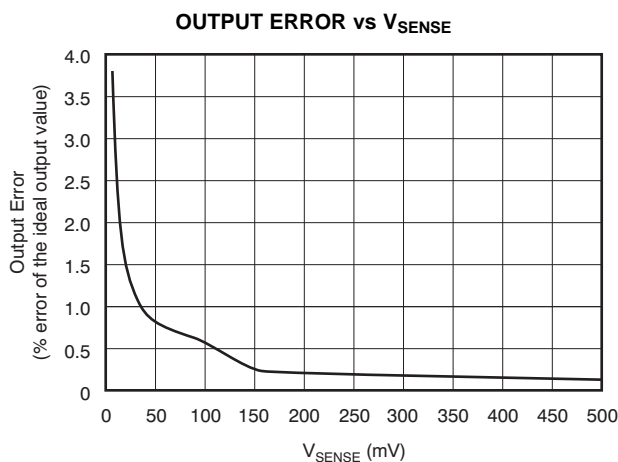

Figure 5.

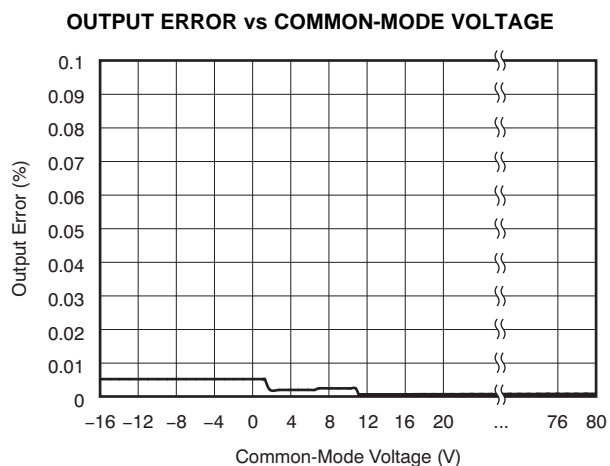

Figure 6.

TYPICAL CHARACTERISTICS (continued)

All specifications at $T_A = +25^\circ\text{C}$, $V_S = +12\text{V}$, and $V_{IN+} = 12\text{V}$, and $V_{SENSE} = 100\text{mV}$, unless otherwise noted.

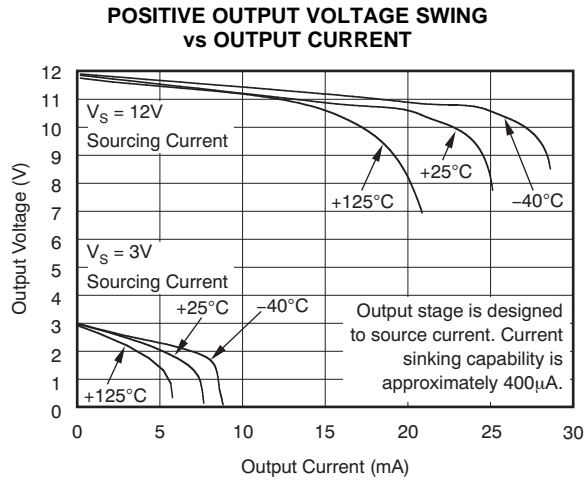

Figure 7.

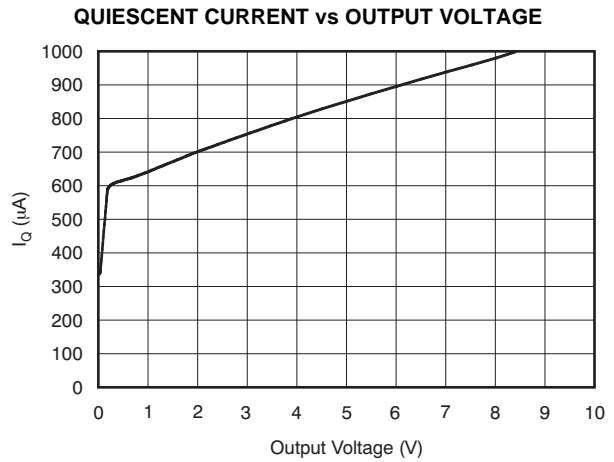

Figure 8.

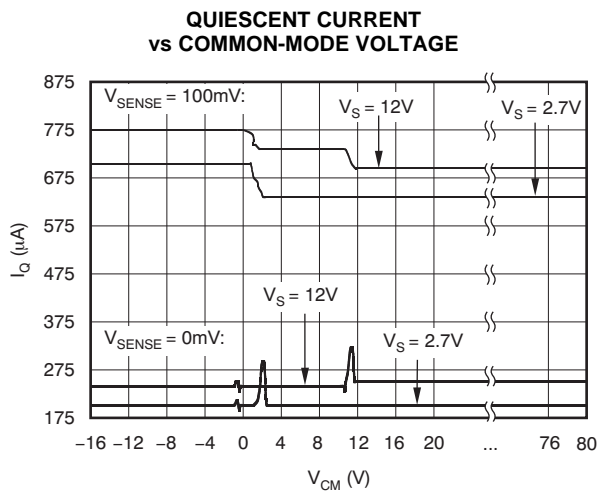

Figure 9.

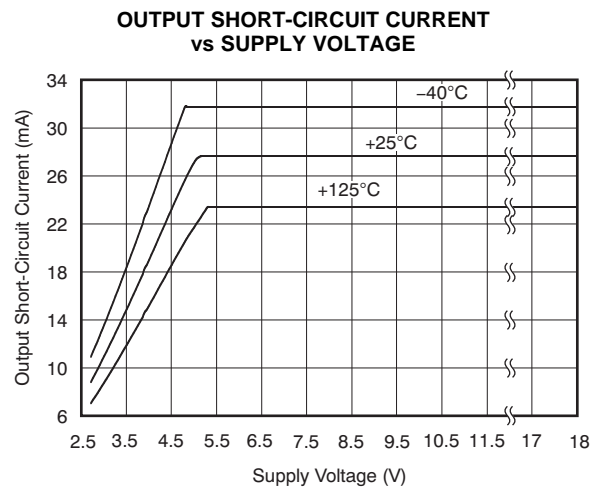

Figure 10.

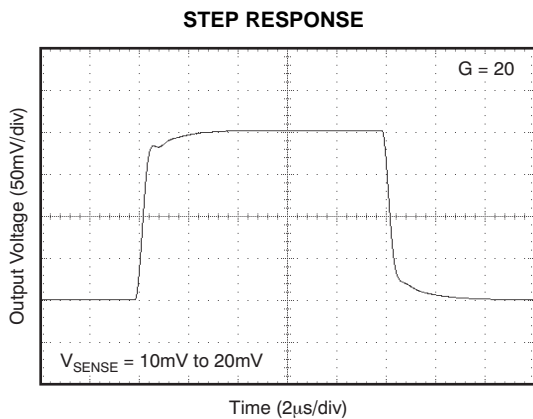

Figure 11.

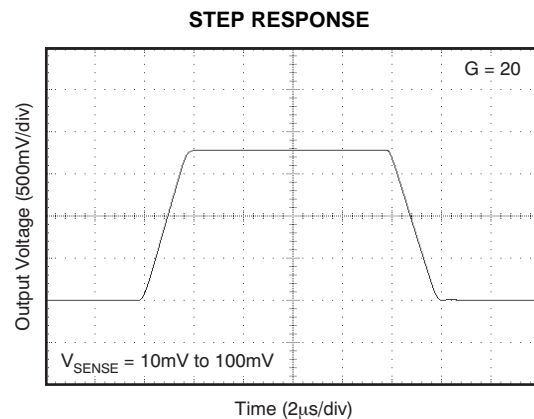
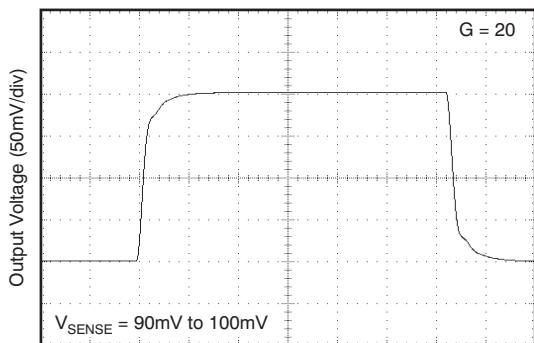

Figure 12.

TYPICAL CHARACTERISTICS (continued)

All specifications at $T_A = +25^\circ\text{C}$, $V_S = +12\text{V}$, and $V_{IN+} = 12\text{V}$, and $V_{SENSE} = 100\text{mV}$, unless otherwise noted.

STEP RESPONSE



Time (2µs/div)

Figure 13.

STEP RESPONSE

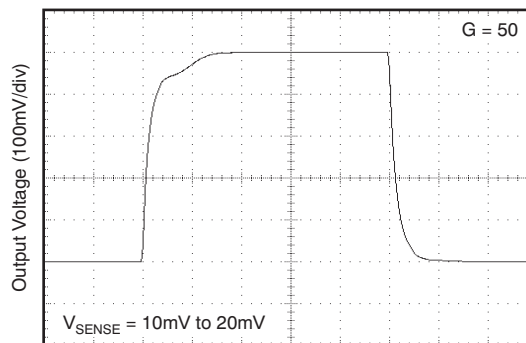

Time (5µs/div)

Figure 14.

STEP RESPONSE

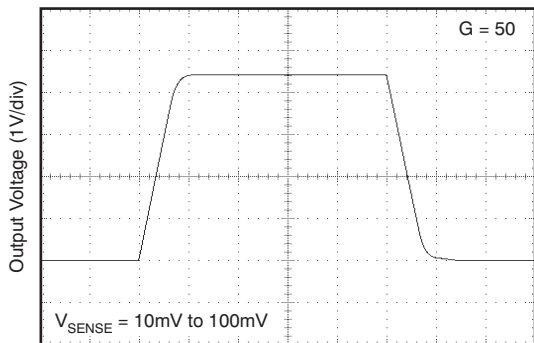

Time (5µs/div)

Figure 15.

STEP RESPONSE

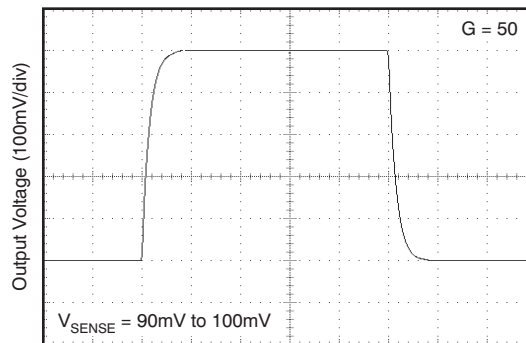

Time (5µs/div)

Figure 16.

STEP RESPONSE

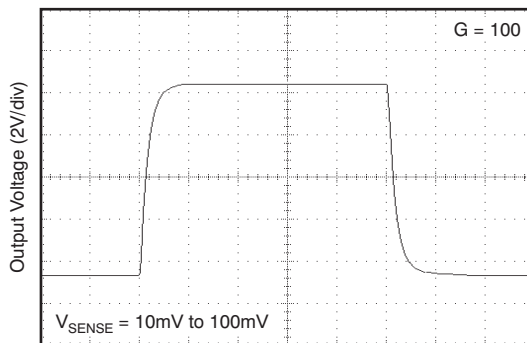

Time (10µs/div)

Figure 17.

APPLICATIONS INFORMATION

BASIC CONNECTION

Figure 18 shows the basic connection of the INA193-INA198. The input pins, V_{IN+} and V_{IN-} , should be connected as closely as possible to the shunt resistor to minimize any resistance in series with the shunt resistance.

Power-supply bypass capacitors are required for stability. Applications with noisy or high impedance power supplies may require additional decoupling capacitors to reject power-supply noise. Connect bypass capacitors close to the device pins.

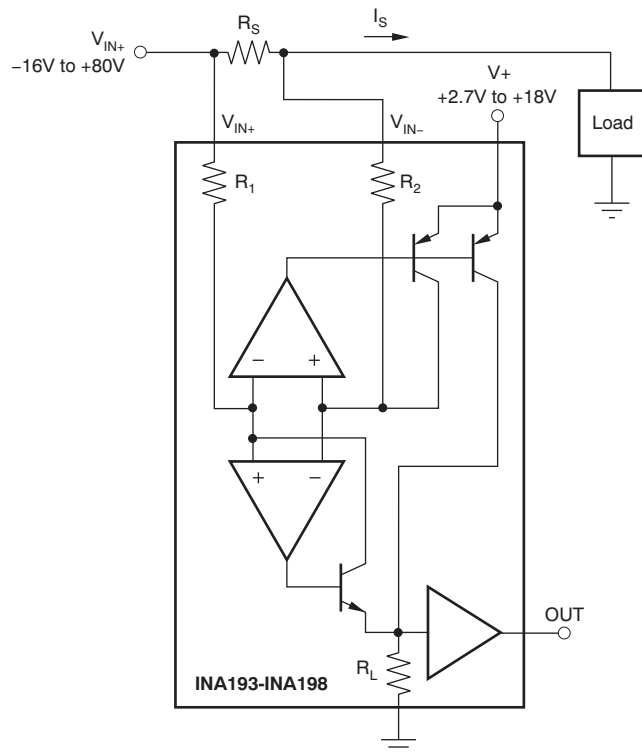

Figure 18. INA193-INA198 Basic Connection

POWER SUPPLY

The input circuitry of the INA193-INA198 can accurately measure beyond its power-supply voltage, V_+ . For example, the V_+ power supply can be 5V, whereas the load power-supply voltage is up to +80V. The output voltage range of the OUT terminal, however, is limited by the voltages on the power-supply pin.

ACCURACY VARIATIONS AS A RESULT OF V_{SENSE} AND COMMON-MODE VOLTAGE

The accuracy of the INA193-INA198 current shunt monitors is a function of two main variables: V_{SENSE} ($V_{IN+} - V_{IN-}$) and common-mode voltage, V_{CM} , relative to the supply voltage, V_S . V_{CM} is expressed as $(V_{IN+} + V_{IN-})/2$; however, in practice, V_{CM} is seen as the voltage at V_{IN+} because the voltage drop across V_{SENSE} is usually small.

This section addresses the accuracy of these specific operating regions:

Normal Case 1: $V_{SENSE} \geq 20\text{mV}$, $V_{CM} \geq V_S$

Normal Case 2: $V_{SENSE} \geq 20\text{mV}$, $V_{CM} < V_S$

Low V_{SENSE} Case 1: $V_{SENSE} < 20\text{mV}$, $-16\text{V} \leq V_{CM} < 0$

Low V_{SENSE} Case 2: $V_{SENSE} < 20\text{mV}$, $0\text{V} \leq V_{CM} \leq V_S$

Low V_{SENSE} Case 3: $V_{SENSE} < 20\text{mV}$, $V_S < V_{CM} \leq 80\text{V}$

Normal Case 1: $V_{SENSE} \geq 20\text{mV}$, $V_{CM} \geq V_S$

This region of operation provides the highest accuracy. Here, the input offset voltage is characterized and measured using a two-step method. First, the gain is determined by Equation 1.

$$G = \frac{V_{OUT1} - V_{OUT2}}{100\text{mV} - 20\text{mV}}$$

where:

V_{OUT1} = Output Voltage with $V_{SENSE} = 100\text{mV}$

V_{OUT2} = Output Voltage with $V_{SENSE} = 20\text{mV}$ (1)

Then the offset voltage is measured at $V_{SENSE} = 100\text{mV}$ and referred to the input (RTI) of the current shunt monitor, as shown in Equation 2.

$$V_{OS\text{RTI}} (\text{Referred-To-Input}) = \left[\frac{V_{OUT1}}{G} \right] - 100\text{mV} \quad (2)$$

In the Typical Characteristics, the *Output Error vs Common-Mode Voltage* curve (Figure 6) shows the highest accuracy for this region of operation. In this plot, $V_S = 12\text{V}$; for $V_{CM} \geq 12\text{V}$, the output error is at its minimum. This case is also used to create the $V_{SENSE} \geq 20\text{mV}$ output specifications in the Electrical Characteristics table.

Normal Case 2: $V_{SENSE} \geq 20\text{mV}$, $V_{CM} < V_S$

This region of operation has slightly less accuracy than Normal Case 1 as a result of the common-mode operating area in which the part functions, as seen in the *Output Error vs Common-Mode Voltage* curve (Figure 6). As noted, for this graph $V_S = 12\text{V}$; for $V_{CM} < 12\text{V}$, the Output Error increases as V_{CM} becomes less than 12V , with a typical maximum error of 0.005% at the most negative $V_{CM} = -16\text{V}$.

Low V_{SENSE} Case 1:
 $V_{SENSE} < 20\text{mV}$, $-16\text{V} \leq V_{CM} < 0$;
and Low V_{SENSE} Case 3:
 $V_{SENSE} < 20\text{mV}$, $V_S < V_{CM} \leq 80\text{V}$

Although the INA193–INA198 family of devices are not designed for accurate operation in either of these regions, some applications are exposed to these conditions; for example, when monitoring power supplies that are switched on and off while V_S is still applied to the INA193–INA198. It is important to know what the behavior of the devices will be in these regions.

As V_{SENSE} approaches 0mV , in these V_{CM} regions, the device output accuracy degrades. A larger-than-normal offset can appear at the current shunt monitor output with a typical maximum value of $V_{OUT} = 300\text{mV}$ for $V_{SENSE} = 0\text{mV}$. As V_{SENSE} approaches 20mV , V_{OUT} returns to the expected output value with accuracy as specified in the *Electrical Characteristics*. Figure 19 illustrates this effect using the INA195 and INA198 (Gain = 100).

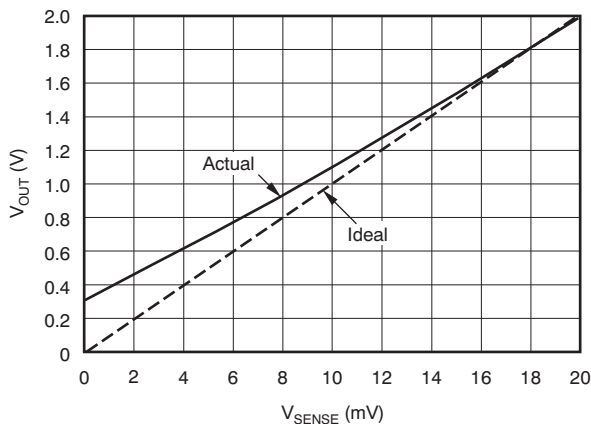
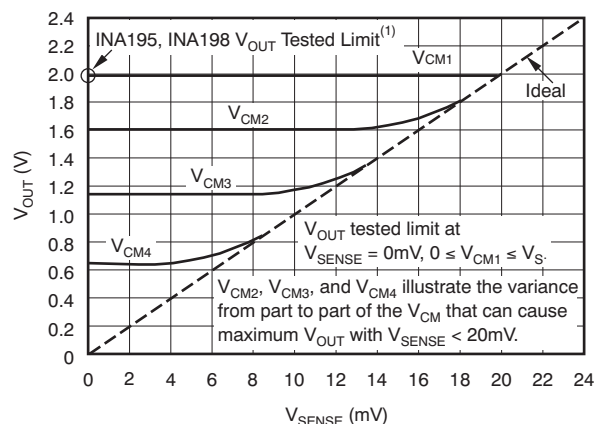

Figure 19. Example for Low V_{SENSE} Cases 1 and 3 (INA195, INA198: Gain = 100)

Low V_{SENSE} Case 2: $V_{SENSE} < 20\text{mV}$, $0\text{V} \leq V_{CM} \leq V_S$

This region of operation is the least accurate for the INA193–INA198 family. To achieve the wide input common-mode voltage range, these devices use two op amp front ends in parallel. One op amp front end operates in the positive input common-mode voltage range, and the other in the negative input region. For this case, neither of these two internal amplifiers dominates and overall loop gain is very low. Within this region, V_{OUT} approaches voltages close to linear operation levels for Normal Case 2. This deviation from linear operation becomes greatest the closer V_{SENSE} approaches 0V . Within this region, as V_{SENSE} approaches 20mV , device operation is closer to that described by Normal Case 2. Figure 20 illustrates this behavior for the INA195. The V_{OUT} maximum peak for this case is tested by maintaining a constant V_S , setting $V_{SENSE} = 0\text{mV}$ and sweeping V_{CM} from 0V to V_S . The exact V_{CM} at which V_{OUT} peaks during this test varies from part to part, but the V_{OUT} maximum peak is tested to be less than the specified V_{OUT} Tested Limit.



(1) INA193, INA196 V_{OUT} Tested Limit = 0.4V . INA194, INA197 V_{OUT} Tested Limit = 1V .

Figure 20. Example for Low V_{SENSE} Case 2 (INA195, INA198: Gain = 100)

SHUTDOWN

Because the INA193-INA198 consume a quiescent current less than 1mA, they can be powered by either the output of logic gates or by transistor switches to supply power. Use a totem-pole output buffer or gate that can provide sufficient drive along with 0.1μF bypass capacitor, preferably ceramic with good high-frequency characteristics. This gate should have a supply voltage of 3V or greater because the INA193-INA198 requires a minimum supply greater than 2.7V. In addition to eliminating quiescent current, this gate also turns off the 10μA bias current present at each of the inputs. An example shutdown circuit is shown in Figure 21.

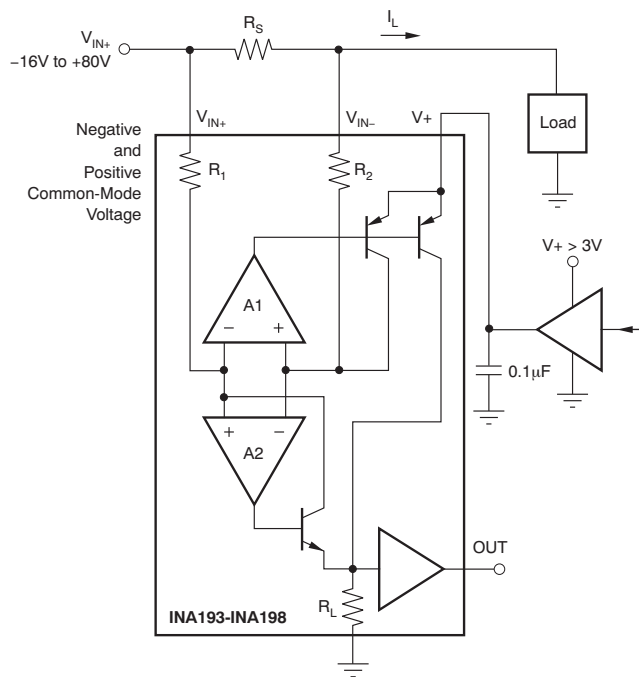

Figure 21. INA193-INA198 Example Shutdown Circuit

SELECTING R_S

The value chosen for the shunt resistor, R_S, depends on the application and is a compromise between small-signal accuracy and maximum permissible

voltage loss in the measurement line. High values of R_S provide better accuracy at lower currents by minimizing the effects of offset, while low values of R_S minimize voltage loss in the supply line. For most applications, best performance is attained with an R_S value that provides a full-scale shunt voltage range of 50mV to 100mV. Maximum input voltage for accurate measurements is 500mV.

TRANSIENT PROTECTION

The -16V to +80V common-mode range of the INA193-INA198 is ideal for withstanding automotive fault conditions ranging from 12V battery reversal up to +80V transients, since no additional protective components are needed up to those levels. In the event that the INA193-INA198 is exposed to transients on the inputs in excess of its ratings, then external transient absorption with semiconductor transient absorbers (zeners or Transzorbs) will be necessary. Use of MOVs or VDRs is not recommended except when they are used in addition to a semiconductor transient absorber. Select the transient absorber such that it will never allow the INA193-INA198 to be exposed to transients greater than +80V (that is, allow for transient absorber tolerance, as well as additional voltage due to transient absorber dynamic impedance). Despite the use of internal zener-type ESD protection, the INA193-INA198 does not lend itself to using external resistors in series with the inputs because the internal gain resistors can vary up to ±30%. (If gain accuracy is not important, then resistors can be added in series with the INA193-INA198 inputs with two equal resistors on each input.)

OUTPUT VOLTAGE RANGE

The output of the INA193-INA198 is accurate within the output voltage swing range set by the power-supply pin, V+. This is best illustrated when using the INA195 or INA198 (which are both versions using a gain of 100), where a 100mV full-scale input from the shunt resistor requires an output voltage swing of +10V, and a power-supply voltage sufficient to achieve +10V on the output.

RFI/EMI

Attention to good layout practices is always recommended. Keep traces short and, when possible, use a printed circuit board (PCB) ground plane with surface-mount components placed as close to the device pins as possible. Small ceramic capacitors placed directly across amplifier inputs can reduce RFI/EMI sensitivity. PCB layout should locate the amplifier as far away as possible from RFI sources. Sources can include other components in the same system as the amplifier itself, such as inductors (particularly switched inductors handling a lot of current and at high frequencies). RFI can generally be identified as a variation in offset voltage or dc signal levels with changes in the interfering RF signal. If the amplifier cannot be located away from sources of radiation, shielding may be needed. Twisting wire input leads makes them more resistant to RF fields. The difference in input pin location of the INA193-INA195 versus the INA196-INA198 may provide different EMI performance.

INPUT FILTERING

An obvious and straightforward location for filtering is at the output of the INA193-INA198; however, this location negates the advantage of the low output impedance of the internal buffer. The only other option for filtering is at the input pins of the INA193-INA198, which is complicated by the internal $5\text{k}\Omega + 30\%$ input impedance; this is illustrated in Figure 22. Using the lowest possible resistor values minimizes both the initial shift in gain and effects of tolerance. The effect on initial gain is given by Equation 3:

$$\text{GainError}\% = 100 - \left[\frac{5\text{k}\Omega}{5\text{k}\Omega + R_{\text{FILT}}} \right] \times 100 \quad (3)$$

Total effect on gain error can be calculated by replacing the $5\text{k}\Omega$ term with $5\text{k}\Omega - 30\%$, (or $3.5\text{k}\Omega$) or $5\text{k}\Omega + 30\%$ (or $6.5\text{k}\Omega$). The tolerance extremes of R_{FILT} can also be inserted into the equation. If a pair of 100Ω 1% resistors are used on the inputs, the initial gain error will be approximately 2%. Worst-case tolerance conditions will always occur at the lower excursion of the internal $5\text{k}\Omega$ resistor ($3.5\text{k}\Omega$), and the higher excursion of $R_{\text{FILT}} = 3\%$ in this case.

Note that the specified accuracy of the INA193-INA198 must then be combined in addition to these tolerances. While this discussion treated accuracy worst-case conditions by combining the extremes of the resistor values, it is appropriate to use geometric mean or root sum square calculations to total the effects of accuracy variations.

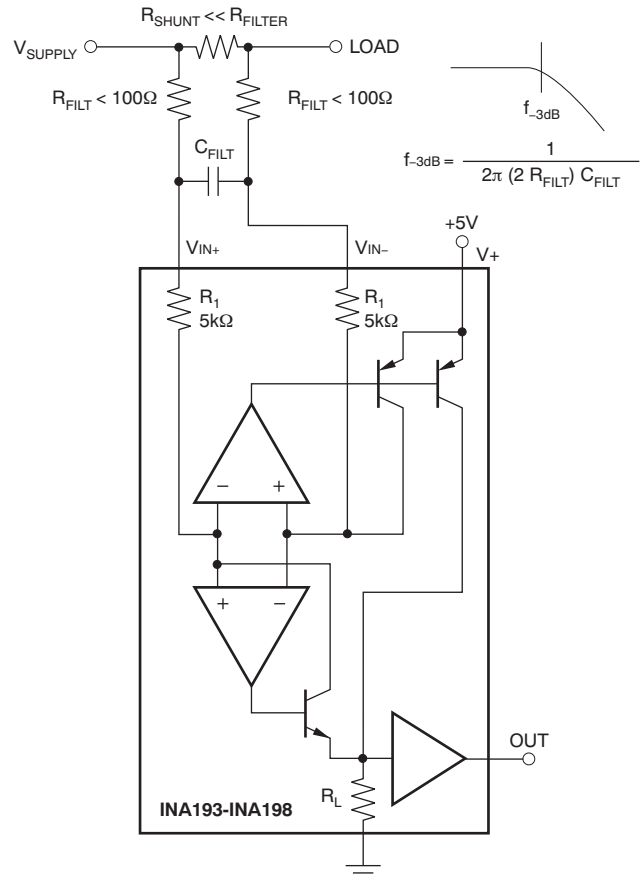
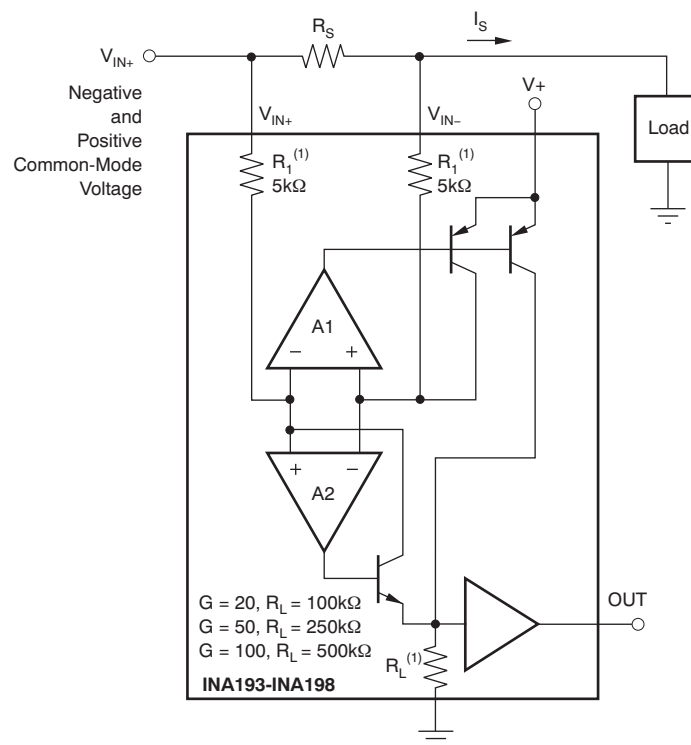

Figure 22. Input Filter (Gain Error – 1.5% to –2.2%)

INSIDE THE INA193-INA198

The INA193-INA198 uses a new, unique internal circuit topology that provides common-mode range extending from -16V to $+80\text{V}$ while operating from a single power supply. The common-mode rejection in a classic instrumentation amplifier approach is limited by the requirement for accurate resistor matching. By converting the induced input voltage to a current, the INA193-INA198 provides common-mode rejection that is no longer a function of closely matched resistor values, providing the enhanced performance necessary for such a wide common-mode range. A simplified diagram (shown in Figure 23) shows the basic circuit function. When the common-mode voltage is positive, amplifier A2 is active.

The differential input voltage, $(V_{IN+}) - (V_{IN-})$ applied across R_S , is converted to a current through a resistor. This current is converted back to a voltage through R_L , and then amplified by the output buffer amplifier. When the common-mode voltage is negative, amplifier A1 is active. The differential input voltage, $(V_{IN+}) - (V_{IN-})$ applied across R_S , is converted to a current through a resistor. This current is sourced from a precision current mirror whose output is directed into R_L converting the signal back into a voltage and amplified by the output buffer amplifier. Patent-pending circuit architecture ensures smooth device operation, even during the transition period where both amplifiers A1 and A2 are active.



(1) Nominal resistor values are shown. $\pm 15\%$ variation is possible. Resistor ratios are matched to $\pm 1\%$.

Figure 23. INA193-INA198 Simplified Circuit Diagram

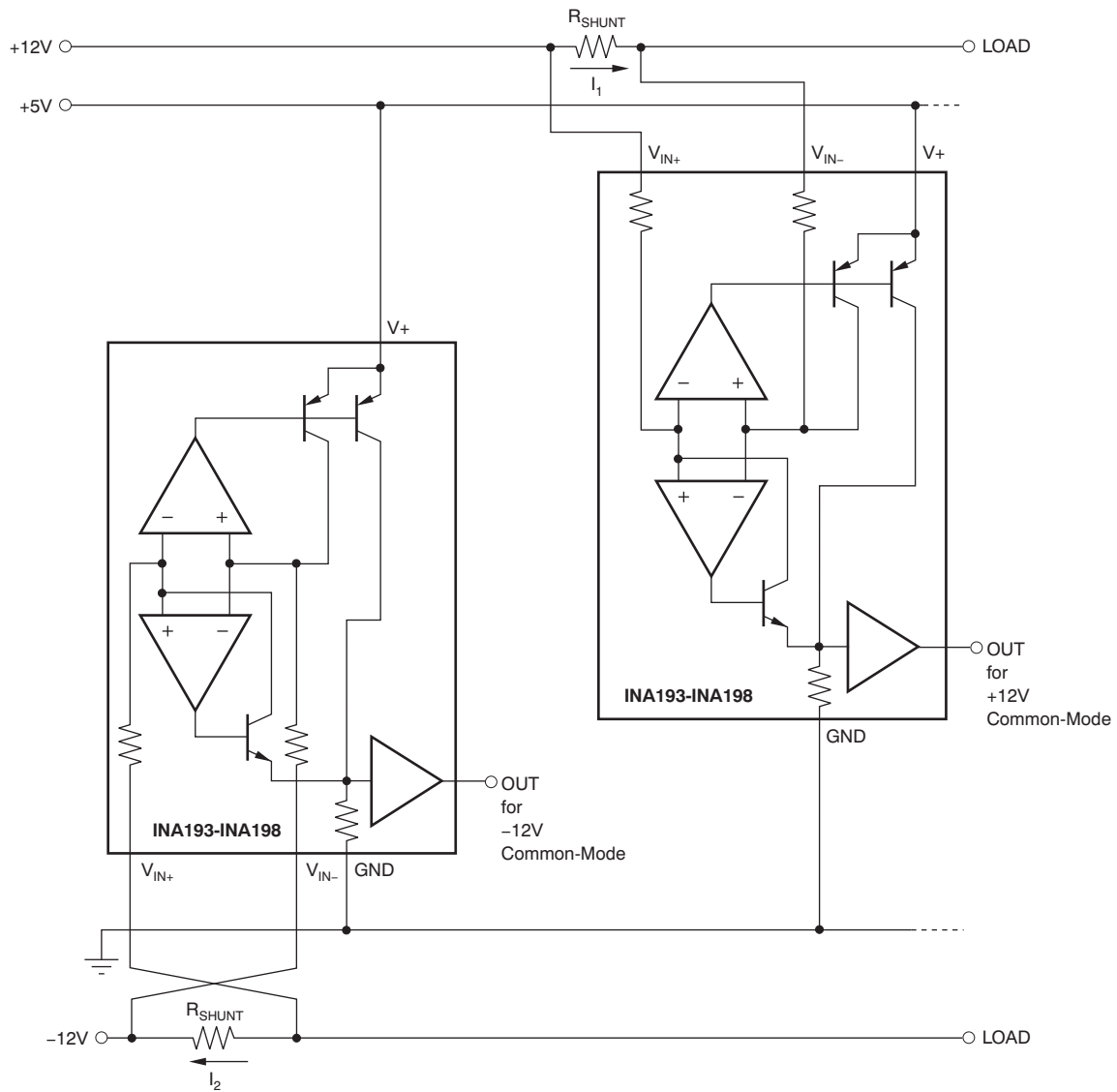

Figure 24. Monitor Bipolar Output Power-Supply Current

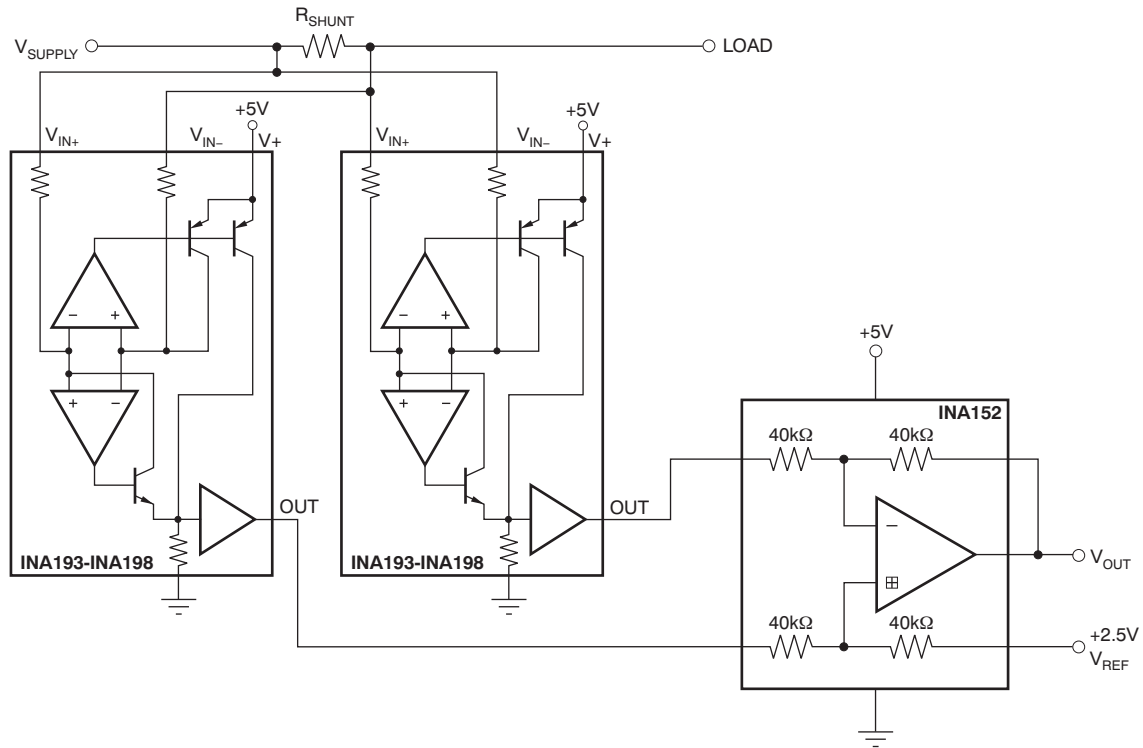

Figure 25. Bi-Directional Current Monitoring

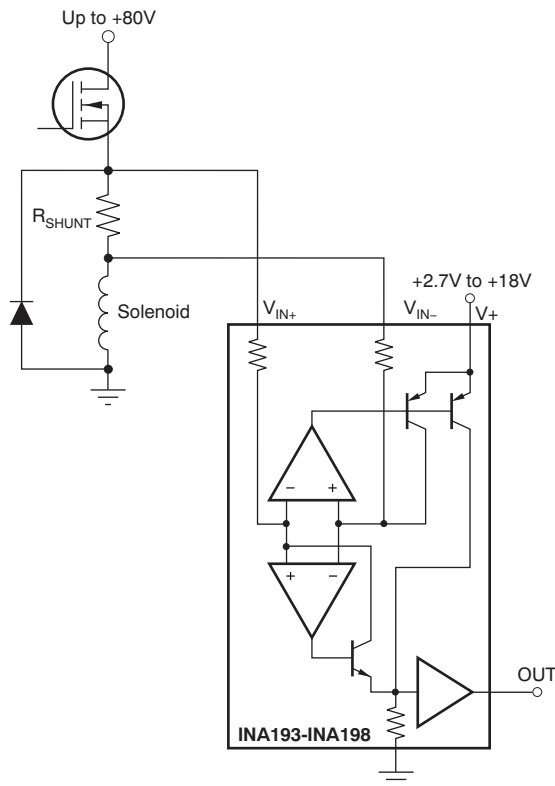

Figure 26. Inductive Current Monitor Including Flyback

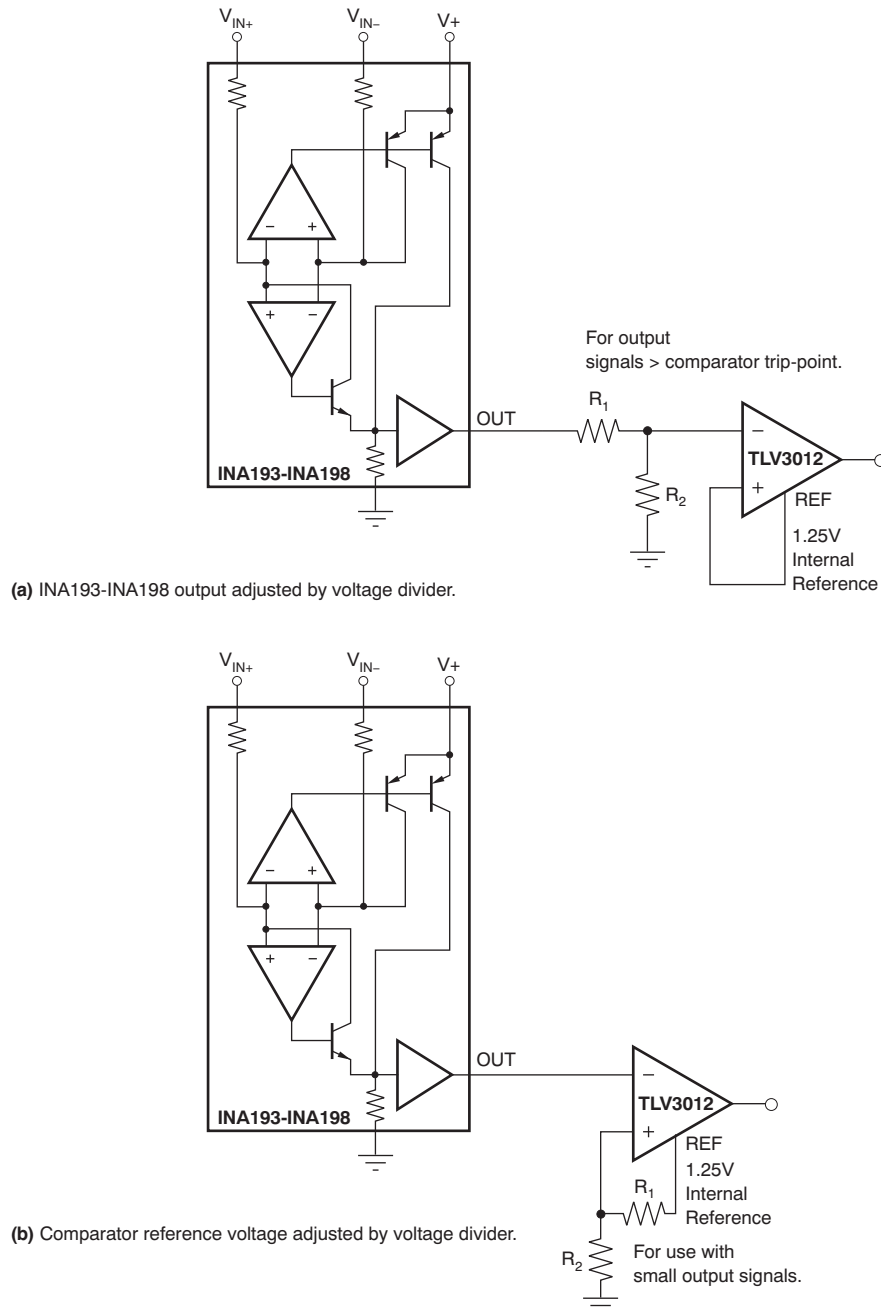

Figure 27. INA193-INA198 With Comparator

REVISION HISTORY

NOTE: Page numbers for previous revisions may differ from page numbers in the current version.

Changes from Revision E (August 2006) to Revision F	Page
• Updated document format to current standards	1
• Added test conditions to Output, <i>Total Output Error</i> parameter in Electrical Characteristics: $V_S = +12V$	3

PACKAGING INFORMATION

Orderable Device	Status (1)	Package Type	Package Drawing	Pins	Package Qty	Eco Plan (2)	Lead/Ball Finish	MSL Peak Temp (3)	Op Temp (°C)	Device Marking (4/5)	Samples
INA193AIDBVR	ACTIVE	SOT-23	DBV	5	3000	Green (RoHS & no Sb/Br)	CU NIPDAU	Level-2-260C-1 YEAR	-55 to 150	BJJ	Samples
INA193AIDBVRG4	ACTIVE	SOT-23	DBV	5	3000	Green (RoHS & no Sb/Br)	CU NIPDAU	Level-2-260C-1 YEAR	-55 to 150	BJJ	Samples
INA193AIDBVT	ACTIVE	SOT-23	DBV	5	250	Green (RoHS & no Sb/Br)	CU NIPDAU	Level-2-260C-1 YEAR	-55 to 150	BJJ	Samples
INA193AIDBVTG4	ACTIVE	SOT-23	DBV	5	250	Green (RoHS & no Sb/Br)	CU NIPDAU	Level-2-260C-1 YEAR	-55 to 150	BJJ	Samples
INA194AIDBVR	ACTIVE	SOT-23	DBV	5	3000	Green (RoHS & no Sb/Br)	CU NIPDAU	Level-2-260C-1 YEAR	-55 to 150	BJI	Samples
INA194AIDBVRG4	ACTIVE	SOT-23	DBV	5	3000	Green (RoHS & no Sb/Br)	CU NIPDAU	Level-2-260C-1 YEAR	-55 to 150	BJI	Samples
INA194AIDBVT	ACTIVE	SOT-23	DBV	5	250	Green (RoHS & no Sb/Br)	CU NIPDAU	Level-2-260C-1 YEAR	-55 to 150	BJI	Samples
INA194AIDBVTG4	ACTIVE	SOT-23	DBV	5	250	Green (RoHS & no Sb/Br)	CU NIPDAU	Level-2-260C-1 YEAR	-55 to 150	BJI	Samples
INA195AIDBVR	ACTIVE	SOT-23	DBV	5	3000	Green (RoHS & no Sb/Br)	CU NIPDAU	Level-2-260C-1 YEAR	-55 to 150	BJK	Samples
INA195AIDBVRG4	ACTIVE	SOT-23	DBV	5	3000	Green (RoHS & no Sb/Br)	CU NIPDAU	Level-2-260C-1 YEAR	-55 to 150	BJK	Samples
INA195AIDBVT	ACTIVE	SOT-23	DBV	5	250	Green (RoHS & no Sb/Br)	CU NIPDAU	Level-2-260C-1 YEAR	-55 to 150	BJK	Samples
INA195AIDBVTG4	ACTIVE	SOT-23	DBV	5	250	Green (RoHS & no Sb/Br)	CU NIPDAU	Level-2-260C-1 YEAR	-55 to 150	BJK	Samples
INA196AIDBVR	ACTIVE	SOT-23	DBV	5	3000	Green (RoHS & no Sb/Br)	CU NIPDAU	Level-2-260C-1 YEAR	-55 to 150	BJE	Samples
INA196AIDBVRG4	ACTIVE	SOT-23	DBV	5	3000	Green (RoHS & no Sb/Br)	CU NIPDAU	Level-2-260C-1 YEAR	-55 to 150	BJE	Samples
INA196AIDBVT	ACTIVE	SOT-23	DBV	5	250	Green (RoHS & no Sb/Br)	CU NIPDAU	Level-2-260C-1 YEAR	-55 to 150	BJE	Samples
INA196AIDBVTG4	ACTIVE	SOT-23	DBV	5	250	Green (RoHS & no Sb/Br)	CU NIPDAU	Level-2-260C-1 YEAR	-55 to 150	BJE	Samples
INA197AIDBVR	ACTIVE	SOT-23	DBV	5	3000	Green (RoHS & no Sb/Br)	CU NIPDAU	Level-2-260C-1 YEAR	-55 to 150	BJH	Samples

Orderable Device	Status (1)	Package Type	Package Drawing	Pins	Package Qty	Eco Plan (2)	Lead/Ball Finish	MSL Peak Temp (3)	Op Temp (°C)	Device Marking (4/5)	Samples
INA197AIDBVRG4	ACTIVE	SOT-23	DBV	5	3000	Green (RoHS & no Sb/Br)	CU NIPDAU	Level-2-260C-1 YEAR	-55 to 150	BJH	Samples
INA197AIDBVT	ACTIVE	SOT-23	DBV	5	250	Green (RoHS & no Sb/Br)	CU NIPDAU	Level-2-260C-1 YEAR	-55 to 150	BJH	Samples
INA197AIDBVTG4	ACTIVE	SOT-23	DBV	5	250	Green (RoHS & no Sb/Br)	CU NIPDAU	Level-2-260C-1 YEAR	-55 to 150	BJH	Samples
INA198AIDBVR	ACTIVE	SOT-23	DBV	5	3000	Green (RoHS & no Sb/Br)	CU NIPDAU	Level-2-260C-1 YEAR	-55 to 150	BJL	Samples
INA198AIDBVRG4	ACTIVE	SOT-23	DBV	5	3000	Green (RoHS & no Sb/Br)	CU NIPDAU	Level-2-260C-1 YEAR	-55 to 150	BJL	Samples
INA198AIDBVT	ACTIVE	SOT-23	DBV	5	250	Green (RoHS & no Sb/Br)	CU NIPDAU	Level-2-260C-1 YEAR	-55 to 150	BJL	Samples
INA198AIDBVTG4	ACTIVE	SOT-23	DBV	5	250	Green (RoHS & no Sb/Br)	CU NIPDAU	Level-2-260C-1 YEAR	-55 to 150	BJL	Samples

(1) The marketing status values are defined as follows:

ACTIVE: Product device recommended for new designs.

LIFEBUY: TI has announced that the device will be discontinued, and a lifetime-buy period is in effect.

NRND: Not recommended for new designs. Device is in production to support existing customers, but TI does not recommend using this part in a new design.

PREVIEW: Device has been announced but is not in production. Samples may or may not be available.

OBSELETE: TI has discontinued the production of the device.

(2) Eco Plan - The planned eco-friendly classification: Pb-Free (RoHS), Pb-Free (RoHS Exempt), or Green (RoHS & no Sb/Br) - please check <http://www.ti.com/productcontent> for the latest availability information and additional product content details.

TBD: The Pb-Free/Green conversion plan has not been defined.

Pb-Free (RoHS): TI's terms "Lead-Free" or "Pb-Free" mean semiconductor products that are compatible with the current RoHS requirements for all 6 substances, including the requirement that lead not exceed 0.1% by weight in homogeneous materials. Where designed to be soldered at high temperatures, TI Pb-Free products are suitable for use in specified lead-free processes.

Pb-Free (RoHS Exempt): This component has a RoHS exemption for either 1) lead-based flip-chip solder bumps used between the die and package, or 2) lead-based die adhesive used between the die and leadframe. The component is otherwise considered Pb-Free (RoHS compatible) as defined above.

Green (RoHS & no Sb/Br): TI defines "Green" to mean Pb-Free (RoHS compatible), and free of Bromine (Br) and Antimony (Sb) based flame retardants (Br or Sb do not exceed 0.1% by weight in homogeneous material)

(3) MSL, Peak Temp. -- The Moisture Sensitivity Level rating according to the JEDEC industry standard classifications, and peak solder temperature.

(4) There may be additional marking, which relates to the logo, the lot trace code information, or the environmental category on the device.

(5) Multiple Device Markings will be inside parentheses. Only one Device Marking contained in parentheses and separated by a "-" will appear on a device. If a line is indented then it is a continuation of the previous line and the two combined represent the entire Device Marking for that device.

Important Information and Disclaimer: The information provided on this page represents TI's knowledge and belief as of the date that it is provided. TI bases its knowledge and belief on information provided by third parties, and makes no representation or warranty as to the accuracy of such information. Efforts are underway to better integrate information from third parties. TI has taken and continues to take reasonable steps to provide representative and accurate information but may not have conducted destructive testing or chemical analysis on incoming materials and chemicals. TI and TI suppliers consider certain information to be proprietary, and thus CAS numbers and other limited information may not be available for release.

In no event shall TI's liability arising out of such information exceed the total purchase price of the TI part(s) at issue in this document sold by TI to Customer on an annual basis.

TAPE AND REEL INFORMATION



QUADRANT ASSIGNMENTS FOR PIN 1 ORIENTATION IN TAPE



*All dimensions are nominal

Device	Package Type	Package Drawing	Pins	SPQ	Reel Diameter (mm)	Reel Width W1 (mm)	A0 (mm)	B0 (mm)	K0 (mm)	P1 (mm)	W (mm)	Pin1 Quadrant
INA193AIDBVR	SOT-23	DBV	5	3000	178.0	9.0	3.23	3.17	1.37	4.0	8.0	Q3
INA193AIDBVT	SOT-23	DBV	5	250	178.0	9.0	3.3	3.2	1.4	4.0	8.0	Q3
INA194AIDBVR	SOT-23	DBV	5	3000	178.0	9.0	3.23	3.17	1.37	4.0	8.0	Q3
INA194AIDBVT	SOT-23	DBV	5	250	178.0	9.0	3.3	3.2	1.4	4.0	8.0	Q3
INA195AIDBVR	SOT-23	DBV	5	3000	178.0	9.0	3.3	3.2	1.4	4.0	8.0	Q3
INA195AIDBVT	SOT-23	DBV	5	250	178.0	9.0	3.3	3.2	1.4	4.0	8.0	Q3
INA196AIDBVR	SOT-23	DBV	5	3000	178.0	9.0	3.3	3.2	1.4	4.0	8.0	Q3
INA196AIDBVT	SOT-23	DBV	5	250	178.0	9.0	3.3	3.2	1.4	4.0	8.0	Q3
INA197AIDBVR	SOT-23	DBV	5	3000	178.0	9.0	3.3	3.2	1.4	4.0	8.0	Q3
INA197AIDBVT	SOT-23	DBV	5	250	178.0	9.0	3.3	3.2	1.4	4.0	8.0	Q3
INA198AIDBVR	SOT-23	DBV	5	3000	178.0	9.0	3.3	3.2	1.4	4.0	8.0	Q3
INA198AIDBVT	SOT-23	DBV	5	250	178.0	9.0	3.23	3.17	1.37	4.0	8.0	Q3

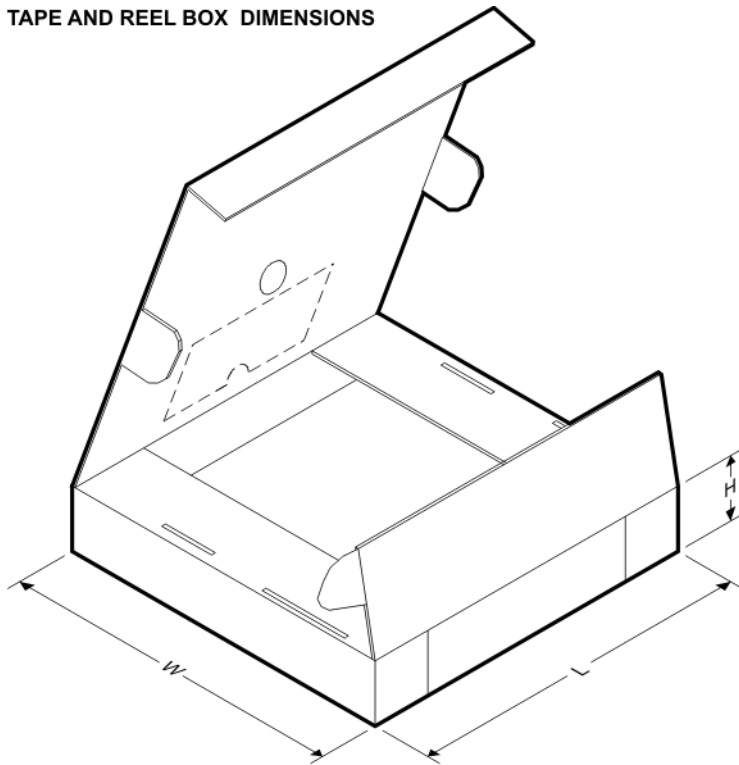
TAPE AND REEL BOX DIMENSIONS

*All dimensions are nominal

Device	Package Type	Package Drawing	Pins	SPQ	Length (mm)	Width (mm)	Height (mm)
INA193AIDBVR	SOT-23	DBV	5	3000	180.0	180.0	18.0
INA193AIDBVT	SOT-23	DBV	5	250	180.0	180.0	18.0
INA194AIDBVR	SOT-23	DBV	5	3000	180.0	180.0	18.0
INA194AIDBVT	SOT-23	DBV	5	250	180.0	180.0	18.0
INA195AIDBVR	SOT-23	DBV	5	3000	180.0	180.0	18.0
INA195AIDBVT	SOT-23	DBV	5	250	180.0	180.0	18.0
INA196AIDBVR	SOT-23	DBV	5	3000	180.0	180.0	18.0
INA196AIDBVT	SOT-23	DBV	5	250	180.0	180.0	18.0
INA197AIDBVR	SOT-23	DBV	5	3000	180.0	180.0	18.0
INA197AIDBVT	SOT-23	DBV	5	250	180.0	180.0	18.0
INA198AIDBVR	SOT-23	DBV	5	3000	180.0	180.0	18.0
INA198AIDBVT	SOT-23	DBV	5	250	180.0	180.0	18.0

DBV (R-PDSO-G5)

PLASTIC SMALL-OUTLINE PACKAGE

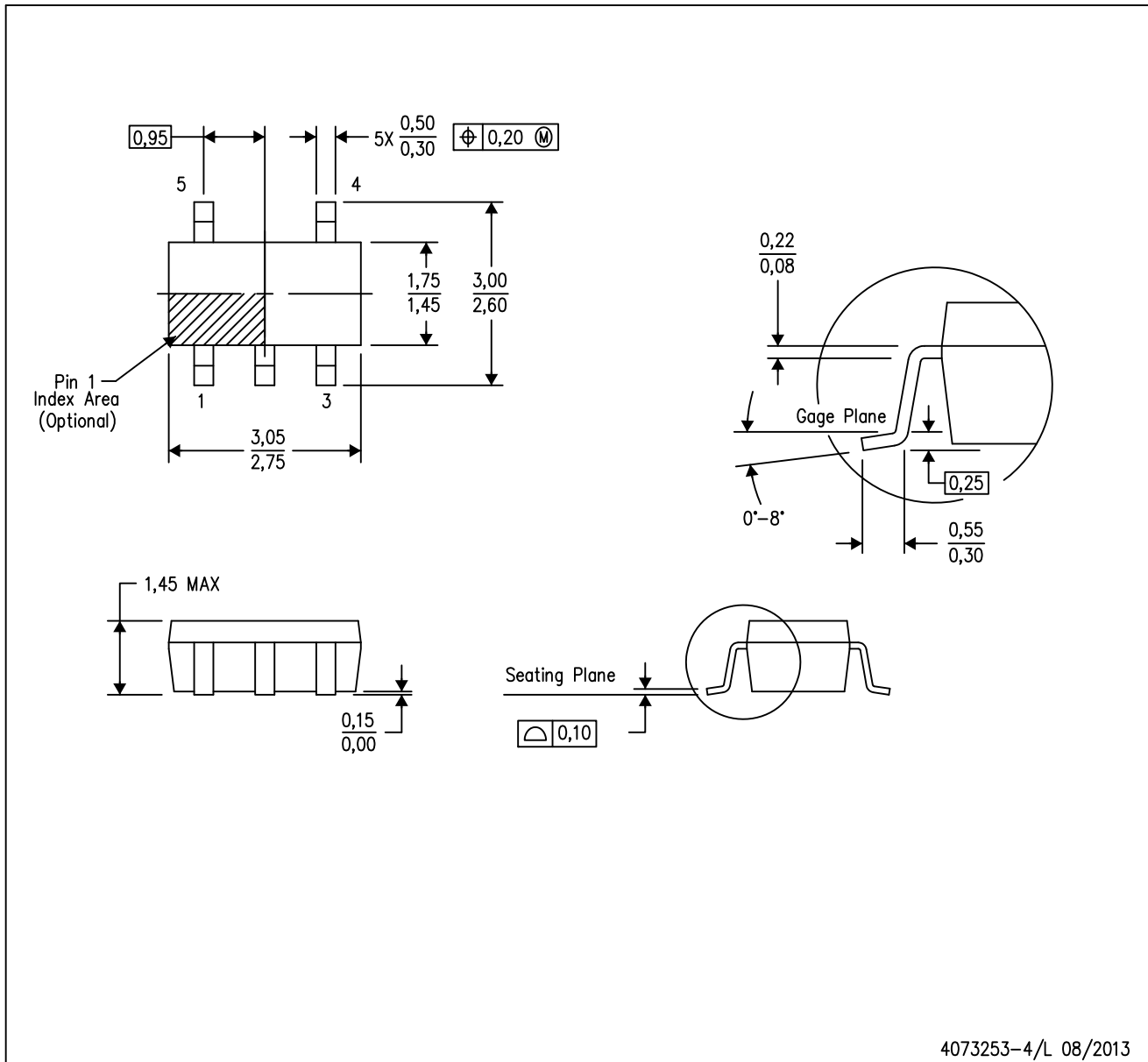

4073253-4/L 08/2013

- NOTES:
- A. All linear dimensions are in millimeters.
 - B. This drawing is subject to change without notice.
 - C. Body dimensions do not include mold flash or protrusion. Mold flash and protrusion shall not exceed 0.15 per side.
 - D. Falls within JEDEC MO-178 Variation AA.

DBV (R-PDSO-G5)

PLASTIC SMALL OUTLINE

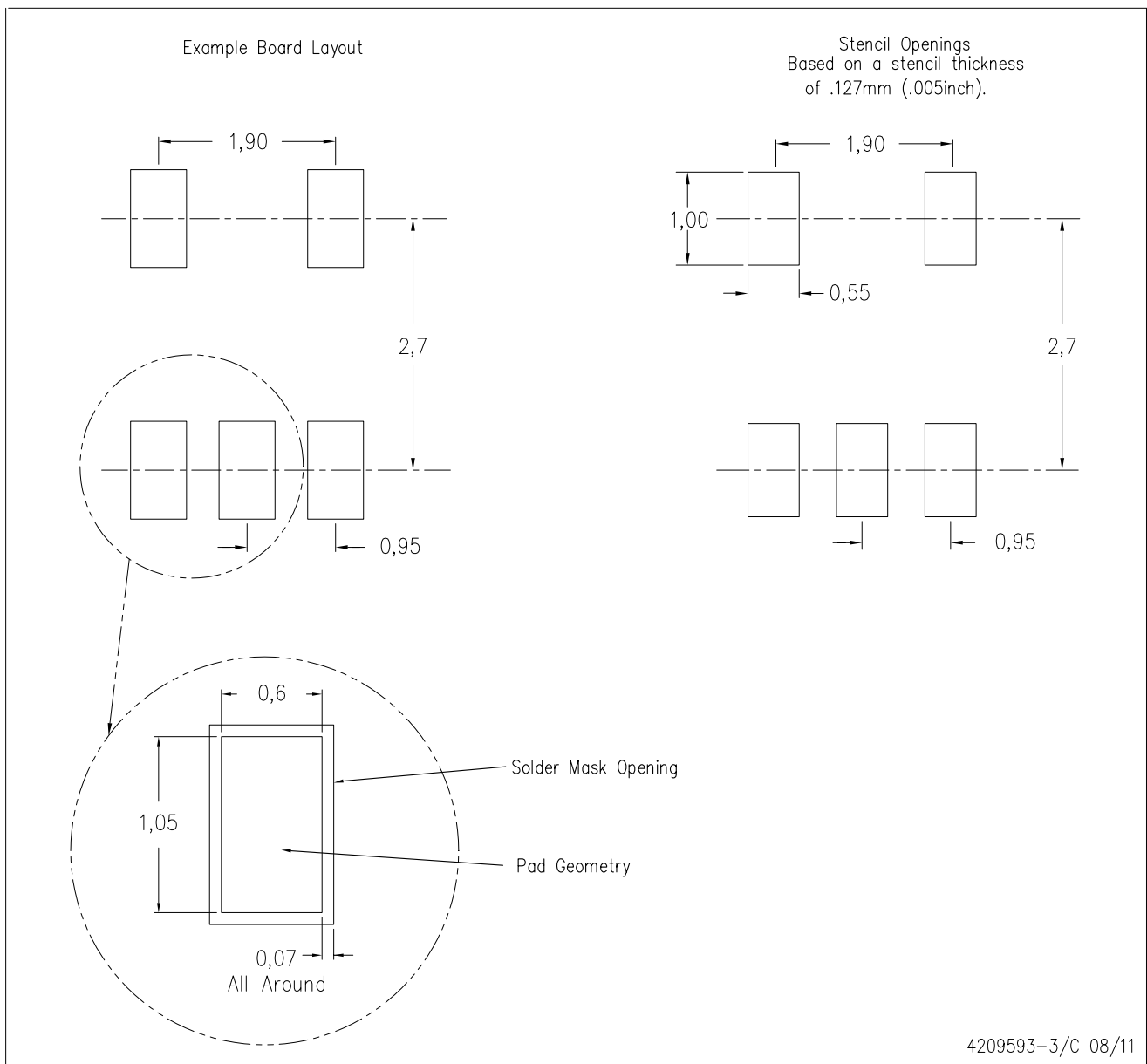

4209593-3/C 08/11

- NOTES:
- A. All linear dimensions are in millimeters.
 - B. This drawing is subject to change without notice.
 - C. Customers should place a note on the circuit board fabrication drawing not to alter the center solder mask defined pad.
 - D. Publication IPC-7351 is recommended for alternate designs.
 - E. Laser cutting apertures with trapezoidal walls and also rounding corners will offer better paste release. Customers should contact their board assembly site for stencil design recommendations. Example stencil design based on a 50% volumetric metal load solder paste. Refer to IPC-7525 for other stencil recommendations.

IMPORTANT NOTICE

Texas Instruments Incorporated and its subsidiaries (TI) reserve the right to make corrections, enhancements, improvements and other changes to its semiconductor products and services per JESD46, latest issue, and to discontinue any product or service per JESD48, latest issue. Buyers should obtain the latest relevant information before placing orders and should verify that such information is current and complete. All semiconductor products (also referred to herein as "components") are sold subject to TI's terms and conditions of sale supplied at the time of order acknowledgment.

TI warrants performance of its components to the specifications applicable at the time of sale, in accordance with the warranty in TI's terms and conditions of sale of semiconductor products. Testing and other quality control techniques are used to the extent TI deems necessary to support this warranty. Except where mandated by applicable law, testing of all parameters of each component is not necessarily performed.

TI assumes no liability for applications assistance or the design of Buyers' products. Buyers are responsible for their products and applications using TI components. To minimize the risks associated with Buyers' products and applications, Buyers should provide adequate design and operating safeguards.

TI does not warrant or represent that any license, either express or implied, is granted under any patent right, copyright, mask work right, or other intellectual property right relating to any combination, machine, or process in which TI components or services are used. Information published by TI regarding third-party products or services does not constitute a license to use such products or services or a warranty or endorsement thereof. Use of such information may require a license from a third party under the patents or other intellectual property of the third party, or a license from TI under the patents or other intellectual property of TI.

Reproduction of significant portions of TI information in TI data books or data sheets is permissible only if reproduction is without alteration and is accompanied by all associated warranties, conditions, limitations, and notices. TI is not responsible or liable for such altered documentation. Information of third parties may be subject to additional restrictions.

Resale of TI components or services with statements different from or beyond the parameters stated by TI for that component or service voids all express and any implied warranties for the associated TI component or service and is an unfair and deceptive business practice. TI is not responsible or liable for any such statements.

Buyer acknowledges and agrees that it is solely responsible for compliance with all legal, regulatory and safety-related requirements concerning its products, and any use of TI components in its applications, notwithstanding any applications-related information or support that may be provided by TI. Buyer represents and agrees that it has all the necessary expertise to create and implement safeguards which anticipate dangerous consequences of failures, monitor failures and their consequences, lessen the likelihood of failures that might cause harm and take appropriate remedial actions. Buyer will fully indemnify TI and its representatives against any damages arising out of the use of any TI components in safety-critical applications.

In some cases, TI components may be promoted specifically to facilitate safety-related applications. With such components, TI's goal is to help enable customers to design and create their own end-product solutions that meet applicable functional safety standards and requirements. Nonetheless, such components are subject to these terms.

No TI components are authorized for use in FDA Class III (or similar life-critical medical equipment) unless authorized officers of the parties have executed a special agreement specifically governing such use.

Only those TI components which TI has specifically designated as military grade or "enhanced plastic" are designed and intended for use in military/aerospace applications or environments. Buyer acknowledges and agrees that any military or aerospace use of TI components which have **not** been so designated is solely at the Buyer's risk, and that Buyer is solely responsible for compliance with all legal and regulatory requirements in connection with such use.

TI has specifically designated certain components as meeting ISO/TS16949 requirements, mainly for automotive use. In any case of use of non-designated products, TI will not be responsible for any failure to meet ISO/TS16949.

Products

Audio	www.ti.com/audio
Amplifiers	amplifier.ti.com
Data Converters	dataconverter.ti.com
DLP® Products	www.dlp.com
DSP	dsp.ti.com
Clocks and Timers	www.ti.com/clocks
Interface	interface.ti.com
Logic	logic.ti.com
Power Mgmt	power.ti.com
Microcontrollers	microcontroller.ti.com
RFID	www.ti-rfid.com
OMAP Applications Processors	www.ti.com/omap
Wireless Connectivity	www.ti.com/wirelessconnectivity

Applications

Automotive and Transportation	www.ti.com/automotive
Communications and Telecom	www.ti.com/communications
Computers and Peripherals	www.ti.com/computers
Consumer Electronics	www.ti.com/consumer-apps
Energy and Lighting	www.ti.com/energy
Industrial	www.ti.com/industrial
Medical	www.ti.com/medical
Security	www.ti.com/security
Space, Avionics and Defense	www.ti.com/space-avionics-defense
Video and Imaging	www.ti.com/video

TI E2E Community

e2e.ti.com