

- Complete PWM Power-Control Function
- Totem-Pole Outputs for 200-mA Sink or Source Current
- Output Control Selects Parallel or Push-Pull Operation
- Internal Circuitry Prohibits Double Pulse at Either Output
- Variable Dead-Time Provides Control Over Total Range
- Internal Regulator Provides a Stable 5-V Reference Supply, Trimmed to 1% Tolerance
- On-Board Output Current-Limiting Protection
- Undervoltage Lockout for Low- V_{CC} Conditions
- Separate Power and Signal Grounds

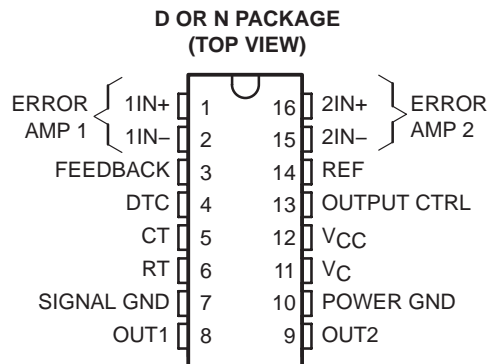

description/ordering information

The TL598 incorporates all the functions required in the construction of pulse-width-modulated (PWM) controlled systems on a single chip. Designed primarily for power-supply control, the TL598 provides the systems engineer with the flexibility to tailor the power-supply control circuits to a specific application.

The TL598 contains two error amplifiers, an internal oscillator (externally adjustable), a dead-time control (DTC) comparator, a pulse-steering flip-flop, a 5-V precision reference, undervoltage lockout control, and output control circuits. Two totem-pole outputs provide exceptional rise- and fall-time performance for power FET control. The outputs share a common source supply and common power ground terminals, which allow system designers to eliminate errors caused by high current-induced voltage drops and common-mode noise.

The error amplifier has a common-mode voltage range of 0 V to $V_{CC} - 2$ V. The DTC comparator has a fixed offset that prevents overlap of the outputs during push-pull operation. A synchronous multiple supply operation can be achieved by connecting RT to the reference output and providing a sawtooth input to CT.

The TL598 device provides an output control function to select either push-pull or parallel operation. Circuit architecture prevents either output from being pulsed twice during push-pull operation. The output frequency

for push-pull applications is one-half the oscillator frequency $\left(f_o = \frac{1}{2 RT CT}\right)$. For single-ended applications:

$$f_o = \frac{1}{RT CT}$$

ORDERING INFORMATION

T _A	PACKAGE†		ORDERABLE PART NUMBER	TOP-SIDE MARKING
0°C to 70°C	PDIP (N)	Tube of 25	TL598CN	TL598CN
	SOIC (D)	Tube of 40	TL598CD	TL598C
		Reel of 2500	TL598CDR	

† Package drawings, standard packing quantities, thermal data, symbolization, and PCB design guidelines are available at www.ti.com/sc/package.



Please be aware that an important notice concerning availability, standard warranty, and use in critical applications of Texas Instruments semiconductor products and disclaimers thereto appears at the end of this data sheet.

PRODUCTION DATA information is current as of publication date. Products conform to specifications per the terms of Texas Instruments standard warranty. Production processing does not necessarily include testing of all parameters.

**TEXAS
INSTRUMENTS**

POST OFFICE BOX 655303 • DALLAS, TEXAS 75265

Copyright © 2003, Texas Instruments Incorporated

TL598 PULSE-WIDTH-MODULATION CONTROL CIRCUITS

SLVS053D – FEBRUARY 1988 – REVISED NOVEMBER 2003

FUNCTION TABLE

INPUT/OUTPUT CTRL	OUTPUT FUNCTION
$V_I = \text{GND}$	Single-ended or parallel output
$V_I = \text{REF}$	Normal push-pull operation

functional block diagram

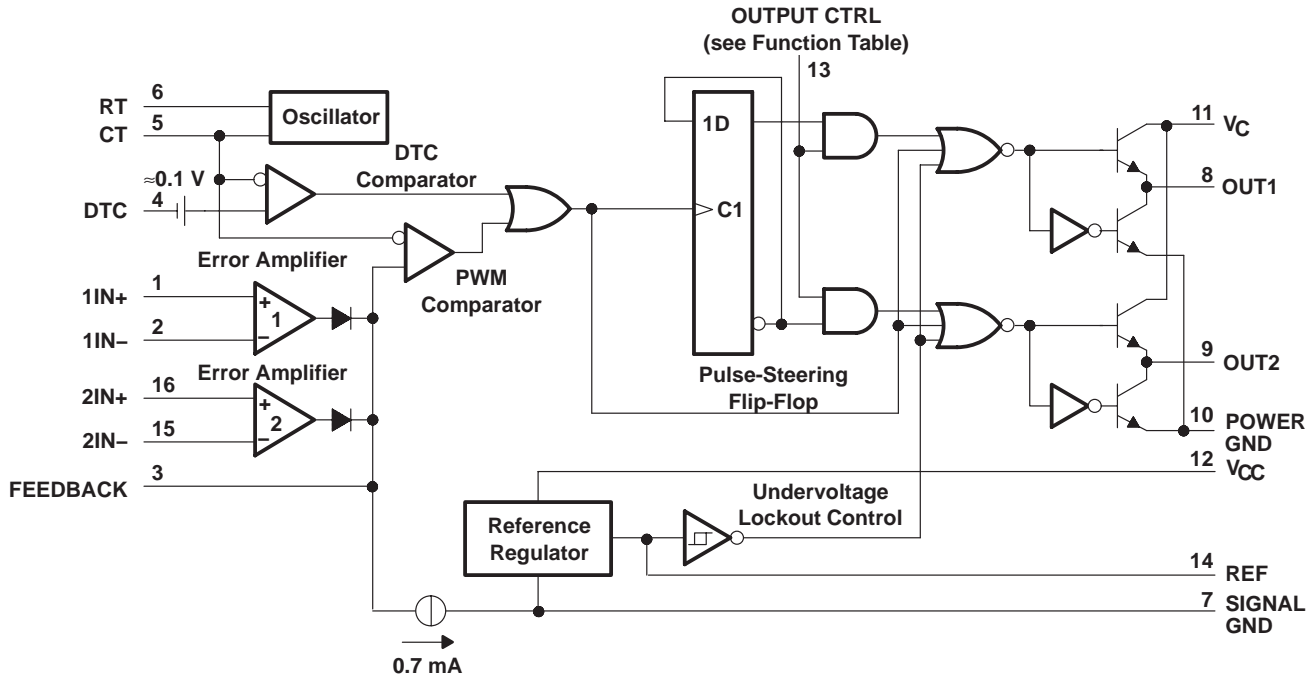

absolute maximum ratings over operating free-air temperature range (unless otherwise noted)†

Supply voltage, V_{CC} (see Note 1)	41 V
Amplifier input voltage, V_I	$V_{CC} + 0.3 \text{ V}$
Collector voltage	41 V
Output current (each output), sink or source, I_O	250 mA
Package thermal impedance, θ_{JA} (see Notes 2 and 3): D package	73°C/W
N package	67°C/W
Operating virtual junction temperature, T_J	150°C
Storage temperature range, T_{stg}	-65°C to 150°C

† Stresses beyond those listed under "absolute maximum ratings" may cause permanent damage to the device. These are stress ratings only, and functional operation of the device at these or any other conditions beyond those indicated under "recommended operating conditions" is not implied. Exposure to absolute-maximum-rated conditions for extended periods may affect device reliability.

- NOTES:
1. All voltage values, except differential voltages, are with respect to the signal ground terminal.
 2. Maximum power dissipation is a function of $T_J(\text{max})$, θ_{JA} , and T_A . The maximum allowable power dissipation at any allowable ambient temperature is $P_D = (T_J(\text{max}) - T_A)/\theta_{JA}$. Operating at the absolute maximum T_J of 150°C can impact reliability.
 3. The package thermal impedance is calculated in accordance with JESD 51-7.

recommended operating conditions

	MIN	MAX	UNIT
V _{CC} Supply voltage	7	40	V
V _I Amplifier input voltage	0	V _{CC} -2	V
I _O Collector voltage		40	V
I _{IL} Output current (each output), sink or source		200	mA
Current into feedback terminal		0.3	mA
C _T Timing capacitor	0.00047	10	μF
R _T Timing resistor	1.8	500	kΩ
f _{osc} Oscillator frequency	1	300	kHz
T _A Operating free-air temperature	0	70	°C

electrical characteristics over recommended operating free-air temperature range, V_{CC} = 15 V (unless otherwise noted)

reference section (see Note 4)

PARAMETER	TEST CONDITIONS†	MIN	TYP‡	MAX	UNIT	
Output voltage (REF)	I _O = 1 mA	T _A = 25°C	4.95	5	5.05	V
		T _A = full range	4.9		5.1	
Input regulation	V _{CC} = 7 V to 40 V		2	25	mV	
Output regulation	I _O = 1 mA to 10 mA	T _A = 25°C		1	15	mV
		T _A = full range			50	
Output voltage change with temperature	ΔT _A = MIN to MAX		2	10	mV/V	
Short-circuit output current§	REF = 0 V	-10	-48		mA	

† Full range is 0°C to 70°C.

‡ All typical values, except for parameter changes with temperature, are at T_A = 25°C.

§ Duration of the short circuit should not exceed one second.

NOTE 4: Pulse-testing techniques that maintain the junction temperature as close to the ambient temperature as possible must be used.

oscillator section, C_T = 0.001 μF, R_T = 12 kΩ (see Figure 1) (see Note 4)

PARAMETER	TEST CONDITIONS†	MIN	TYP‡	MAX	UNIT
Frequency			100		kHz
Standard deviation of frequency¶	All values of V _{CC} , C _T , R _T , T _A constant		100		Hz/kHz
Frequency change with voltage	V _{CC} = 7 V to 40 V, T _A = 25°C		1	10	Hz/kHz
Frequency change with temperature#	ΔT _A = full range		70	120	Hz/kHz
	ΔT _A = full range, C _T = 0.01 μF		50	80	

† Full range is 0°C to 70°C.

‡ All typical values, except for parameter changes with temperature, are at T_A = 25°C.

¶ Standard deviation is a measure of the statistical distribution about the mean, as derived from the formula:

$$\sigma = \sqrt{\frac{\sum_{n=1}^N (x_n - \bar{x})^2}{N - 1}}$$

Effects of temperature on external R_T and C_T are not taken into account.

NOTE 4: Pulse-testing techniques that maintain the junction temperature as close to the ambient temperature as possible must be used.

TL598

PULSE-WIDTH-MODULATION CONTROL CIRCUITS

SLVS053D – FEBRUARY 1988 – REVISED NOVEMBER 2003

electrical characteristics over recommended operating free-air temperature range, $V_{CC} = 15\text{ V}$ (unless otherwise noted) (continued)

error amplifier section (see Note 4)

PARAMETER	TEST CONDITIONS	MIN	TYP†	MAX	UNIT
Input offset voltage	FEEDBACK = 2.5 V		2	10	mV
Input offset current	FEEDBACK = 2.5 V		25	250	nA
Input bias current	FEEDBACK = 2.5 V		0.2	1	μA
Common-mode input voltage range	$V_{CC} = 7\text{ V to } 40\text{ V}$		0 to $V_{CC}-2$		V
Open-loop voltage amplification	ΔV_O (FEEDBACK) = 3 V, V_O (FEEDBACK) = 0.5 V to 3.5 V	70	95		dB
Unity-gain bandwidth			800		kHz
Common-mode rejection ratio	$V_{CC} = 40\text{ V}$, $\Delta V_{IC} = 6.5\text{ V}$, $T_A = 25^\circ\text{C}$	65	80		dB
Output sink current (FEEDBACK)	FEEDBACK = 0.5 V	0.3	0.7		mA
Output source current (FEEDBACK)	FEEDBACK = 3.5 V	-2			mA
Phase margin at unity gain	FEEDBACK = 0.5 V to 3.5 V, $R_L = 2\text{ k}\Omega$		65°		
Supply-voltage rejection ratio	FEEDBACK = 2.5 V, $\Delta V_{CC} = 33\text{ V}$, $R_L = 2\text{ k}\Omega$		100		dB

† All typical values, except for parameter changes with temperature, are at $T_A = 25^\circ\text{C}$.

NOTE 4. Pulse-testing techniques that maintain the junction temperature as close to the ambient temperature as possible must be used.

electrical characteristics over recommended operating free-air temperature range, $V_{CC} = 15\text{ V}$ (unless otherwise noted)

undervoltage lockout section (see Note 4)

PARAMETER	TEST CONDITIONS‡	MIN	MAX	UNIT
Threshold voltage	$T_A = 25^\circ\text{C}$	4	6	V
	$\Delta T_A = \text{full range}$	3.5	6.9	
Hysteresis§	$T_A = 25^\circ\text{C}$	100		mV
	$T_A = \text{full range}$	50		

‡ Full range is 0°C to 70°C .

§ Hysteresis is the difference between the positive-going input threshold voltage and the negative-going input threshold voltage.

NOTE 4. Pulse-testing techniques must be used that maintain the junction temperature as close to the ambient temperature as possible.

output section (see Note 4)

PARAMETER	TEST CONDITIONS	MIN	MAX	UNIT
High-level output voltage	$V_{CC} = 15\text{ V}$, $V_C = 15\text{ V}$, $I_O = -200\text{ mA}$	12		V
	$I_O = -20\text{ mA}$	13		
Low-level output voltage	$V_{CC} = 15\text{ V}$, $V_C = 15\text{ V}$, $I_O = 200\text{ mA}$		2	V
	$I_O = 20\text{ mA}$		0.4	
Output-control input current	$V_I = V_{\text{ref}}$		3.5	mA
	$V_I = 0.4\text{ V}$		100	μA

NOTE 4. Pulse-testing techniques must be used that maintain the junction temperature as close to the ambient temperature as possible.



electrical characteristics over recommended operating free-air temperature range, $V_{CC} = 15\text{ V}$ (unless otherwise noted) (continued)

dead-time control section (see Figure 1) (see Note 4)

PARAMETER	TEST CONDITIONS	MIN	TYP†	MAX	UNIT
Input bias current (DTC)	$V_I = 0$ to 5.25 V		-2	-10	μA
Maximum duty cycle, each output	DTC = 0 V	0.45			
Input threshold voltage (DTC)	Zero duty cycle		3	3.3	V
	Maximum duty cycle	0			

† All typical values, except for parameter changes with temperature, are at $T_A = 25^\circ\text{C}$.

NOTE 4. Pulse-testing techniques must be used that maintain the junction temperature as close to the ambient temperature as possible.

pwm comparator section (see Note 4)

PARAMETER	TEST CONDITIONS	MIN	TYP†	MAX	UNIT
Input threshold voltage (FEEDBACK)	DTC = 0 V		3.75	4.5	V
Input sink current (FEEDBACK)	$V_{(\text{FEEDBACK})} = 0.5\text{ V}$	0.3	0.7		mA

† All typical values, except for parameter changes with temperature, are at $T_A = 25^\circ\text{C}$.

NOTE Pulse-testing techniques must be used that maintain the junction temperature as close to the ambient temperature as possible.

total device (see Figure 1) (see Note 4)

PARAMETER	TEST CONDITIONS	MIN	TYP†	MAX	UNIT
Standby supply current	RT = V_{ref} , All other inputs and outputs open	$V_{CC} = 15\text{ V}$	15	21	mA
		$V_{CC} = 40\text{ V}$	20	26	
Average supply current	DTC = 2 V		15		mA

† All typical values, except for parameter changes with temperature, are at $T_A = 25^\circ\text{C}$.

NOTE 4. Pulse-testing techniques must be used that maintain the junction temperature as close to the ambient temperature as possible.

switching characteristics, $T_A = 25^\circ\text{C}$ (see Note 4)

PARAMETER	TEST CONDITIONS	MIN	TYP	MAX	UNIT
Output-voltage rise time	CL = 1500 pF , See Figure 2		60	150	ns
Output-voltage fall time					

NOTE 4. Pulse-testing techniques must be used that maintain the junction temperature as close to the ambient temperature as possible.

TL598 PULSE-WIDTH-MODULATION CONTROL CIRCUITS

SLVS053D – FEBRUARY 1988 – REVISED NOVEMBER 2003

PARAMETER MEASUREMENT INFORMATION

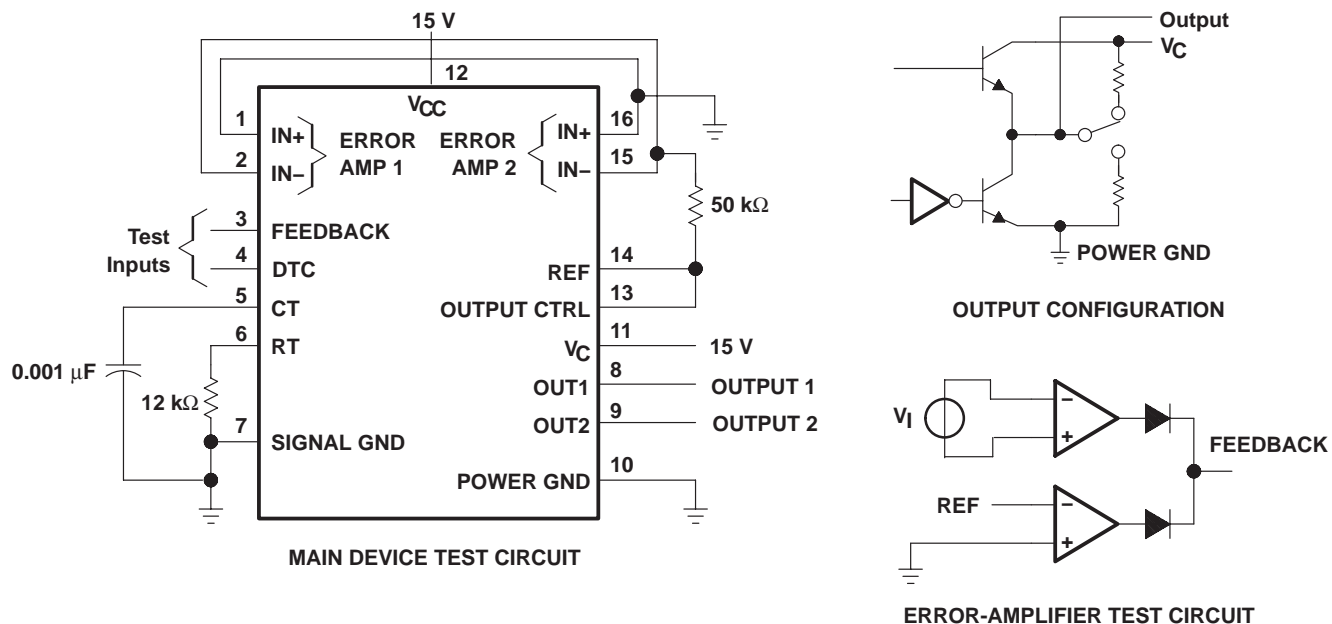

Figure 1. Test Circuits

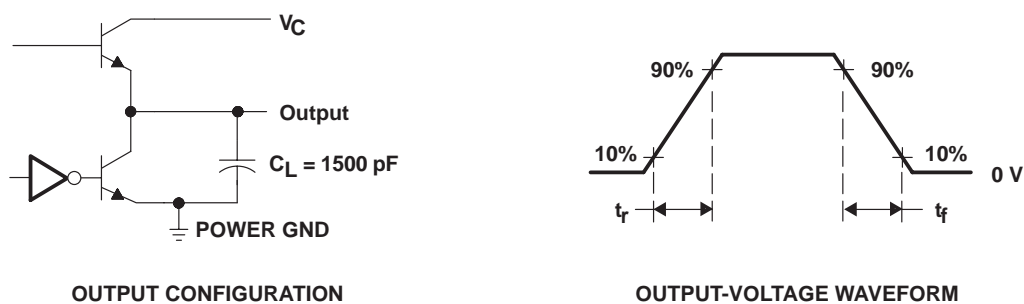
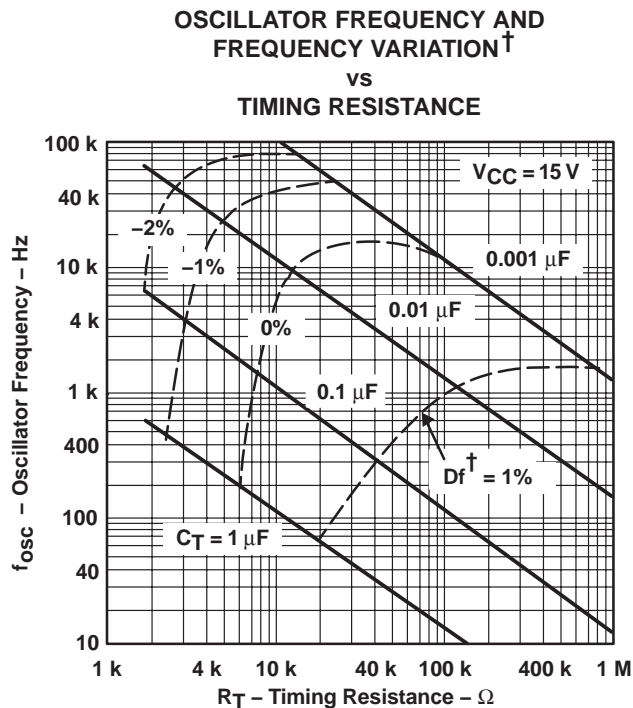

Figure 2. Switching Output Configuration and Voltage Waveform

TYPICAL CHARACTERISTICS



[†] Frequency variation (Δf) is the change in predicted oscillator frequency that occurs over the full temperature range.

Figure 3

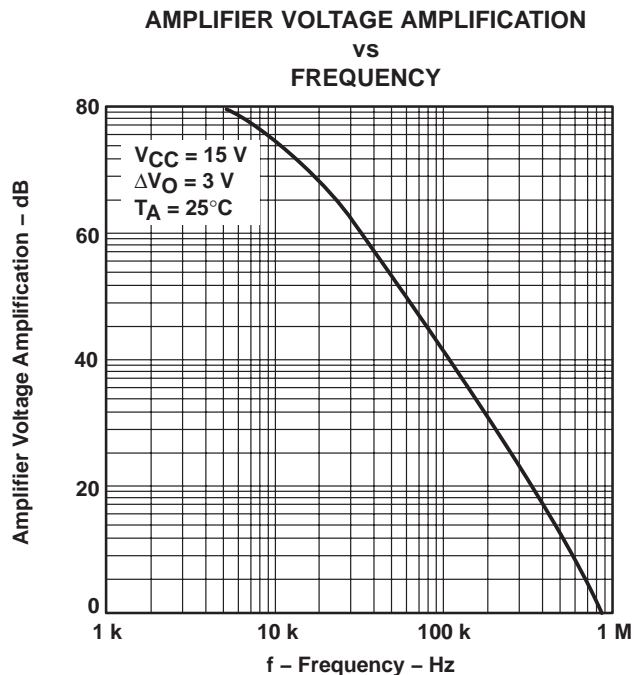

Figure 4

PACKAGING INFORMATION

Orderable Device	Status (1)	Package Type	Package Drawing	Pins	Package Qty	Eco Plan (2)	Lead/Ball Finish (6)	MSL Peak Temp (3)	Op Temp (°C)	Device Marking (4/5)	Samples
5962-9166801QEA	OBSOLETE	CDIP	J	16		TBD	Call TI	Call TI	-55 to 125		
TL598CD	ACTIVE	SOIC	D	16	40	Green (RoHS & no Sb/Br)	CU NIPDAU	Level-1-260C-UNLIM	0 to 70	TL598C	Samples
TL598CDG4	ACTIVE	SOIC	D	16	40	Green (RoHS & no Sb/Br)	CU NIPDAU	Level-1-260C-UNLIM	0 to 70	TL598C	Samples
TL598CDR	ACTIVE	SOIC	D	16	2500	Green (RoHS & no Sb/Br)	CU NIPDAU	Level-1-260C-UNLIM	0 to 70	TL598C	Samples
TL598CDRG4	ACTIVE	SOIC	D	16	2500	Green (RoHS & no Sb/Br)	CU NIPDAU	Level-1-260C-UNLIM	0 to 70	TL598C	Samples
TL598CN	ACTIVE	PDIP	N	16	25	Pb-Free (RoHS)	CU NIPDAU	N / A for Pkg Type	0 to 70	TL598CN	Samples
TL598CNE4	ACTIVE	PDIP	N	16	25	Pb-Free (RoHS)	CU NIPDAU	N / A for Pkg Type	0 to 70	TL598CN	Samples
TL598MFKB	OBSOLETE	LCCC	FK	20		TBD	Call TI	Call TI	-55 to 125		
TL598MJB	OBSOLETE	CDIP	J	16		TBD	Call TI	Call TI	-55 to 125		
TL598QD	OBSOLETE	SOIC	D	16		TBD	Call TI	Call TI	-40 to 125		
TL598QDR	OBSOLETE	SOIC	D	16		TBD	Call TI	Call TI	-40 to 125		
TL598QN	OBSOLETE	PDIP	N	16		TBD	Call TI	Call TI	-40 to 125		

(1) The marketing status values are defined as follows:

ACTIVE: Product device recommended for new designs.

LIFEBUY: TI has announced that the device will be discontinued, and a lifetime-buy period is in effect.

NRND: Not recommended for new designs. Device is in production to support existing customers, but TI does not recommend using this part in a new design.

PREVIEW: Device has been announced but is not in production. Samples may or may not be available.

OBSOLETE: TI has discontinued the production of the device.

(2) Eco Plan - The planned eco-friendly classification: Pb-Free (RoHS), Pb-Free (RoHS Exempt), or Green (RoHS & no Sb/Br) - please check <http://www.ti.com/productcontent> for the latest availability information and additional product content details.

TBD: The Pb-Free/Green conversion plan has not been defined.

Pb-Free (RoHS): TI's terms "Lead-Free" or "Pb-Free" mean semiconductor products that are compatible with the current RoHS requirements for all 6 substances, including the requirement that lead not exceed 0.1% by weight in homogeneous materials. Where designed to be soldered at high temperatures, TI Pb-Free products are suitable for use in specified lead-free processes.

Pb-Free (RoHS Exempt): This component has a RoHS exemption for either 1) lead-based flip-chip solder bumps used between the die and package, or 2) lead-based die adhesive used between the die and leadframe. The component is otherwise considered Pb-Free (RoHS compatible) as defined above.

Green (RoHS & no Sb/Br): TI defines "Green" to mean Pb-Free (RoHS compatible), and free of Bromine (Br) and Antimony (Sb) based flame retardants (Br or Sb do not exceed 0.1% by weight in homogeneous material)

- (3) MSL, Peak Temp. - The Moisture Sensitivity Level rating according to the JEDEC industry standard classifications, and peak solder temperature.
- (4) There may be additional marking, which relates to the logo, the lot trace code information, or the environmental category on the device.
- (5) Multiple Device Markings will be inside parentheses. Only one Device Marking contained in parentheses and separated by a "~" will appear on a device. If a line is indented then it is a continuation of the previous line and the two combined represent the entire Device Marking for that device.
- (6) Lead/Ball Finish - Orderable Devices may have multiple material finish options. Finish options are separated by a vertical ruled line. Lead/Ball Finish values may wrap to two lines if the finish value exceeds the maximum column width.

Important Information and Disclaimer:The information provided on this page represents TI's knowledge and belief as of the date that it is provided. TI bases its knowledge and belief on information provided by third parties, and makes no representation or warranty as to the accuracy of such information. Efforts are underway to better integrate information from third parties. TI has taken and continues to take reasonable steps to provide representative and accurate information but may not have conducted destructive testing or chemical analysis on incoming materials and chemicals. TI and TI suppliers consider certain information to be proprietary, and thus CAS numbers and other limited information may not be available for release.

In no event shall TI's liability arising out of such information exceed the total purchase price of the TI part(s) at issue in this document sold by TI to Customer on an annual basis.

TAPE AND REEL INFORMATION



QUADRANT ASSIGNMENTS FOR PIN 1 ORIENTATION IN TAPE



*All dimensions are nominal

Device	Package Type	Package Drawing	Pins	SPQ	Reel Diameter (mm)	Reel Width W1 (mm)	A0 (mm)	B0 (mm)	K0 (mm)	P1 (mm)	W (mm)	Pin1 Quadrant
TL598CDR	SOIC	D	16	2500	330.0	16.4	6.5	10.3	2.1	8.0	16.0	Q1

TAPE AND REEL BOX DIMENSIONS



*All dimensions are nominal

Device	Package Type	Package Drawing	Pins	SPQ	Length (mm)	Width (mm)	Height (mm)
TL598CDR	SOIC	D	16	2500	333.2	345.9	28.6

J (R-GDIP-T**)

14 LEADS SHOWN

CERAMIC DUAL IN-LINE PACKAGE



DIM \ PINS **	14	16	18	20
A	0.300 (7,62) BSC	0.300 (7,62) BSC	0.300 (7,62) BSC	0.300 (7,62) BSC
B MAX	0.785 (19,94)	.840 (21,34)	0.960 (24,38)	1.060 (26,92)
B MIN	—	—	—	—
C MAX	0.300 (7,62)	0.300 (7,62)	0.310 (7,87)	0.300 (7,62)
C MIN	0.245 (6,22)	0.245 (6,22)	0.220 (5,59)	0.245 (6,22)



4040083/F 03/03

- NOTES:
- All linear dimensions are in inches (millimeters).
 - This drawing is subject to change without notice.
 - This package is hermetically sealed with a ceramic lid using glass frit.
 - Index point is provided on cap for terminal identification only on press ceramic glass frit seal only.
 - Falls within MIL STD 1835 GDIP1-T14, GDIP1-T16, GDIP1-T18 and GDIP1-T20.

FK (S-CQCC-N**)

LEADLESS CERAMIC CHIP CARRIER

28 TERMINAL SHOWN



NO. OF TERMINALS **	A		B	
	MIN	MAX	MIN	MAX
20	0.342 (8,69)	0.358 (9,09)	0.307 (7,80)	0.358 (9,09)
28	0.442 (11,23)	0.458 (11,63)	0.406 (10,31)	0.458 (11,63)
44	0.640 (16,26)	0.660 (16,76)	0.495 (12,58)	0.560 (14,22)
52	0.740 (18,78)	0.761 (19,32)	0.495 (12,58)	0.560 (14,22)
68	0.938 (23,83)	0.962 (24,43)	0.850 (21,6)	0.858 (21,8)
84	1.141 (28,99)	1.165 (29,59)	1.047 (26,6)	1.063 (27,0)



4040140/D 01/11

- NOTES:
- All linear dimensions are in inches (millimeters).
 - This drawing is subject to change without notice.
 - This package can be hermetically sealed with a metal lid.
 - Falls within JEDEC MS-004

N (R-PDIP-T**)

PLASTIC DUAL-IN-LINE PACKAGE

16 PINS SHOWN



- NOTES:
- A. All linear dimensions are in inches (millimeters).
 - B. This drawing is subject to change without notice.
 - Falls within JEDEC MS-001, except 18 and 20 pin minimum body length (Dim A).
 - The 20 pin end lead shoulder width is a vendor option, either half or full width.

D (R-PDSO-G16)

PLASTIC SMALL OUTLINE



- NOTES:
- A. All linear dimensions are in inches (millimeters).
 - B. This drawing is subject to change without notice.
 - C. Body length does not include mold flash, protrusions, or gate burrs. Mold flash, protrusions, or gate burrs shall not exceed 0.006 (0,15) each side.
 - D. Body width does not include interlead flash. Interlead flash shall not exceed 0.017 (0,43) each side.
 - E. Reference JEDEC MS-012 variation AC.

D (R-PDSO-G16)

PLASTIC SMALL OUTLINE



- NOTES:
- All linear dimensions are in millimeters.
 - This drawing is subject to change without notice.
 - Publication IPC-7351 is recommended for alternate designs.
 - Laser cutting apertures with trapezoidal walls and also rounding corners will offer better paste release. Customers should contact their board assembly site for stencil design recommendations. Refer to IPC-7525 for other stencil recommendations.
 - Customers should contact their board fabrication site for solder mask tolerances between and around signal pads.

IMPORTANT NOTICE

Texas Instruments Incorporated and its subsidiaries (TI) reserve the right to make corrections, enhancements, improvements and other changes to its semiconductor products and services per JESD46, latest issue, and to discontinue any product or service per JESD48, latest issue. Buyers should obtain the latest relevant information before placing orders and should verify that such information is current and complete. All semiconductor products (also referred to herein as "components") are sold subject to TI's terms and conditions of sale supplied at the time of order acknowledgment.

TI warrants performance of its components to the specifications applicable at the time of sale, in accordance with the warranty in TI's terms and conditions of sale of semiconductor products. Testing and other quality control techniques are used to the extent TI deems necessary to support this warranty. Except where mandated by applicable law, testing of all parameters of each component is not necessarily performed.

TI assumes no liability for applications assistance or the design of Buyers' products. Buyers are responsible for their products and applications using TI components. To minimize the risks associated with Buyers' products and applications, Buyers should provide adequate design and operating safeguards.

TI does not warrant or represent that any license, either express or implied, is granted under any patent right, copyright, mask work right, or other intellectual property right relating to any combination, machine, or process in which TI components or services are used. Information published by TI regarding third-party products or services does not constitute a license to use such products or services or a warranty or endorsement thereof. Use of such information may require a license from a third party under the patents or other intellectual property of the third party, or a license from TI under the patents or other intellectual property of TI.

Reproduction of significant portions of TI information in TI data books or data sheets is permissible only if reproduction is without alteration and is accompanied by all associated warranties, conditions, limitations, and notices. TI is not responsible or liable for such altered documentation. Information of third parties may be subject to additional restrictions.

Resale of TI components or services with statements different from or beyond the parameters stated by TI for that component or service voids all express and any implied warranties for the associated TI component or service and is an unfair and deceptive business practice. TI is not responsible or liable for any such statements.

Buyer acknowledges and agrees that it is solely responsible for compliance with all legal, regulatory and safety-related requirements concerning its products, and any use of TI components in its applications, notwithstanding any applications-related information or support that may be provided by TI. Buyer represents and agrees that it has all the necessary expertise to create and implement safeguards which anticipate dangerous consequences of failures, monitor failures and their consequences, lessen the likelihood of failures that might cause harm and take appropriate remedial actions. Buyer will fully indemnify TI and its representatives against any damages arising out of the use of any TI components in safety-critical applications.

In some cases, TI components may be promoted specifically to facilitate safety-related applications. With such components, TI's goal is to help enable customers to design and create their own end-product solutions that meet applicable functional safety standards and requirements. Nonetheless, such components are subject to these terms.

No TI components are authorized for use in FDA Class III (or similar life-critical medical equipment) unless authorized officers of the parties have executed a special agreement specifically governing such use.

Only those TI components which TI has specifically designated as military grade or "enhanced plastic" are designed and intended for use in military/aerospace applications or environments. Buyer acknowledges and agrees that any military or aerospace use of TI components which have **not** been so designated is solely at the Buyer's risk, and that Buyer is solely responsible for compliance with all legal and regulatory requirements in connection with such use.

TI has specifically designated certain components as meeting ISO/TS16949 requirements, mainly for automotive use. In any case of use of non-designated products, TI will not be responsible for any failure to meet ISO/TS16949.

Products

Audio	www.ti.com/audio
Amplifiers	amplifier.ti.com
Data Converters	dataconverter.ti.com
DLP® Products	www.dlp.com
DSP	dsp.ti.com
Clocks and Timers	www.ti.com/clocks
Interface	interface.ti.com
Logic	logic.ti.com
Power Mgmt	power.ti.com
Microcontrollers	microcontroller.ti.com
RFID	www.ti-rfid.com
OMAP Applications Processors	www.ti.com/omap
Wireless Connectivity	www.ti.com/wirelessconnectivity

Applications

Automotive and Transportation	www.ti.com/automotive
Communications and Telecom	www.ti.com/communications
Computers and Peripherals	www.ti.com/computers
Consumer Electronics	www.ti.com/consumer-apps
Energy and Lighting	www.ti.com/energy
Industrial	www.ti.com/industrial
Medical	www.ti.com/medical
Security	www.ti.com/security
Space, Avionics and Defense	www.ti.com/space-avionics-defense
Video and Imaging	www.ti.com/video

TI E2E Community

e2e.ti.com