

## Ten-Output Low-Jitter Low-Power Clock Buffer and Level Translator

Check for Samples: [CDCLVC1310](#)

### FEATURES

- **High-Performance Crystal Buffer With Ultralow Noise Floor of  $-169$  dBc/Hz**
- **Additive Phase Noise/Jitter Performance Is  $25$  fs<sub>RMS</sub> (Typ.)**
- **Level Translation With 3.3-V or 2.5-V Core and 3.3-V, 2.5-V, 1.8-V, or 1.5-V Output Supply**
- **Device inputs consist of primary, secondary, and crystal inputs, and manually selectable (through pins) using the input MUX. The primary and secondary inputs can accept LVPECL, LVDS, HCSL, SSTL or LVCMOS signals and crystal input.**
  - **Crystal Frequencies Supported Are From 8 MHz to 50 MHz**
  - **Differential and Single-Ended Input Frequencies Supported Are up to 200 MHz**
- **10 Single-Ended LVCMOS Outputs. The outputs can operate at 1.5-V, 1.8-V, 2.5-V or 3.3-V Power-Supply Voltage.**
  - **LVCMOS Outputs Operate up to 200 MHz**
  - **Output Skew Is 30 ps (Typical)**
  - **Total Propagation Delay Is 2 ns (Typical)**
  - **Synchronous and Glitch-Free Output Enable Is Available**
- **Offered in QFN-32 5-mm × 5-mm Package With Industrial Temperature Range of  $-40^{\circ}\text{C}$  to  $85^{\circ}\text{C}$**
- **Can Overdrive Crystal Input With LVCMOS Signal up to 50 MHz**

### APPLICATIONS

- **Wireless and Wired Infrastructure**
- **Networking and Data Communications**
- **Medical Imaging**
- **Portable Test and Measurement**
- **High-End A/V**

### DESCRIPTION

The CDCLVC1310 is a highly versatile, low-jitter, low-power clock fanout buffer which can distribute to ten low-jitter LVCMOS clock outputs from one of three inputs, whose primary and secondary inputs can feature differential or single-ended signals and crystal input. Such a buffer is good for use in a variety of mobile and wired infrastructure, data communication, computing, low-power medical imaging, and portable test and measurement applications. When the input is an illegal level, the output is at a defined state. One can set the core to 2.5 V or 3.3 V, and output to 1.5 V, 1.8 V, 2.5 V or 3.3 V. Pin programming easily configures the CDCLVC1310. The overall additive jitter performance is 25 fs<sub>RMS</sub> (typical). The CDCLVC1310 comes in a small 32-pin 5-mm × 5-mm QFN package.



Please be aware that an important notice concerning availability, standard warranty, and use in critical applications of Texas Instruments semiconductor products and disclaimers thereto appears at the end of this data sheet.



These devices have limited built-in ESD protection. The leads should be shorted together or the device placed in conductive foam during storage or handling to prevent electrostatic damage to the MOS gates.

**BLOCK DIAGRAM**

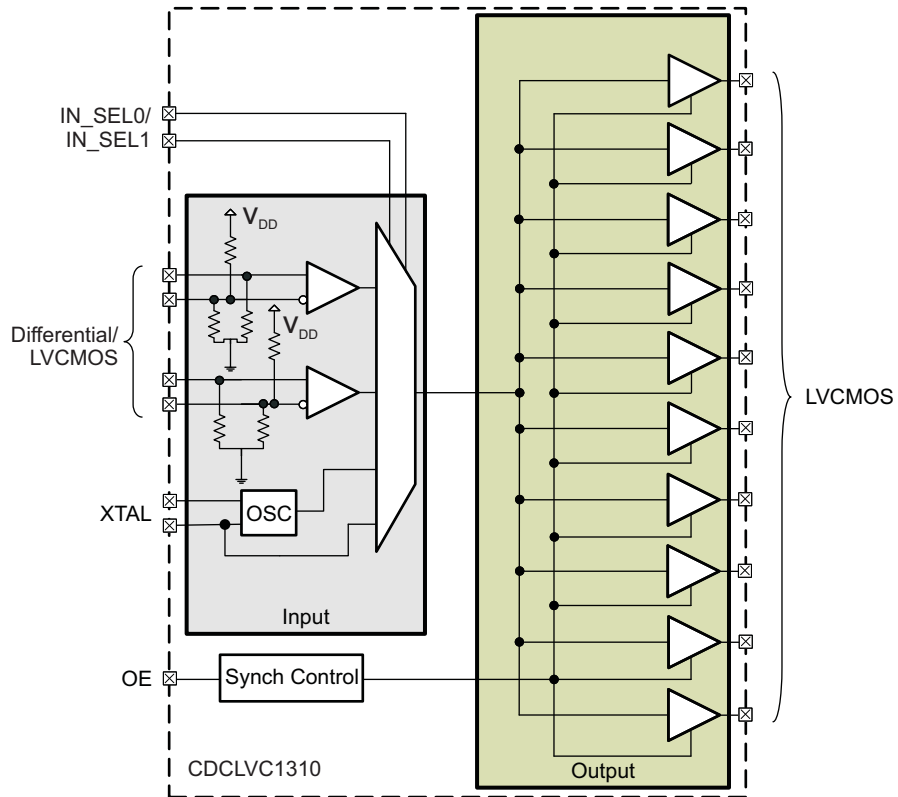

**Figure 1. High-Level Block Diagram of CDCLVC1310**

**PINOUT DIAGRAM**

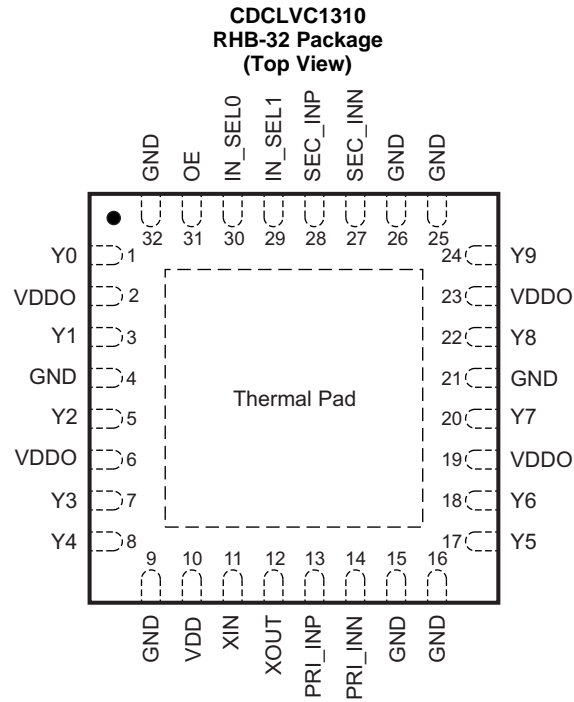

P0048-18

## PIN FUNCTIONS

PIN		I/O	TYPE	DESCRIPTION
NAME	NO(s)			
GND	4, 9, 15, 16, 21, 25, 26, 32	PWR	Analog	Power-supply ground
IN_SELO, IN_SEL1	30, 29	I	Digital	Input-clock selection (pulldown of 150 kΩ)
OE	31	I	Digital	LVC MOS output enable (pulldown of 150 kΩ)
PRI_INN	14	I	Analog	Inverting differential primary reference input, internally biased to Vdd / 2 (pullup or pulldown of 150 kΩ)
PRI_INP	13	I	Analog	Non-inverting differential or single-ended primary reference input (pulldown of 150 kΩ)
SEC_INN	27	I	Analog	Inverting differential secondary reference input, internally biased to Vdd / 2 (pullup or pulldown of 150 kΩ)
SEC_INP	28	I	Analog	Non-inverting differential or single-ended secondary reference input (pulldown of 150 kΩ)
VDD	10	PWR	Analog	Power-supply pins
VDDO	2, 6, 19, 23	PWR	Analog	I/O power-supply pins
XIN	11	I	Analog	Crystal-oscillator input or XTAL bypass mode
XOUT	12	I	Analog	Crystal-oscillator output
Y0	1	O	Analog	LVC MOS output 0
Y1	3	O	Analog	LVC MOS output 1
Y2	5	O	Analog	LVC MOS output 2
Y3	7	O	Analog	LVC MOS output 3
Y4	8	O	Analog	LVC MOS output 4
Y5	17	O	Analog	LVC MOS output 5
Y6	18	O	Analog	LVC MOS output 6
Y7	20	O	Analog	LVC MOS output 7
Y8	22	O	Analog	LVC MOS output 8
Y9	24	O	Analog	LVC MOS output 9

Table 1. Input Selection

IN_SEL1	IN_SELO	INPUT CHOSEN
0	0	PRI_IN
0	1	SEC_IN
1	0	XTAL or overdrive <sup>(1)</sup>
1	1	XTAL bypass <sup>(2)</sup>

- (1) This mode is for XTAL input or overdrive of XTAL oscillator with LVC MOS input. For characteristics; see [LVC MOS OUTPUT CHARACTERISTICS](#).
- (2) This mode is only XTAL bypass. For characteristics, see [LVC MOS OUTPUT CHARACTERISTICS](#).

Table 2. INPUT/OUTPUT OPERATION<sup>(1)</sup>

INPUT STATE	OUTPUT STATE
PRI_INx, SEC_INx open	Logic LOW
PRI_INP, SEC_INP = HIGH, PRI_INN, SEC_INN = LOW	Logic HIGH
PRI_INP, SEC_INP = LOW, PRI_INN, SEC_INN = HIGH	Logic LOW

- (1) Device must have switching edge to obtain output states.

**Table 3. OE Function**

OE	Yx
0	High-impedance
1	Enabled

**ABSOLUTE MAXIMUM RATINGS<sup>(1)</sup>**

over operating free-air temperature range (unless otherwise noted)

		VALUE	UNIT
VDD, VDDO	Supply-voltage range	–0.5 to 4.6	V
V <sub>IN</sub>	Input-voltage range	–0.5 to VDD + 0.5	V
V <sub>OUT</sub>	Output-voltage range	–0.5 to VDDO + 0.5	V
I <sub>IN</sub>	Input current	±20	V
I <sub>OUT</sub>	Output current	±50	V
T <sub>stg</sub>	Storage-temperature range	–65 to 150	°C
T <sub>J</sub>	Junction temperature	125	°C

(1) Stresses beyond those listed under *Absolute Maximum Ratings* may cause permanent damage to the device. These are stress ratings only, and functional operation of the device at these or any other conditions beyond those indicated under *Recommended Operating Conditions* is not implied. Exposure to absolute-maximum-rated conditions for extended periods may affect device reliability.

**RECOMMENDED OPERATING CONDITIONS**

over operating free-air temperature range (unless otherwise noted)

		MIN	NOM	MAX	UNIT
VDDO	Output supply voltage	3.135	3.3	3.465	V
		2.375	2.5	2.625	
		1.6	1.8	2	
		1.35	1.5	1.65	
VDD	Core supply voltage	3.135	3.3	3.465	V
		2.375	2.5	2.625	
I <sub>OH</sub>	High-level output current, LVCMOS			–24	mA
I <sub>OL</sub>	Low-level output current, LVCMOS			24	mA
T <sub>A</sub>	Ambient temperature	–40		85	°C

## THERMAL INFORMATION

THERMAL METRIC <sup>(1)</sup>		CDCLVC1310	
		RHB	
		32 PINS	
			UNIT
$\theta_{JA}$	Junction-to-ambient thermal resistance <sup>(2)</sup>	41.7	°C/W
$\theta_{JcTop}$	Junction-to-case (top) thermal resistance <sup>(3)</sup>	34.1	°C/W
$\theta_{JB}$	Junction-to-board thermal resistance <sup>(4)</sup>	14.4	°C/W
$\psi_{JT}$ <sup>(5)</sup>	Junction-to-top characterization parameter <sup>(5)</sup>	0.9	°C/W
$\psi_{JB}$ <sup>(6)</sup>	Junction-to-board characterization parameter <sup>(6)</sup>	14.4	°C/W
$\theta_{JcBot}$	Junction-to-case (bottom) thermal resistance <sup>(7)</sup>	6.2	°C/W

- (1) For more information about traditional and new thermal metrics, see the *IC Package Thermal Metrics* application report, [SPRA953](#).
- (2) The junction-to-ambient thermal resistance under natural convection is obtained in a simulation on a JEDEC-standard, high-K board, as specified in JESD51-7, in an environment described in JESD51-2a.
- (3) The junction-to-case (top) thermal resistance is obtained by simulating a cold plate test on the package top. No specific JEDEC-standard test exists, but a close description can be found in the ANSI SEMI standard G30-88.
- (4) The junction-to-board thermal resistance is obtained by simulating in an environment with a ring cold plate fixture to control the PCB temperature, as described in JESD51-8.
- (5) The junction-to-top characterization parameter,  $\psi_{JT}$ , estimates the junction temperature of a device in a real system and is extracted from the simulation data for obtaining  $\theta_{JA}$ , using a procedure described in JESD51-2a (sections 6 and 7).
- (6) The junction-to-board characterization parameter,  $\psi_{JB}$ , estimates the junction temperature of a device in a real system and is extracted from the simulation data for obtaining  $\theta_{JA}$ , using a procedure described in JESD51-2a (sections 6 and 7).
- (7) The junction-to-case (bottom) thermal resistance is obtained by simulating a cold plate test on the exposed (power) pad. No specific JEDEC standard test exists, but a close description can be found in the ANSI SEMI standard G30-88.

## INPUT CHARACTERISTICS

over recommended ranges of supply voltage ( $V_{DD0} \leq V_{DD}$ ), load and ambient temperature (unless otherwise noted)

PARAMETER		TEST CONDITIONS	MIN	TYP	MAX	UNIT
<b>DC Characteristic (OE, IN_SEL0, IN_SEL1, PRI_IN, SEC_IN)</b>						
$I_{IH}$	Input high current	$V_{DD} = 3.465 \text{ V}$ , $V_{IH} = 3.465 \text{ V}$			40	$\mu\text{A}$
$I_{IL}$	Input low current	$V_{DD} = 3.465 \text{ V}$ , $V_{IL} = 0 \text{ V}$			-40	$\mu\text{A}$
$\Delta V/\Delta T$	Input edge rate	20%–80%		2		V/ns
$R_{Pullup/down}$	Pullup or pulldown resistance			150		k $\Omega$
$C_{IN}$	Input capacitance			2		pF
<b>Single-Ended DC Characteristic (PRI_INP, SEC_INP)<sup>(1)</sup></b>						
$V_{IH}$	Input high voltage	$V_{DD} = 3.3 \text{ V} \pm 5\%$	2		$V_{DD} + 0.3$	V
		$V_{DD} = 2.5 \text{ V} \pm 5\%$	1.6		$V_{DD} + 0.3$	
$V_{IL}$	Input low voltage	$V_{DD} = 3.3 \text{ V} \pm 5\%$	-0.3		1.3	V
		$V_{DD} = 2.5 \text{ V} \pm 5\%$	-0.3		0.9	
<b>Single-Ended DC Characteristic (OE, IN_SEL0, IN_SEL1)</b>						
$V_{IH}$	Input high voltage		$0.7 \times V_{DD}$			V
$V_{IL}$	Input low voltage				$0.3 \times V_{DD}$	V
<b>Differential DC Characteristic (PRI_IN, SEC_IN)</b>						
$V_{I,DIFF}$	Differential input voltage swing <sup>(2)</sup>		0.15		1.3	V
$V_{ICM}$	Input common-mode voltage <sup>(3)</sup>		0.5		$V_{DD} - 0.85$	V
<b>AC Characteristic (PRI_IN, SEC_IN)</b>						
$f_{IN}$	Input frequency		DC		200	MHz
$idc$	Input duty cycle		40%		60%	

- (1) PRI/SEC\_INN biased to  $V_{DD} / 2$
- (2)  $V_{IL}$  should not be less than  $-0.3 \text{ V}$
- (3) Input common-mode voltage is defined as  $V_{IH}$  (see [Figure 19](#)).

## CRYSTAL CHARACTERISTICS

over recommended ranges of supply voltage, load and ambient temperature (unless otherwise noted)

PARAMETER	TEST CONDITIONS	MIN	TYP	MAX	UNIT
Equivalent series resistance (ESR)			50		$\Omega$
Maximum shunt capacitance			7		pF
Drive level			100		$\mu$ W

## CRYSTAL OSCILLATOR CHARACTERISTICS

over recommended ranges of supply voltage, load and ambient temperature (unless otherwise noted)

PARAMETER	TEST CONDITIONS	MIN	TYP	MAX	UNIT
Mode of oscillation		Fundamental			
Frequency		8		50	MHz
Frequency in overdrive mode <sup>(1)</sup>				50	MHz
Frequency in bypass mode <sup>(2)</sup>				50	MHz
On-chip load capacitance			12		pF

(1) Input signal swing (max) = 2 V; input signal  $t_r$  (max) = 10 ns;  $t_f$ (max) = 10 ns; functional, but device may not meet ac parameters.

(2) Input signal swing (max) =  $V_{DD}$ ; input signal  $t_r$  (max) = 10 ns;  $t_f$ (max) = 10 ns; functional, but device may not meet ac parameters.

## LVC MOS OUTPUT CHARACTERISTICS

over recommended ranges of supply voltage ( $V_{DDO} \leq V_{DD}$ ), load (50  $\Omega$  to  $V_{DDO}/2$ ), and ambient temperature (unless otherwise noted)

PARAMETER	TEST CONDITIONS	MIN	TYP	MAX	UNIT
$f_{OUT}$				200	MHz
$V_{OH}$ Output high voltage	$V_{DDO} = 3.135 \text{ V to } 3.465 \text{ V}$	0.8 * $V_{DDO}$			V
	$V_{DDO} = 2.375 \text{ V to } 2.625 \text{ V}$	0.8 * $V_{DDO}$			
	$V_{DDO} = 1.6 \text{ V to } 2 \text{ V}$	0.7 * $V_{DDO}$			
	$V_{DDO} = 1.35 \text{ V to } 1.65 \text{ V}$	0.7 * $V_{DDO}$			
$V_{OL}$ Output low voltage	$V_{DDO} = 3.135 \text{ V to } 3.465 \text{ V}$			0.2 * $V_{DDO}$	V
	$V_{DDO} = 2.375 \text{ V to } 2.625 \text{ V}$			0.2 * $V_{DDO}$	
	$V_{DDO} = 1.6 \text{ V to } 2 \text{ V}$			0.3 * $V_{DDO}$	
	$V_{DDO} = 1.35 \text{ V to } 1.65 \text{ V}$			0.3 * $V_{DDO}$	
$R_{OUT}$ Output impedance	$V_{DDO} = 3.3 \text{ V}$		15		$\Omega$
	$V_{DDO} = 2.5 \text{ V}$		20		
	$V_{DDO} = 1.8 \text{ V}$		25		
	$V_{DDO} = 1.5 \text{ V}$		30		
$t_{SLEW-RATE}$ Output slew rate, rising and falling	$V_{DDO}=3.3\text{V} \pm 5\%$ , 20% to 80%	5.6	7.3	9.0	V/ns
	$V_{DDO}=2.5\text{V} \pm 5\%$ , 20% to 80%	3.9	4.8	5.4	
	$V_{DDO}=1.8\text{V} \pm 200\text{mV}$ , 20% to 80%	1.6	2.1	2.5	
	$V_{DDO}=1.5\text{V} \pm 150\text{mV}$ , 20% to 80%	0.9	1.2	1.4	
$t_{SK}$ Output skew			30	50	ps
$t_{SK,PP}$ Part-to-part skew <sup>(1)</sup>				2	ns

(1) Calculation for part-to-part skew is the difference between the fastest and the slowest  $t_{pd}$  across multiple devices.

## LVC MOS OUTPUT CHARACTERISTICS (continued)

over recommended ranges of supply voltage ( $V_{DDO} \leq V_{DD}$ ), load ( $50 \Omega$  to  $V_{DDO}/2$ ), and ambient temperature (unless otherwise noted)

PARAMETER		TEST CONDITIONS	MIN	TYP	MAX	UNIT
$t_{\text{DELAY}}$	Output frequency	VDD = 3.3 V $\pm 5\%$ , VDDO = 1.35 V to VDD	1.5	1.95	4.0	ns
		VDD = 2.5 V $\pm 5\%$ , VDDO = 1.35 V to VDD	1.8	2.4	4.4	
$t_{\text{RJIT}}$	System-level additive jitter <sup>(2)</sup>	Single-ended input, VDD = 3.3 V, VDDO = 3.3 V		25		$f_s$ , RMS
		Single-ended input, VDD = 2.5 V or 3.3 V, VDDO = 1.5 V, 1.8 V, or 2.5 V, $f_{\text{IN/OUT}} = 125$ MHz		30		
		Differential input, VDD = 3.3 V, VDDO = 3.3 V		30		
		Differential input, VDD = 2.5 V or 3.3 V, VDDO = 1.5 V, 1.8 V, or 2.5 V, $f_{\text{IN/OUT}} = 125$ MHz		30		
NF	Noise floor	10-kHz offset <sup>(3)</sup>		-145		dBc/Hz
		100-kHz offset <sup>(3)</sup>		-156		
		1-MHz offset <sup>(3)</sup>		-163		
		10-MHz offset <sup>(3)</sup>		-164		
		20-MHz offset <sup>(3)</sup>		-164		
		10-kHz offset <sup>(4)</sup>		-145		
		100-kHz offset <sup>(4)</sup>		-155		
		1-MHz offset <sup>(4)</sup>		-160		
		10-MHz offset <sup>(4)</sup>		-161		
20-MHz offset <sup>(4)</sup>		-162				
odc	Output duty cycle	$f_{\text{IN/OUT}} = 125$ MHz, $\text{idc} = 50\%$ <sup>(5)</sup>	45%		55%	
$t_{\text{EN}}$	Output enable or disable time				2	Cycle
$\text{MUX}_{\text{ISOLATION}}$	MUX isolation <sup>(6)</sup>	125 MHz	55			dB

(2) Integration range: 12 kHz–20 MHz; input source see the [System-Level Additive-Jitter Measurement](#) section

(3) Single-ended input,  $f_{\text{IN/OUT}} = 125$  MHz, VDD = VDDO = 3.3 V

(4) Differential input,  $f_{\text{IN/OUT}} = 125$  MHz, VDD = VDDO = 3.3 V

(5) Stable  $V_{\text{IH}}$ ,  $V_{\text{IL}}$ , and  $V_{\text{CM}}$

(6) See [Figure 18](#).



## PHASE NOISE WITH XTAL<sup>(1)</sup> SELECTED

VDD = VDDO = 2.5 V or 3.3 V,  $f_{XTAL} = 25$  MHz,  $T_A = 25^\circ\text{C}$  (unless otherwise noted)

PARAMETER		TEST CONDITIONS	MIN	TYP	MAX	UNIT
Jrms	RMS phase jitter	IB = 12 kHz to 5 MHz, VDD = VDDO = 3.3 V		80		fs rms
		IB = 12 kHz to 5 MHz, VDD = VDDO = 2.5 V		115		
PN	Phase noise (see <a href="#">Figure 15</a> )	$f_{offset} = 100$ Hz, VDD = VDDO = 3.3 V		-92		dBc/Hz
		$f_{offset} = 1$ kHz, VDD = VDDO = 3.3 V		-137		
		$f_{offset} = 10$ kHz, VDD = VDDO = 3.3 V		-163		
		$f_{offset} = 100$ kHz, VDD = VDDO = 3.3 V		-168		
		$f_{offset} = 1$ MHz, VDD = VDDO = 3.3 V		-168		
		$f_{offset} = 5$ MHz, VDD = VDDO = 3.3 V		-169		
		$f_{offset} = 100$ Hz, VDD = VDDO = 2.5 V		-91		
		$f_{offset} = 1$ kHz, VDD = VDDO = 2.5 V		-136		
		$f_{offset} = 10$ kHz, VDD = VDDO = 2.5 V		-159		
		$f_{offset} = 100$ kHz, VDD = VDDO = 2.5 V		-164		
		$f_{offset} = 1$ MHz, VDD = VDDO = 2.5 V		-165		
$f_{offset} = 5$ MHz, VDD = VDDO = 2.5 V		-165				

(1) Crystal specification:  $C_L = 18$  pF; ESR = 35  $\Omega$  (max);  $C_0 = 7$  pF; drive level = 100  $\mu\text{W}$  (max)

## DEVICE CURRENT CONSUMPTION

over recommended ranges of supply voltage, load and ambient temperature (unless otherwise noted)

PARAMETER		TEST CONDITIONS	MIN	TYP	MAX	UNIT
<b>OVERALL PARAMETERS FOR ALL VERSIONS</b>						
I <sub>DD</sub>	Static device current <sup>(1)</sup>	OE = 0 V or V <sub>DD</sub> ; Ref. input (PRI/SEC) = 0 V or V <sub>DD</sub> ; I <sub>O</sub> = 0 mA; V <sub>DD</sub> / V <sub>DDO</sub> = 3.3 V		14		mA
		OE = 0 V or V <sub>DD</sub> ; Ref. input (PRI/SEC) = 0 V or V <sub>DD</sub> ; I <sub>O</sub> = 0 mA; V <sub>DD</sub> / V <sub>DDO</sub> = 2.5 V		8		
I <sub>DD,XTAL</sub>	Device current with XTAL input <sup>(1)</sup>			20		mA
C <sub>PD</sub>	Power dissipation capacitance per output <sup>(2)</sup>	VDDO = 3.465 V; f = 100 MHz			8.8	pF
		VDDO = 2.625 V; f = 100 MHz			7.7	
		VDDO = 2 V; f = 100 MHz			7.3	
		VDDO = 1.65 V; f = 100 MHz			6.9	

(1) I<sub>DD</sub> and I<sub>DD,XTAL</sub> is the current through V<sub>DD</sub>; outputs enabled or in the high-impedance state; no load.

(2) This is the formula for the power dissipation calculation (see the [Power Considerations](#) section)

$$I_{DD,Total} = I_{DD} + I_{DD,Cload} + I_{DD,dyn} \text{ [mA]}$$

$$I_{DD,dyn} = C_{PD} \times V_{DDO} \times f \times n \text{ [mA]}$$

$$I_{DD,Cload} = C_{load} \times V_{DDO} \times f \times n \text{ [mA]}$$

$$n = \text{Number of switching output pins}$$

TEST CONFIGURATIONS

Figure 2 through Figure 8 illustrate how to set up the device for a variety of test configurations.

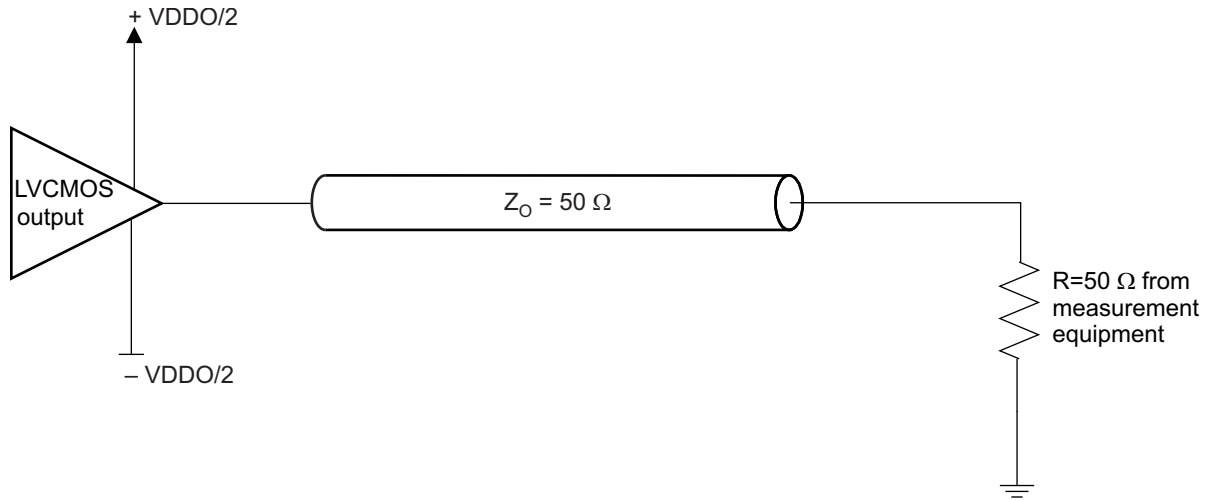

Figure 2. LVC MOS Output DC Configuration; Test Load Circuit

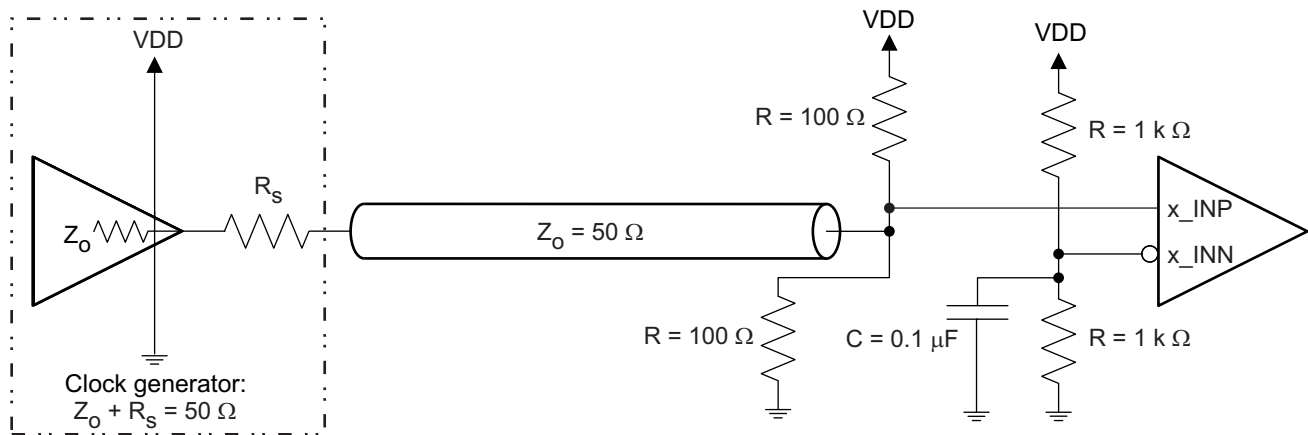

Figure 3. LVC MOS Input DC Configuration During Device Test

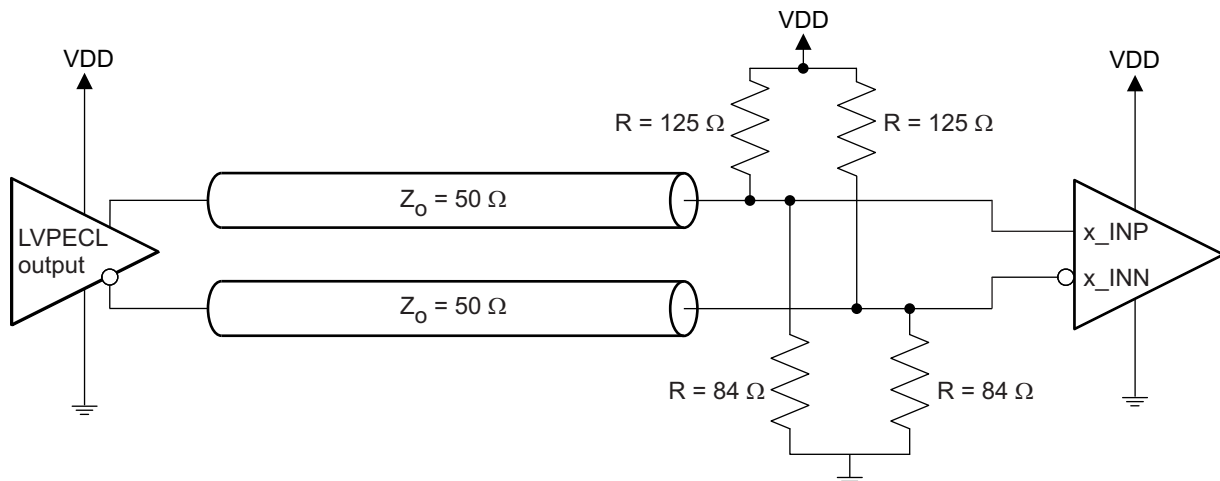

Figure 4. LVPECL Input Configuration During Device Test

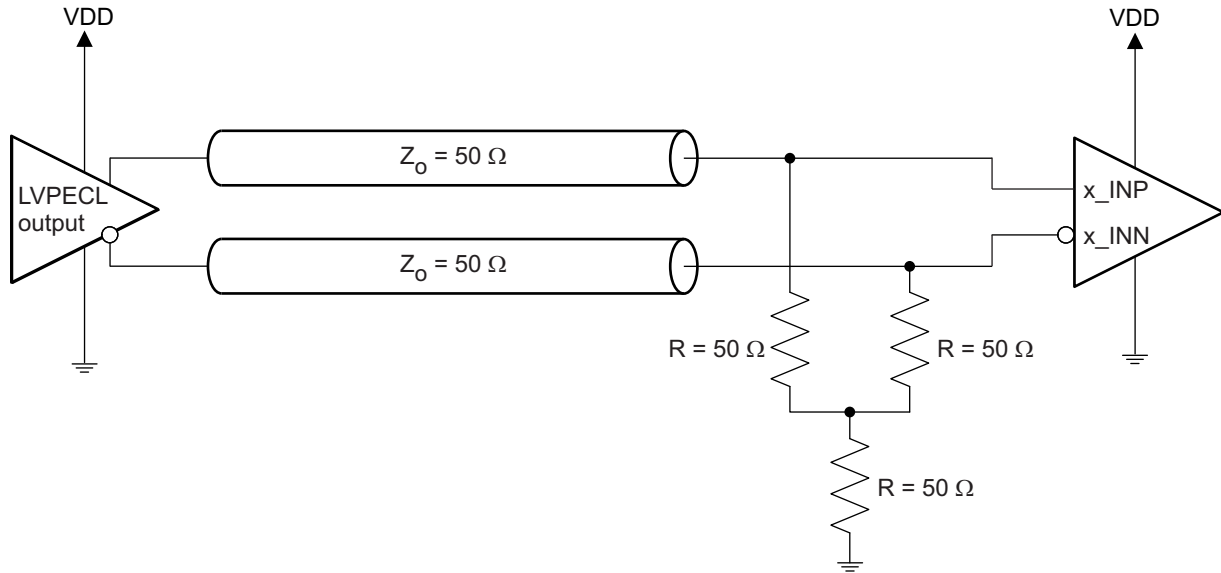

Figure 5. LVPECL Input Configuration During Device Test

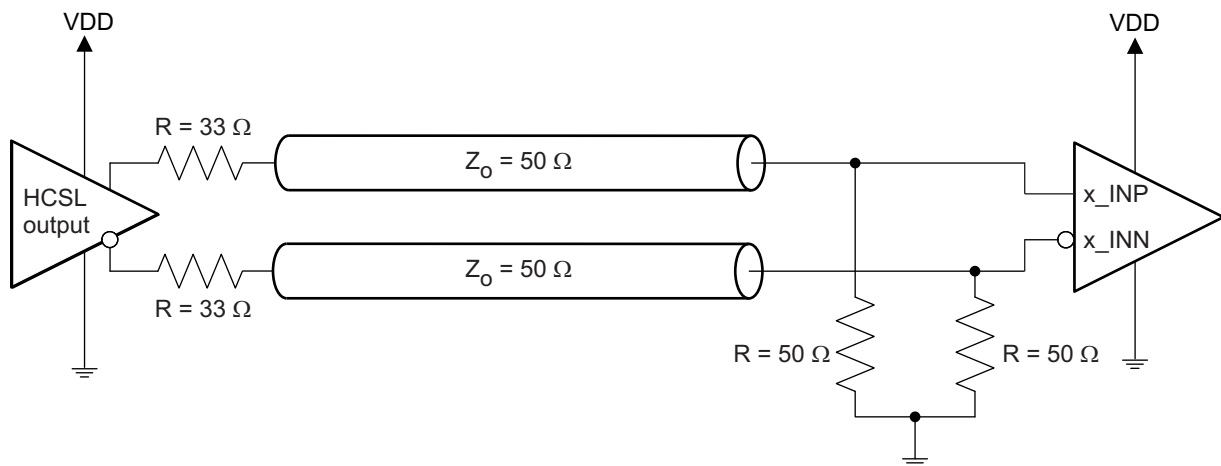

Figure 6. HCSL Input Configuration During Device Test

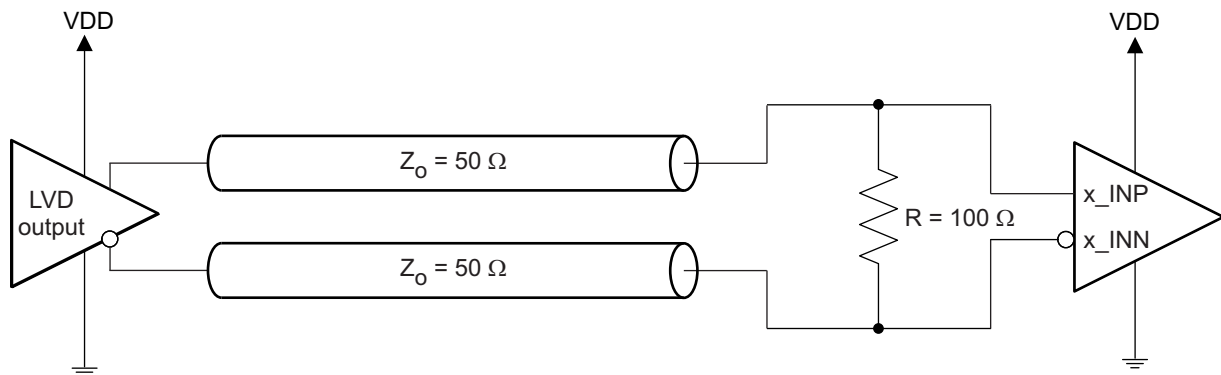

Figure 7. LVDS Input Configuration During Device Test

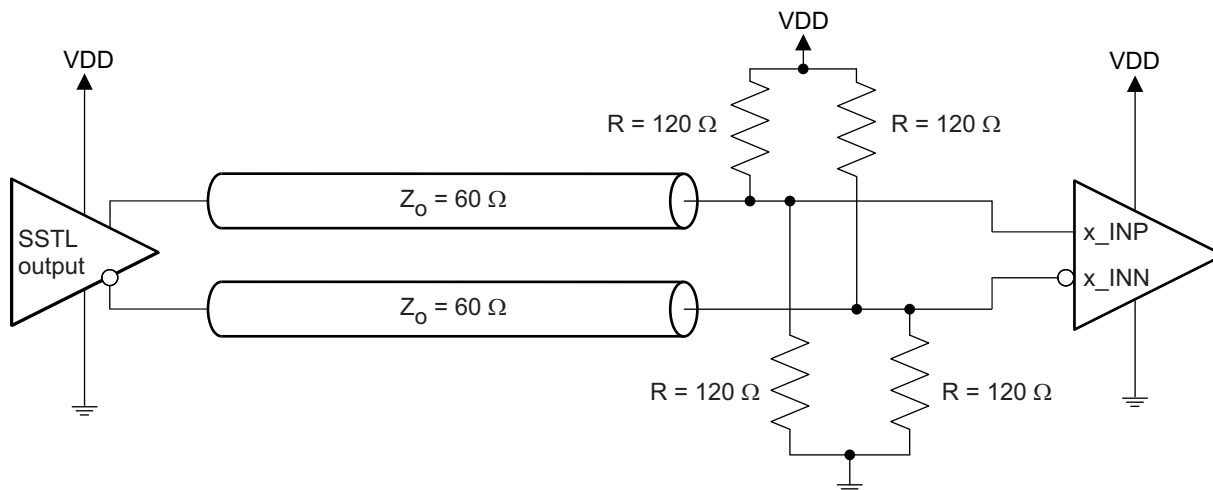

Figure 8. SSSL Input Configuration During Device Test

APPLICATION INFORMATION

Typical Application Load

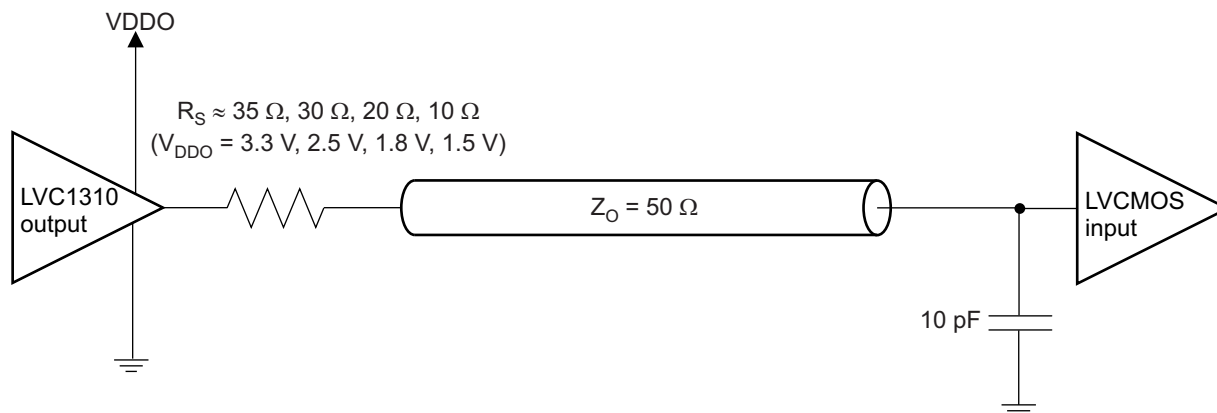

Figure 9. LVC1310 Output DC Configuration: Typical Application Load

Parameter Measurement Information

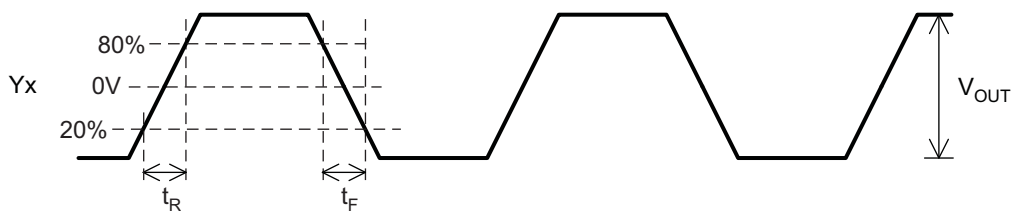

Figure 10. LVC1310 Output Voltage, and Rise and Fall Times

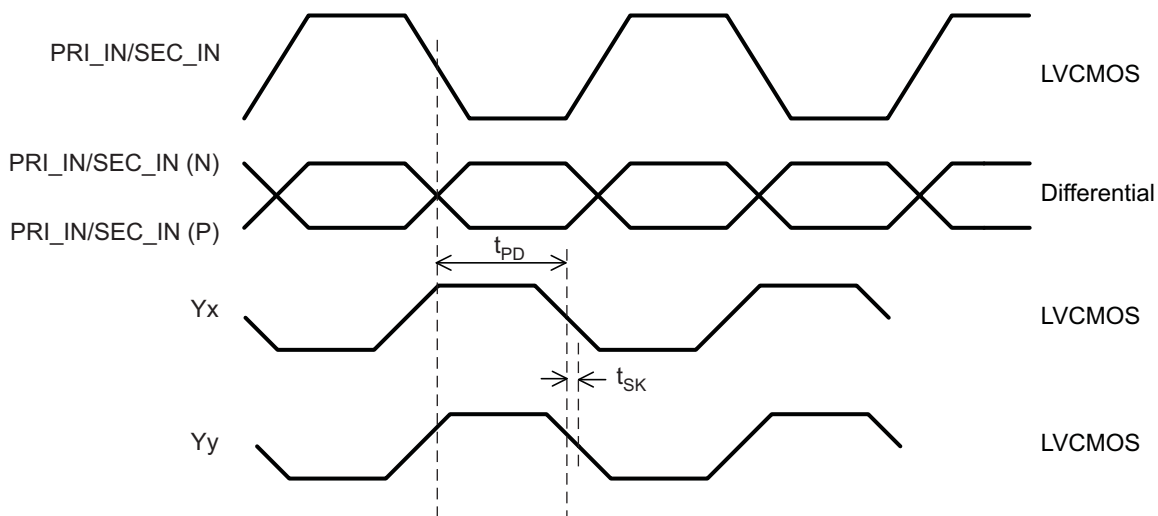
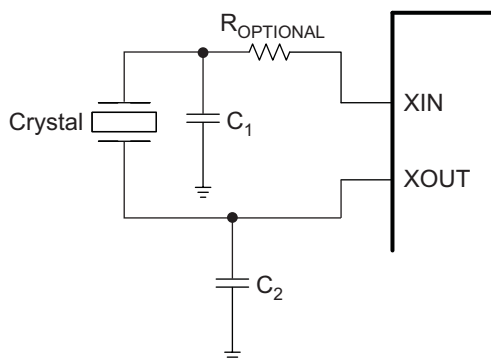

Figure 11. Differential and Single-Ended Output Skew and Propagation Delay

Crystal Oscillator Input

The crystal oscillator circuit is characterized with 18-pF parallel-resonant crystals. Choices of C1 and C2 were to minimize the ppm error. Optional resistor  $R_{OPTIONAL}$  limits the drive level of the oscillator circuit.

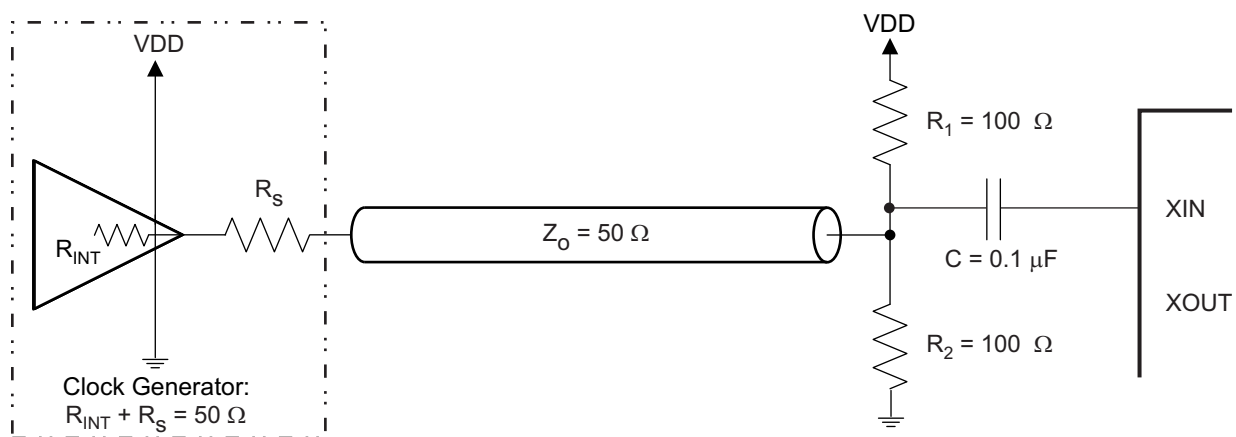

**Figure 12. Crystal Reference Input**

The input XIN can accept single-ended LVCMOS signals in two configurations. It is possible to overdrive the oscillator stage or to use a pure LVCMOS input (see [Table 1](#)). If overdriving the oscillator stage, it is necessary to ac-couple the input with a capacitor (see [Figure 13](#)). Otherwise, if selecting the bypass, there is no requirement for a coupling capacitor. Additional measurements and information about crystal oscillator input and limiting the drive level are available in the applications report *Crystal Oscillator Performance of the CDCLVC1310* ([SCAA119](#)).

**NOTE**

If using the overdrive or bypass mode, the device is functional, but may not meet its ac parameters.



**Figure 13. Single-Ended Crystal Input**

### Phase-Noise Performance

The CDCLVC1310 provides ultralow phase-noise outputs (noise floor =  $-170$  dBc/Hz) if it has an attached crystal. [Figure 14](#) shows the phase-noise plot of the CDCLVC1310 with a 25-MHz crystal at  $V_{DD} = V_{DDO} = 3.3$  V and room temperature.

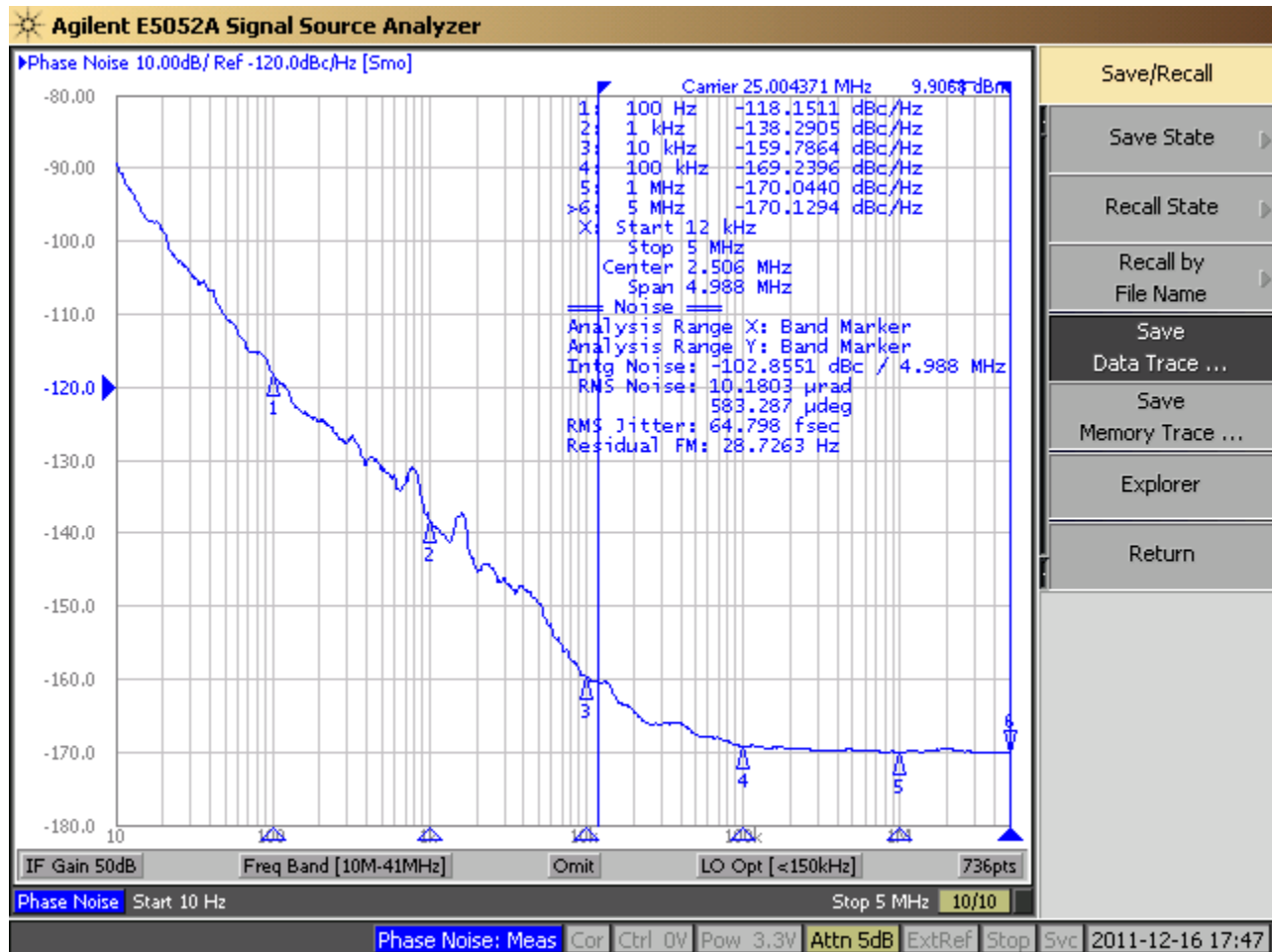

Figure 14. Phase-Noise Profile With 25-MHz Crystal at Nominal Conditions

### System-Level Additive-Jitter Measurement

For high-performance devices, limitations of the equipment influence phase-noise measurements. The noise floor of the equipment often exceeds the noise floor of the device. The real noise floor of the device is probably lower (see [LVC MOS Output Characteristics](#)). Phase noise is influenced by the input source and the measurement equipment. Additional measurements and information about system-level additive jitter and noise floor are available in the applications report *Phase Noise Performance of CDCLVC1310* (SCAA115).

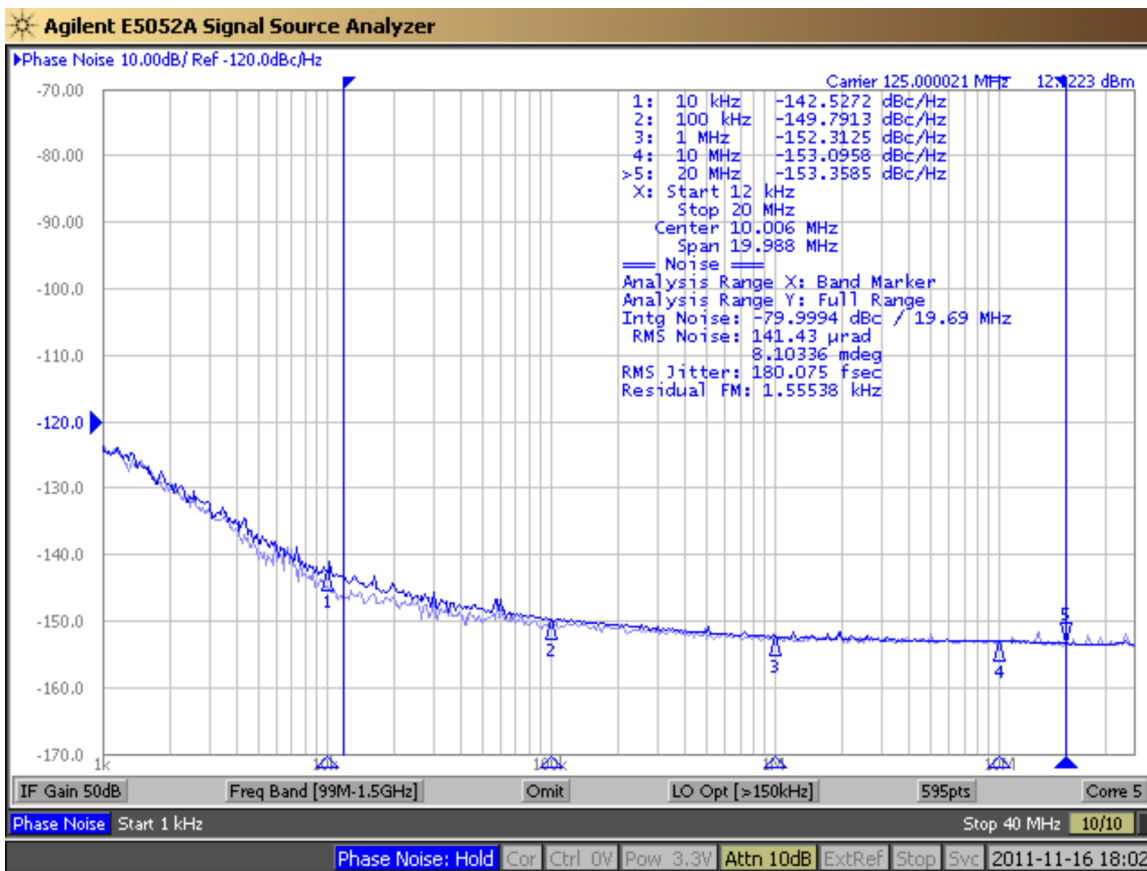

Figure 15. Input Phase Noise (179.4 fs, Light Blue) and Output Phase Noise (180 fs, Dark Blue)

### Output Enable

Pulling OE to LOW ( $t_1$ ), forces the outputs to the high-impedance state after the next falling edge of the input signal ( $t_2$ ). The outputs remain in the high-impedance state as long as OE is LOW (see Figure 16).

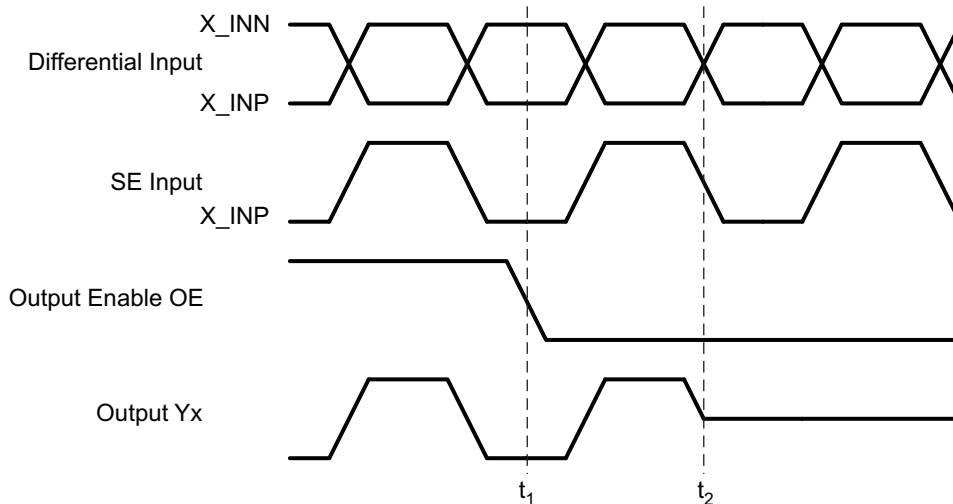

Figure 16. OE: Disable Outputs



If the outputs are in the high-impedance state, pulling OE to HIGH forces all outputs LOW asynchronously ( $t_3$ ). Within two clock cycles (maximum), the outputs start switching again ( $t_4$ ), after a falling edge of the input signal (see Figure 17).

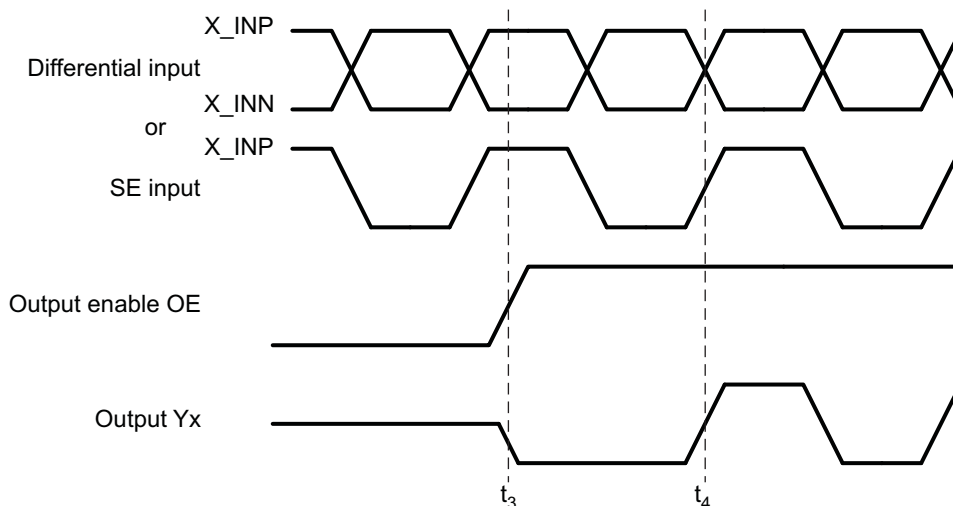

Figure 17. OE: Enable Outputs

If the outputs are in the high-impedance state and the input is static (no clock signal), OE works fully asynchronously. A transition of OE from LOW to HIGH forces the outputs to LOW. A transition from HIGH to LOW does not force to the high-impedance state again. Therefore, a state change requires a falling edge of the input signal (see Figure 16).

**MUX Isolation**

The definition of MUX isolation is the difference in output amplitude (dB) between an active and a static input signal.

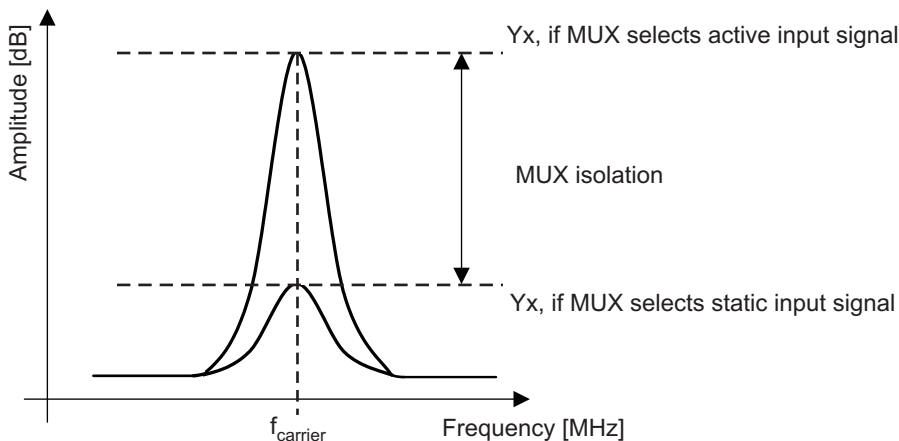
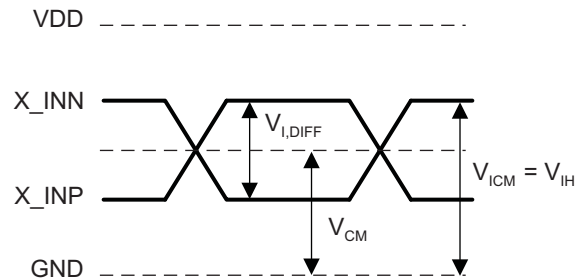

Figure 18. Output Spectrum of an Active and a Static Input Signal

## Differential Input Level



NOTE: The calculation for V<sub>CM</sub> is:  $V_{CM} = V_{DD} - V_{ICM} - V_{I,DIFF}/2$

**Figure 19. Differential Input Level**

## Power Considerations

The following power consideration refers to the device-consumed power consumption only. The device power consumption is the sum of static power and dynamic power. The dynamic power usage consists of two components:

- Power used by the device as it switches states
- Power required to charge any output load

The output load can be capacitive-only or capacitive and resistive. Use the following formula to calculate the power consumption of the device:

$$P_{Dev} = P_{stat} + P_{dyn} + P_{Cload} \text{ (see Figure 20 and Figure 21)}$$

$$P_{stat} = I_{DD} \times V_{DD}$$

$$P_{dyn} + P_{Cload} = (I_{DD,dyn} + I_{DD,Cload}) \times V_{DDO}$$

where:

$$I_{DD,dyn} = C_{PD} \times V_{DDO} \times f \times n \text{ [mA]} \text{ (see Figure 22)}$$

$$I_{DD,Cload} = C_{load} \times V_{DDO} \times f \times n \text{ [mA]}$$

Example for power consumption of the CDCLVC1310: 10 outputs are switching,  $f = 100 \text{ MHz}$ ,  $V_{DD} = V_{DDO} = 3.3 \text{ V}$  and assuming  $C_{load} = 2 \text{ pF}$  per output:

$$P_{Dev} = 46.2 \text{ mW} + 117.5 \text{ mW} = 163.7 \text{ mW}$$

$$P_{stat} = 14 \text{ mA} \times 3.3 \text{ V} = 46.2 \text{ mW}$$

$$P_{dyn} + P_{Cload} = (29 \text{ mA} + 6.6 \text{ mA}) \times 3.3 \text{ V} = 117.5 \text{ mW}$$

$$I_{DD,dyn} = 8.8 \text{ pF} \times 3.3 \text{ V} \times 100 \text{ MHz} \times 10 = 29 \text{ mA}$$

$$I_{DD,Cload} = 2 \text{ pF} \times 3.3 \text{ V} \times 100 \text{ MHz} \times 10 = 6.6 \text{ mA}$$

### NOTE

For dimensioning the power supply, consider the total power consumption. The total power consumption is the sum of device power consumption and the power consumption of the load.

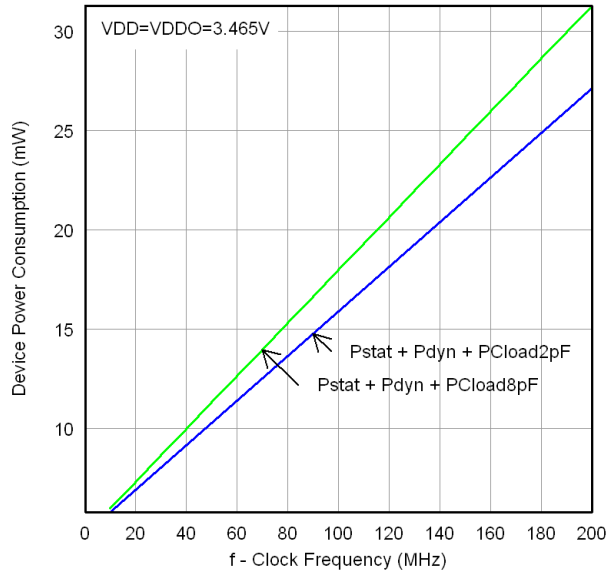

Figure 20. Device Power Consumption versus Clock Frequency (VDD = VDDO = 3.465 V; Load 2 pF, 8 pF; per Output)

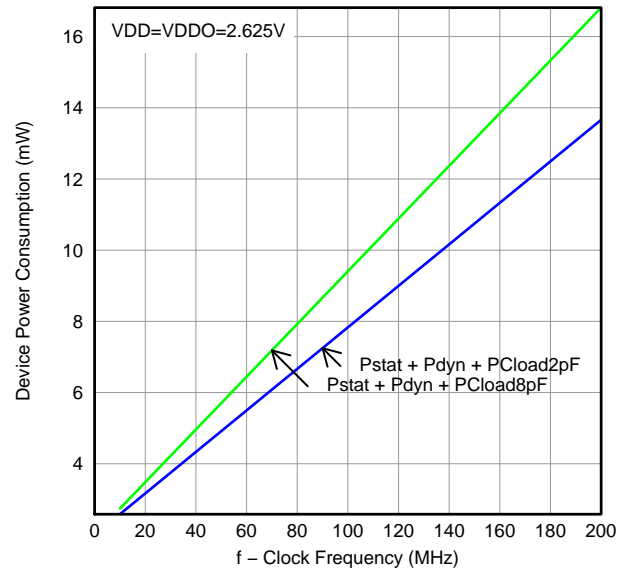

Figure 21. Device Power Consumption versus Clock Frequency (VDD = VDDO = 2.625 V; Load 2 pF, 8 pF; per Output)

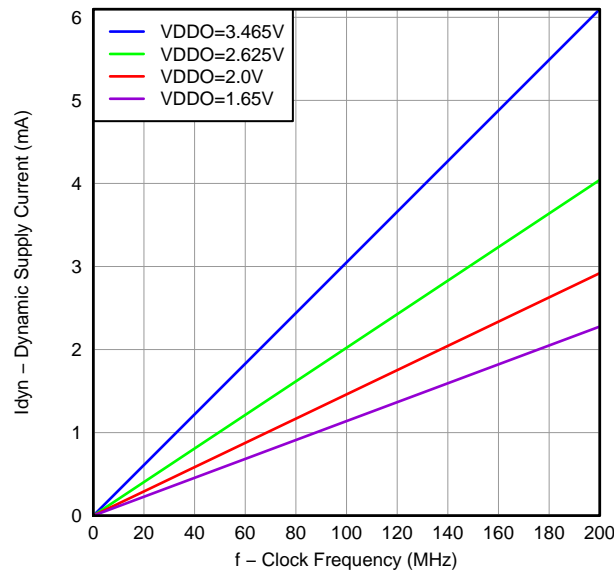

Figure 22. Dynamic Supply Current versus Clock Frequency (per Output)

## Thermal Management

Power consumption of the CDCLVC1310 can be high enough to require attention to thermal management. For reliability and performance reasons, limit the die temperature to a maximum of 125°C. That is, as an estimate,  $T_A$  (ambient temperature) plus device power consumption times  $\theta_{JA}$  should not exceed 125°C.

The device package has an exposed pad that provides the primary heat removal path as well as an electrical grounding to the printed circuit board (PCB). To maximize the removal of heat from the package, incorporate a thermal landing pattern including multiple vias to a ground plane on the PCB within the footprint of the package. Solder the exposed pad down to ensure adequate heat conduction out of the package. Figure 23 shows a recommended land and via pattern.

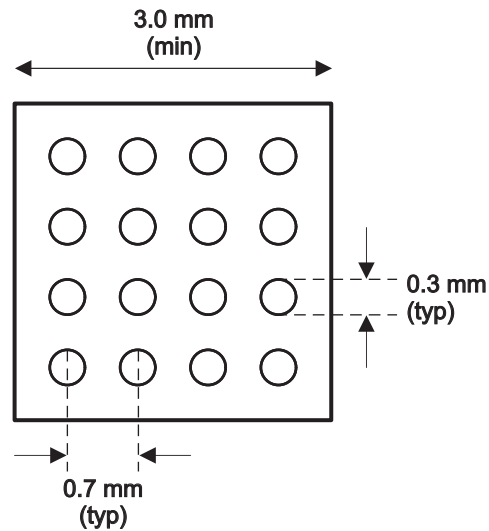
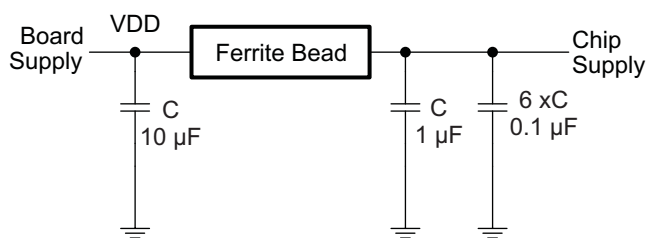

Figure 23. Recommended PCB Layout for CDCLVC1310

## Power-Supply Filtering

High-performance clock buffers are sensitive to noise on the power supply, which can dramatically increase the additive jitter of the buffer. Thus, it is essential to reduce noise from the system power supply, especially when jitter or phase noise is very critical to applications.

Use of filter capacitors eliminates the low-frequency noise from power supply, where the bypass capacitors provide the very low-impedance path for high-frequency noise and guard the power-supply system against induced fluctuations. The bypass capacitors also provide instantaneous current surges as required by the device, and should have low ESR. To use the bypass capacitors properly, place them very close to the power supply pins and lay out traces with short loops to minimize inductance. TI recommends to adding as many high-frequency (for example, 0.1- $\mu\text{F}$ ) bypass capacitors as there are supply pins in the package. There is a recommendation, but not a requirement, to insert a ferrite bead between the board power supply and the chip power supply to isolate the high-frequency switching noises generated by the clock driver, preventing them from leaking into the board supply. Choosing an appropriate ferrite bead with very low dc resistance is important, because it is imperative to provide adequate isolation between the board supply and the chip supply, and to maintain a voltage at the supply pins that is greater than the minimum voltage required for proper operation.



**Figure 24. Power-Supply Decoupling**

## REVISION HISTORY

<b>Changes from Revision D (July 2013) to Revision E</b>	<b>Page</b>
• Changed $V_{OH}$ in LVCMOS OUTPUT CHARACTERISTICS .....	7
• Changed $V_{OL}$ in LVCMOS OUTPUT CHARACTERISTICS .....	7
• Changed $t_{SLEW-RATE}$ in LVCMOS OUTPUT CHARACTERISTICS .....	7
<b>Changes from Revision C (October 2012) to Revision D</b>	
• Changed $t_{DELAY}$ in LVCMOS OUTPUT CHARACTERISTICS .....	8
<b>Changes from Revision B (February 2012) to Revision C</b>	
• Changed unit for phase jitter from picosecond to femtosecond .....	9
• Revised <a href="#">Figure 3</a> .....	10
• Revised <a href="#">Figure 4</a> .....	10
• Revised <a href="#">Figure 5</a> .....	11
• Revised <a href="#">Figure 6</a> .....	11
• Revised <a href="#">Figure 8</a> .....	12
• Added reference to application report SCAA119 .....	14

**PACKAGING INFORMATION**

Orderable Device	Status (1)	Package Type	Package Drawing	Pins	Package Qty	Eco Plan (2)	Lead/Ball Finish (6)	MSL Peak Temp (3)	Op Temp (°C)	Device Marking (4/5)	Samples
CDCLVC1310RHBR	ACTIVE	VQFN	RHB	32	3000	Green (RoHS & no Sb/Br)	CU NIPDAUAG	Level-2-260C-1 YEAR	-40 to 85	CDCLVC 1310	Samples

(1) The marketing status values are defined as follows:

**ACTIVE:** Product device recommended for new designs.

**LIFEBUY:** TI has announced that the device will be discontinued, and a lifetime-buy period is in effect.

**NRND:** Not recommended for new designs. Device is in production to support existing customers, but TI does not recommend using this part in a new design.

**PREVIEW:** Device has been announced but is not in production. Samples may or may not be available.

**OBSELETE:** TI has discontinued the production of the device.

(2) Eco Plan - The planned eco-friendly classification: Pb-Free (RoHS), Pb-Free (RoHS Exempt), or Green (RoHS & no Sb/Br) - please check <http://www.ti.com/productcontent> for the latest availability information and additional product content details.

**TBD:** The Pb-Free/Green conversion plan has not been defined.

**Pb-Free (RoHS):** TI's terms "Lead-Free" or "Pb-Free" mean semiconductor products that are compatible with the current RoHS requirements for all 6 substances, including the requirement that lead not exceed 0.1% by weight in homogeneous materials. Where designed to be soldered at high temperatures, TI Pb-Free products are suitable for use in specified lead-free processes.

**Pb-Free (RoHS Exempt):** This component has a RoHS exemption for either 1) lead-based flip-chip solder bumps used between the die and package, or 2) lead-based die adhesive used between the die and leadframe. The component is otherwise considered Pb-Free (RoHS compatible) as defined above.

**Green (RoHS & no Sb/Br):** TI defines "Green" to mean Pb-Free (RoHS compatible), and free of Bromine (Br) and Antimony (Sb) based flame retardants (Br or Sb do not exceed 0.1% by weight in homogeneous material)

(3) MSL, Peak Temp. - The Moisture Sensitivity Level rating according to the JEDEC industry standard classifications, and peak solder temperature.

(4) There may be additional marking, which relates to the logo, the lot trace code information, or the environmental category on the device.

(5) Multiple Device Markings will be inside parentheses. Only one Device Marking contained in parentheses and separated by a "~" will appear on a device. If a line is indented then it is a continuation of the previous line and the two combined represent the entire Device Marking for that device.

(6) Lead/Ball Finish - Orderable Devices may have multiple material finish options. Finish options are separated by a vertical ruled line. Lead/Ball Finish values may wrap to two lines if the finish value exceeds the maximum column width.

**Important Information and Disclaimer:** The information provided on this page represents TI's knowledge and belief as of the date that it is provided. TI bases its knowledge and belief on information provided by third parties, and makes no representation or warranty as to the accuracy of such information. Efforts are underway to better integrate information from third parties. TI has taken and continues to take reasonable steps to provide representative and accurate information but may not have conducted destructive testing or chemical analysis on incoming materials and chemicals. TI and TI suppliers consider certain information to be proprietary, and thus CAS numbers and other limited information may not be available for release.

In no event shall TI's liability arising out of such information exceed the total purchase price of the TI part(s) at issue in this document sold by TI to Customer on an annual basis.





## TAPE AND REEL INFORMATION



### QUADRANT ASSIGNMENTS FOR PIN 1 ORIENTATION IN TAPE



\*All dimensions are nominal

Device	Package Type	Package Drawing	Pins	SPQ	Reel Diameter (mm)	Reel Width W1 (mm)	A0 (mm)	B0 (mm)	K0 (mm)	P1 (mm)	W (mm)	Pin1 Quadrant
CDCLVC1310RHBR	VQFN	RHB	32	3000	330.0	12.4	5.3	5.3	1.5	8.0	12.0	Q2

TAPE AND REEL BOX DIMENSIONS



\*All dimensions are nominal

Device	Package Type	Package Drawing	Pins	SPQ	Length (mm)	Width (mm)	Height (mm)
CDCLVC1310RHBR	VQFN	RHB	32	3000	367.0	367.0	35.0



## THERMAL INFORMATION

This package incorporates an exposed thermal pad that is designed to be attached directly to an external heatsink. The thermal pad must be soldered directly to the printed circuit board (PCB). After soldering, the PCB can be used as a heatsink. In addition, through the use of thermal vias, the thermal pad can be attached directly to the appropriate copper plane shown in the electrical schematic for the device, or alternatively, can be attached to a special heatsink structure designed into the PCB. This design optimizes the heat transfer from the integrated circuit (IC).

For information on the Quad Flatpack No-Lead (QFN) package and its advantages, refer to Application Report, QFN/SON PCB Attachment, Texas Instruments Literature No. SLUA271. This document is available at [www.ti.com](http://www.ti.com).

The exposed thermal pad dimensions for this package are shown in the following illustration.

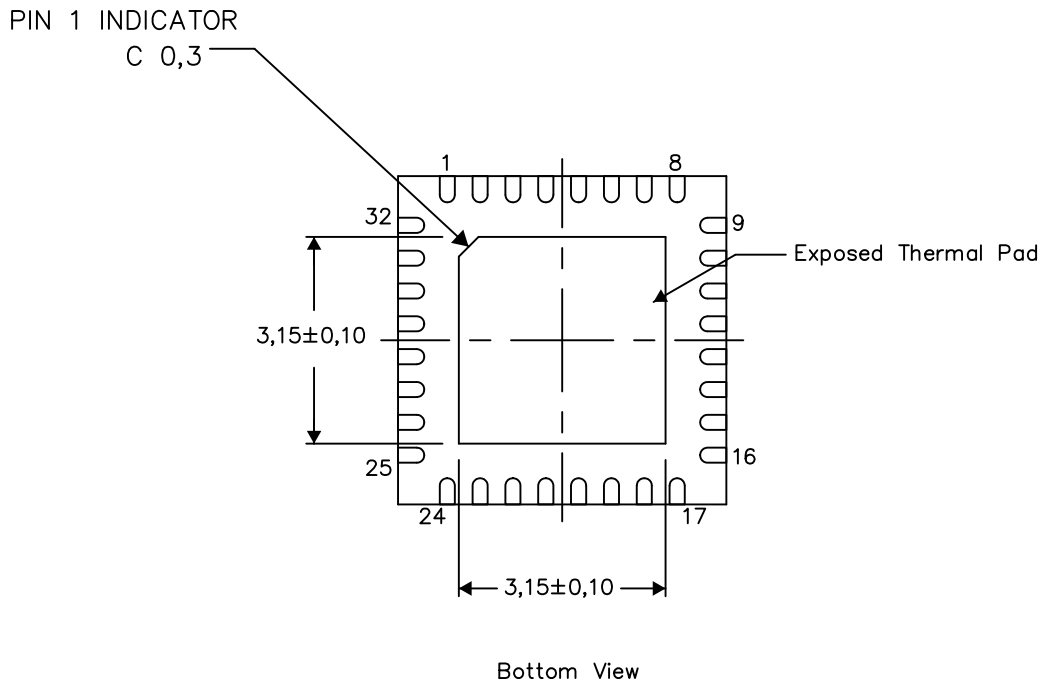

Exposed Thermal Pad Dimensions

4206356-3/Y 06/13

NOTE: A. All linear dimensions are in millimeters



## IMPORTANT NOTICE

Texas Instruments Incorporated and its subsidiaries (TI) reserve the right to make corrections, enhancements, improvements and other changes to its semiconductor products and services per JESD46, latest issue, and to discontinue any product or service per JESD48, latest issue. Buyers should obtain the latest relevant information before placing orders and should verify that such information is current and complete. All semiconductor products (also referred to herein as "components") are sold subject to TI's terms and conditions of sale supplied at the time of order acknowledgment.

TI warrants performance of its components to the specifications applicable at the time of sale, in accordance with the warranty in TI's terms and conditions of sale of semiconductor products. Testing and other quality control techniques are used to the extent TI deems necessary to support this warranty. Except where mandated by applicable law, testing of all parameters of each component is not necessarily performed.

TI assumes no liability for applications assistance or the design of Buyers' products. Buyers are responsible for their products and applications using TI components. To minimize the risks associated with Buyers' products and applications, Buyers should provide adequate design and operating safeguards.

TI does not warrant or represent that any license, either express or implied, is granted under any patent right, copyright, mask work right, or other intellectual property right relating to any combination, machine, or process in which TI components or services are used. Information published by TI regarding third-party products or services does not constitute a license to use such products or services or a warranty or endorsement thereof. Use of such information may require a license from a third party under the patents or other intellectual property of the third party, or a license from TI under the patents or other intellectual property of TI.

Reproduction of significant portions of TI information in TI data books or data sheets is permissible only if reproduction is without alteration and is accompanied by all associated warranties, conditions, limitations, and notices. TI is not responsible or liable for such altered documentation. Information of third parties may be subject to additional restrictions.

Resale of TI components or services with statements different from or beyond the parameters stated by TI for that component or service voids all express and any implied warranties for the associated TI component or service and is an unfair and deceptive business practice. TI is not responsible or liable for any such statements.

Buyer acknowledges and agrees that it is solely responsible for compliance with all legal, regulatory and safety-related requirements concerning its products, and any use of TI components in its applications, notwithstanding any applications-related information or support that may be provided by TI. Buyer represents and agrees that it has all the necessary expertise to create and implement safeguards which anticipate dangerous consequences of failures, monitor failures and their consequences, lessen the likelihood of failures that might cause harm and take appropriate remedial actions. Buyer will fully indemnify TI and its representatives against any damages arising out of the use of any TI components in safety-critical applications.

In some cases, TI components may be promoted specifically to facilitate safety-related applications. With such components, TI's goal is to help enable customers to design and create their own end-product solutions that meet applicable functional safety standards and requirements. Nonetheless, such components are subject to these terms.

No TI components are authorized for use in FDA Class III (or similar life-critical medical equipment) unless authorized officers of the parties have executed a special agreement specifically governing such use.

Only those TI components which TI has specifically designated as military grade or "enhanced plastic" are designed and intended for use in military/aerospace applications or environments. Buyer acknowledges and agrees that any military or aerospace use of TI components which have **not** been so designated is solely at the Buyer's risk, and that Buyer is solely responsible for compliance with all legal and regulatory requirements in connection with such use.

TI has specifically designated certain components as meeting ISO/TS16949 requirements, mainly for automotive use. In any case of use of non-designated products, TI will not be responsible for any failure to meet ISO/TS16949.

### Products

Audio	<a href="http://www.ti.com/audio">www.ti.com/audio</a>
Amplifiers	<a href="http://amplifier.ti.com">amplifier.ti.com</a>
Data Converters	<a href="http://dataconverter.ti.com">dataconverter.ti.com</a>
DLP® Products	<a href="http://www.dlp.com">www.dlp.com</a>
DSP	<a href="http://dsp.ti.com">dsp.ti.com</a>
Clocks and Timers	<a href="http://www.ti.com/clocks">www.ti.com/clocks</a>
Interface	<a href="http://interface.ti.com">interface.ti.com</a>
Logic	<a href="http://logic.ti.com">logic.ti.com</a>
Power Mgmt	<a href="http://power.ti.com">power.ti.com</a>
Microcontrollers	<a href="http://microcontroller.ti.com">microcontroller.ti.com</a>
RFID	<a href="http://www.ti-rfid.com">www.ti-rfid.com</a>
OMAP Applications Processors	<a href="http://www.ti.com/omap">www.ti.com/omap</a>
Wireless Connectivity	<a href="http://www.ti.com/wirelessconnectivity">www.ti.com/wirelessconnectivity</a>

### Applications

Automotive and Transportation	<a href="http://www.ti.com/automotive">www.ti.com/automotive</a>
Communications and Telecom	<a href="http://www.ti.com/communications">www.ti.com/communications</a>
Computers and Peripherals	<a href="http://www.ti.com/computers">www.ti.com/computers</a>
Consumer Electronics	<a href="http://www.ti.com/consumer-apps">www.ti.com/consumer-apps</a>
Energy and Lighting	<a href="http://www.ti.com/energy">www.ti.com/energy</a>
Industrial	<a href="http://www.ti.com/industrial">www.ti.com/industrial</a>
Medical	<a href="http://www.ti.com/medical">www.ti.com/medical</a>
Security	<a href="http://www.ti.com/security">www.ti.com/security</a>
Space, Avionics and Defense	<a href="http://www.ti.com/space-avionics-defense">www.ti.com/space-avionics-defense</a>
Video and Imaging	<a href="http://www.ti.com/video">www.ti.com/video</a>

### TI E2E Community

[e2e.ti.com](http://e2e.ti.com)