

LOC	DIST	P	F	ZONE	LTR	DESCRIPTION	DATE	APPD
GP	00					D REVISED PER EC 0513-0205-03	21AUG03	JG

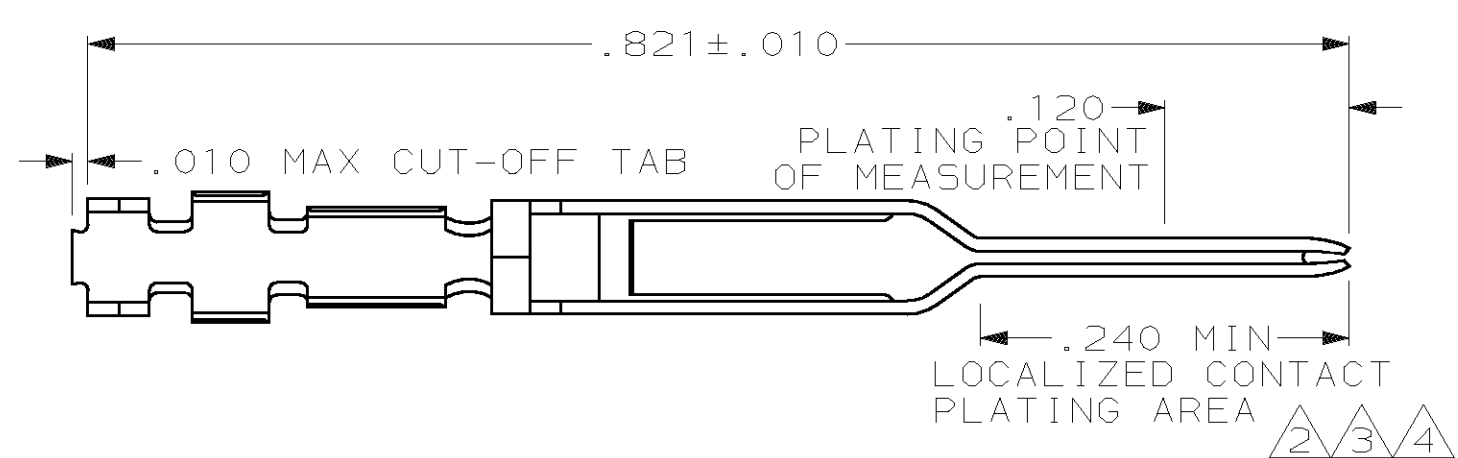

- ① FINISH: .000100 MIN THK BRIGHT TIN LEAD OVER .000050 MIN THK NICKEL ON ENTIRE CONTACT.
- ② FINISH: .000015 THK GOLD IN LOCALIZED CONTACT PLATING AREA AND GOLD FLASH IN OTHER AREAS OVER .000050 MIN NICKEL ON ENTIRE CONTACT.
- ③ FINISH: .000030 THK GOLD IN LOCALIZED CONTACT PLATING AREA AND GOLD FLASH IN OTHER AREAS OVER .000050 MIN NICKEL ON ENTIRE CONTACT.
- ④ FINISH: .000050 THK GOLD IN LOCALIZED CONTACT PLATING AREA AND GOLD FLASH IN OTHER AREAS OVER .000050 MIN NICKEL ON ENTIRE CONTACT.
- 5. FOR 22-26 AWG WIRE WITH AN INSULATION RANGE OF .040-.056 DIA.
- ⑥ FINISH: .000100 MIN THK TIN OVER .000050 MIN THK NICKEL ON ENTIRE CONTACT.

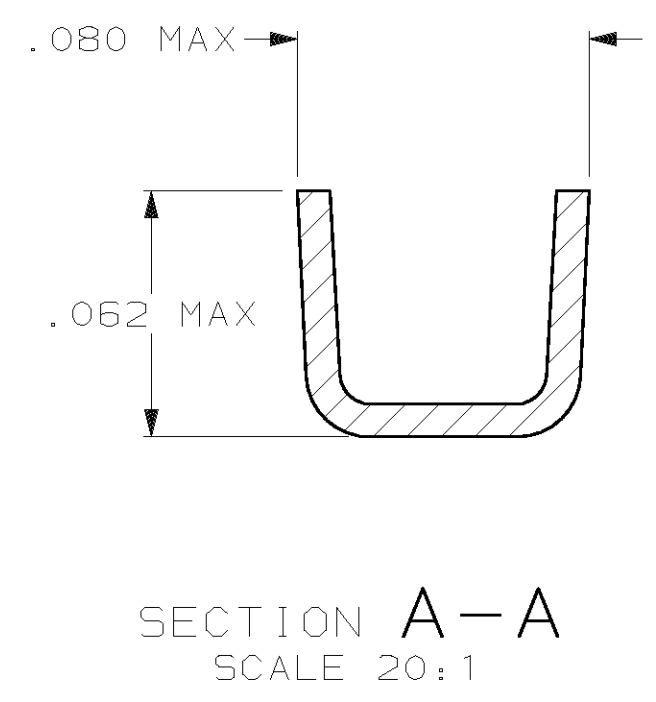
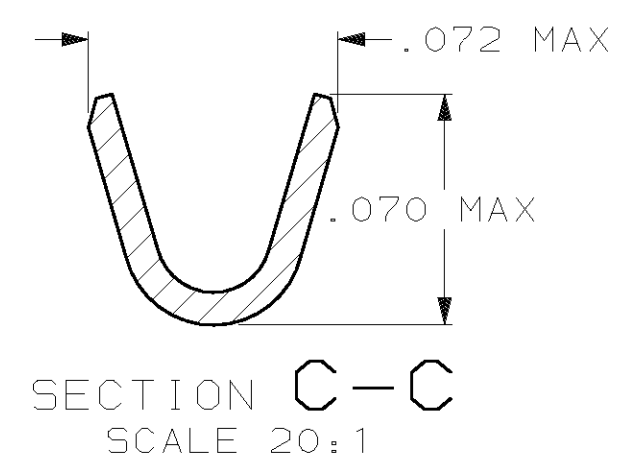
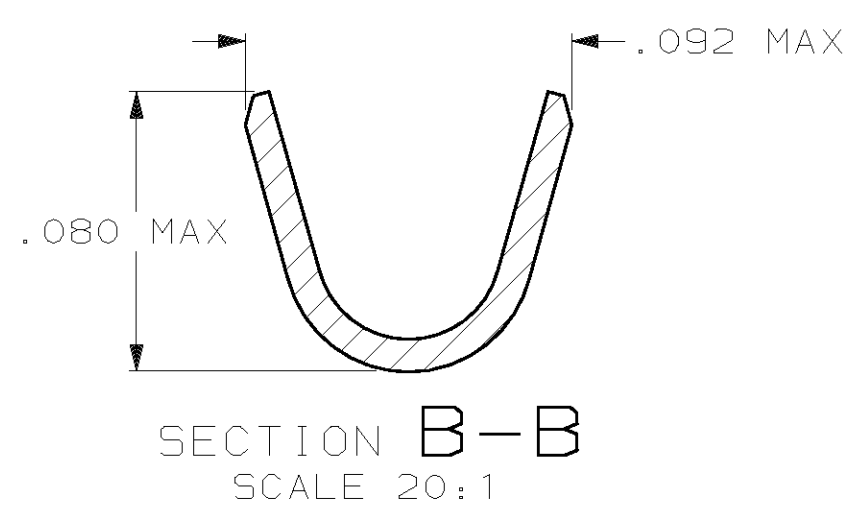
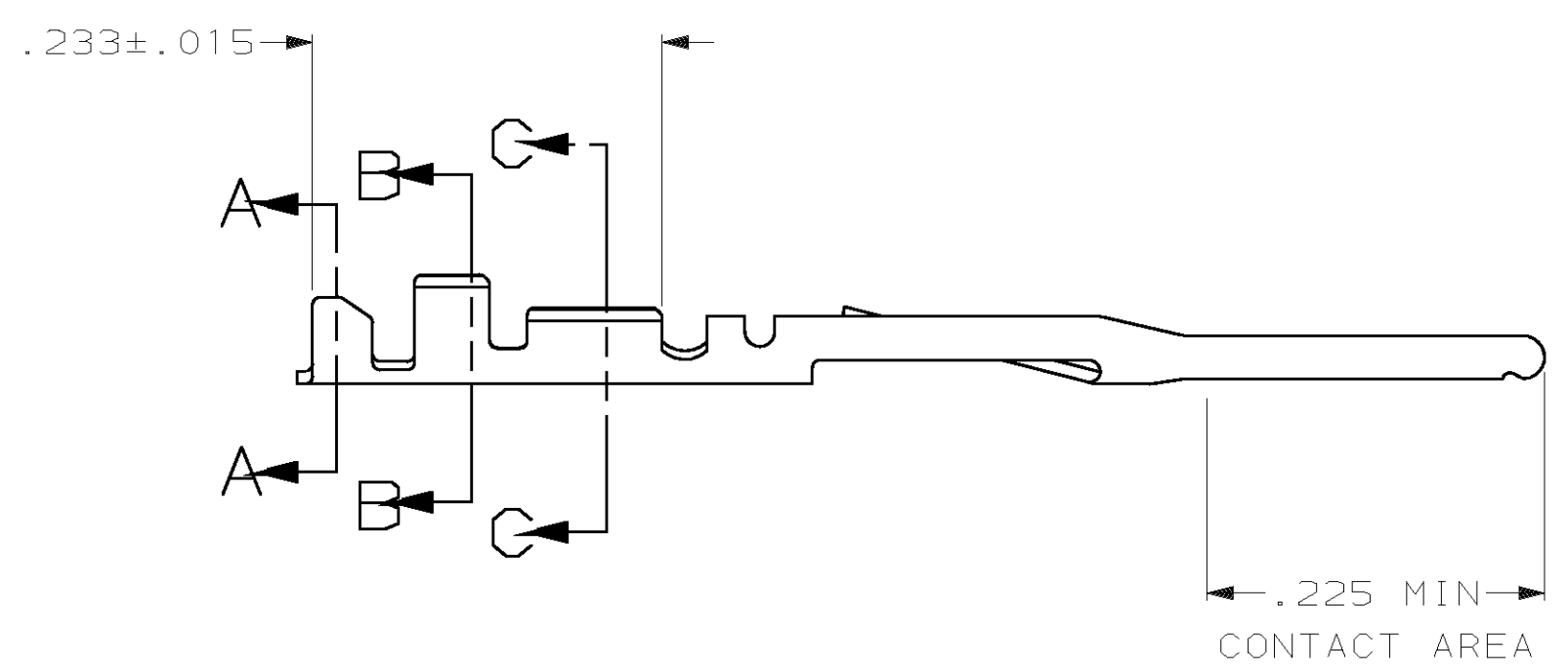

FINISH	REELED PART NO	PART NO
⑥	1-86557-9	1-86561-0
①	1-86557-4	86561-9
④	86557-7	86561-7
②	86557-6	86561-6
③	86557-4	86561-4

DO NOT SCALE PRINT. UNLESS SPECIFIED DIMENSIONS IN INCHES TOLERANCES ON : 2 PLC DEC ± - 3 PLC DEC ± .005 ANGLES ± -		DR 6-27-89 J. GALLUCCI		AMP INCORPORATED Harrisburg, Pa. 17105	
MATERIAL PHOS. BRONZE		CHK 6-28-89 D.L. ROCKER			
FINISH SEE TABLE		APPD 6-29-89 G.D. MILLER		NAME CONTACT, PIN, .025 SQ ROUND WIRE, .100¢, FFC	
		APPD 6-29-89 W.T. PAREKER		DRAWING NO 86561	
		PRODUCT SPEC 108-9024		SIZE C 00779	
		APPLICATION SPEC 114-16003		SCALE 8:1	
		WEIGHT -		SHEET 1 OF 1	