

DS34C86T

DS34C86T Quad CMOS Differential Line Receiver



Literature Number: SNLS379B

DS34C86T

Quad CMOS Differential Line Receiver

General Description

The DS34C86T is a quad differential line receiver designed to meet the RS-422, RS-423, and Federal Standards 1020 and 1030 for balanced and unbalanced digital data transmission, while retaining the low power characteristics of CMOS.

The DS34C86T has an input sensitivity of 200 mV over the common mode input voltage range of $\pm 7V$. Hysteresis is provided to improve noise margin and discourage output instability for slowly changing input waveforms.

The DS34C86T features internal pull-up and pull-down resistors which prevent output oscillation on unused channels.

Separate enable pins allow independent control of receiver pairs. The TRI-STATE[®] outputs have 6 mA source and sink capability. The DS34C86T is pin compatible with the DS3486.

Features

- CMOS design for low power
- $\pm 0.2V$ sensitivity over the input common mode voltage range
- Typical propagation delays: 19 ns
- Typical input hysteresis: 60 mV
- Inputs won't load line when $V_{CC} = 0V$
- Meets the requirements of EIA standard RS-422
- TRI-STATE outputs for system bus compatibility
- Available in surface mount
- Open input Failsafe feature, output high for open input

Logic Diagram

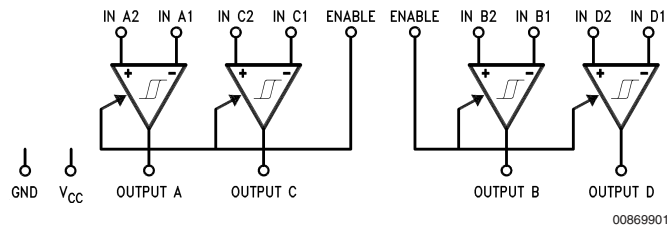

Connection Diagram

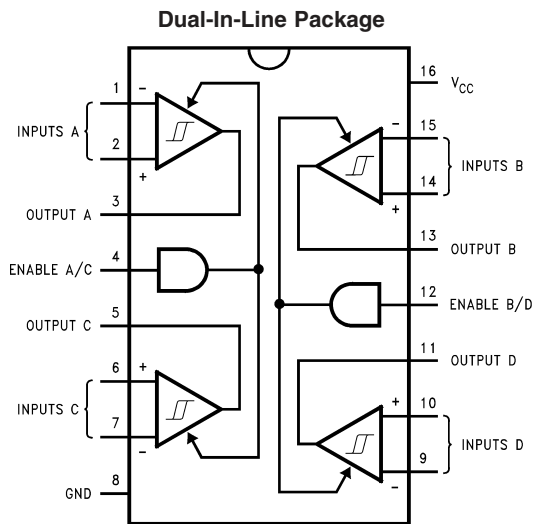

Top View

Order Number DS34C86TM, and DS34C86TN
See NS Package Number M16A and N16E

Truth Table

Enable	Input	Output
L	X	Z
H	$V_{ID} \geq V_{TH} (\text{Max})$	H
H	$V_{ID} \leq V_{TH} (\text{Min})$	L
H	Open*	H

*Open, not terminated
Z = TRI-STATE

TRI-STATE[®] is a registered trademark of National Semiconductor Corporation.

Absolute Maximum Ratings (Notes 1,

2)

If Military/Aerospace specified devices are required, please contact the National Semiconductor Sales Office/Distributors for availability and specifications.

Supply Voltage (V_{CC})	7V
Input Common Mode Range (V_{CM})	$\pm 14V$
Differential Input Voltage (V_{DIFF})	$\pm 14V$
Enable Input Voltage (V_{IN})	7V
Storage Temperature Range (T_{STG})	$-65^{\circ}C$ to $+150^{\circ}C$
Lead Temperature (Soldering 4 sec)	$260^{\circ}C$

Maximum Power Dissipation at $25^{\circ}C$ (Note 5)

Plastic "N" Package	1645 mW
SOIC Package	1190 mW
Current Per Output	± 25 mA

This device does not meet 2000V ESD rating. (Note 4)

Operating Conditions

	Min	Max	Unit
Supply Voltage (V_{CC})	4.50	5.50	V
Operating Temperature Range (T_A)	-40	$+85$	$^{\circ}C$
Enable Input Rise or Fall Times		500	ns

DC Electrical Characteristics (Note 3)

$V_{CC} = 5V \pm 10\%$ (unless otherwise specified)

Symbol	Parameter	Conditions	Min	Typ	Max	Units
V_{TH}	Minimum Differential Input Voltage	$V_{OUT} = V_{OH}$ or V_{OL} $-7V < V_{CM} < +7V$	-200	35	+200	mV
R_{IN}	Input Resistance	$V_{IN} = -7V, +7V$ (Other Input = GND)	5.0	6.8	10	k Ω
I_{IN}	Input Current (Under Test)	$V_{IN} = +10V$, Other Input = GND $V_{IN} = -10V$, Other Input = GND		+1.1 -2.0	+1.5 -2.5	mA
V_{OH}	Minimum High Level Output Voltage	$V_{CC} = \text{Min.}$, $V_{(DIFF)} = +1V$ $I_{OUT} = -6.0$ mA	3.8	4.2		V
V_{OL}	Maximum Low Level Output Voltage	$V_{CC} = \text{Max.}$, $V_{(DIFF)} = -1V$ $I_{OUT} = 6.0$ mA		0.2	0.3	V
V_{IH}	Minimum Enable High Input Level Voltage		2.0			V
V_{IL}	Maximum Enable Low Input Level Voltage				0.8	V
I_{OZ}	Maximum TRI-STATE Output Leakage Current	$V_{OUT} = V_{CC}$ or GND, TRI-STATE Control = V_{IL}		± 0.5	± 5.0	μA
I_I	Maximum Enable Input Current	$V_{IN} = V_{CC}$ or GND			± 1.0	μA
I_{CC}	Quiescent Power Supply Current	$V_{CC} = \text{Max.}$, $V_{(DIFF)} = +1V$		16	23	mA
V_{HYST}	Input Hysteresis	$V_{CM} = 0V$		60		mV

AC Electrical Characteristics (Note 3)

$V_{CC} = 5V \pm 10\%$ (unless otherwise specified) (Figures 1, 2, 3)

Symbol	Parameter	Conditions	Min	Typ	Max	Units
t_{PLH} , t_{PHL}	Propagation Delay Input to Output	$C_L = 50$ pF $V_{DIFF} = 2.5V$ $V_{CM} = 0V$		19	30	ns
t_{RISE} , t_{FALL}	Output Rise and Fall Times	$C_L = 50$ pF $V_{DIFF} = 2.5V$ $V_{CM} = 0V$		4	9	ns
t_{PLZ} , t_{PHZ}	Propagation Delay ENABLE to Output	$C_L = 50$ pF $R_L = 1000\Omega$		13	18	ns

AC Electrical Characteristics (Note 3) (Continued) $V_{CC} = 5V \pm 10\%$ (unless otherwise specified) (Figures 1, 2, 3)

Symbol	Parameter	Conditions	Min	Typ	Max	Units
		$V_{DIFF} = 2.5V$				
t_{PZL} t_{PZH}	Propagation Delay ENABLE to Output	$C_L = 50 \text{ pF}$ $R_L = 1000\Omega$ $V_{DIFF} = 2.5V$		13	21	ns

Note 1: Absolute Maximum Ratings are those values beyond which the safety of the device cannot be guaranteed. They are not meant to imply that the device should be operated at these limits. The table of "Electrical Characteristics" provides conditions for actual device operation.

Note 2: Unless otherwise specified, all voltages are referenced to ground.

Note 3: Unless otherwise specified, Min/Max limits apply across the operating temperature range.

All typicals are given for $V_{CC} = 5V$ and $T_A = 25^\circ\text{C}$.

Note 4: ESD Rating; HBM (1.5k Ω , 100 pF)

Inputs $\geq 2000V$

All other pins $\geq 1000V$

EIAJ (0 Ω , 200 pF) $\geq 350V$

Note 5: Ratings apply to ambient temperature at 25°C . Above this temperature derate N Package 13.16 mW/ $^\circ\text{C}$, and M Package 9.52 mW/ $^\circ\text{C}$.

Comparison Table of Switching Characteristics into "LS-Type" Load (Note 6) $V_{CC} = 5V$, $T_A = 25^\circ\text{C}$ (Figures 4, 5)

Symbol	Parameter	DS34C86		DS3486		Units
		Typ	Max	Typ	Max	
$t_{PHL(D)}$	Propagation Delay Time Output High to Low	17		19		ns
$t_{PLH(D)}$	Propagation Delay Time Output Low to High	19		19		ns
t_{PLZ}	Output Low to TRI-STATE	13		23		ns
t_{PHZ}	Output High to TRI-STATE	12		25		ns
t_{PZH}	Output TRI-STATE to High	13		18		ns
t_{PZL}	Output TRI-STATE to Low	13		20		ns

Note 6: This Table is provided for comparison purposes only. The values in this table for the DS34C86 reflect the performance of the device but are not tested or guaranteed.

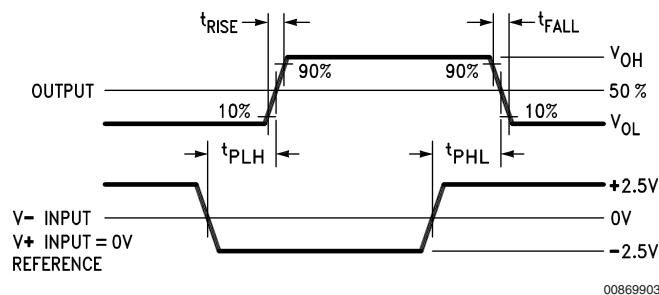
Test and Switching Waveforms**FIGURE 1. Propagation Delays**

Test and Switching Waveforms (Continued)

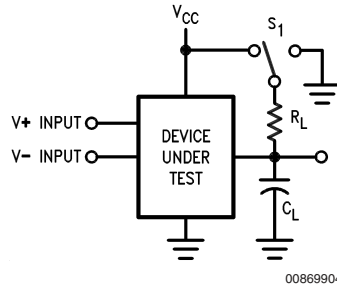

00869904

C_L Includes load and test jig capacitance.
 $S_1 = V_{CC}$ for t_{PZL} , and t_{PLZ} measurements.
 $S_1 = GND$ for t_{PZH} , and t_{PHZ} measurements.

FIGURE 2. Test Circuit for TRI-STATE Output Tests

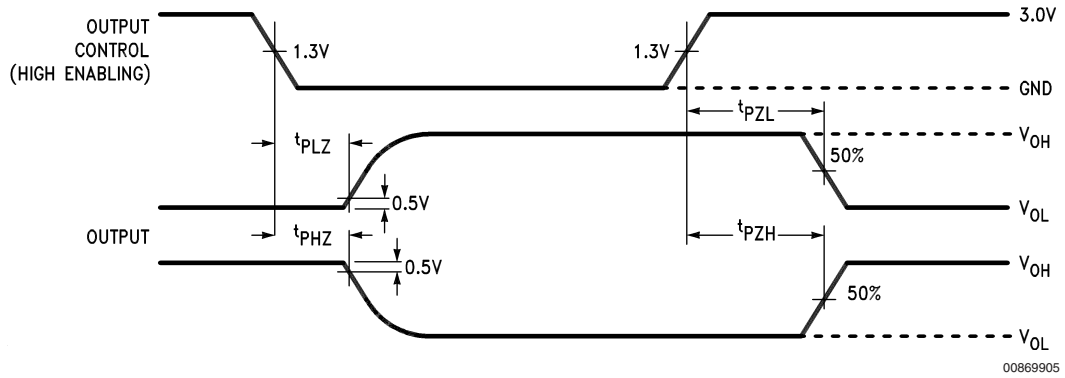

00869905

FIGURE 3. TRI-STATE Output Enable and Disable Waveforms

AC Test Circuits and Switching Time Waveforms

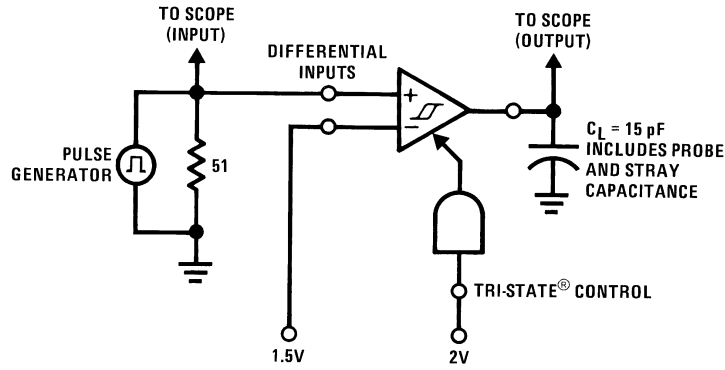

00869906

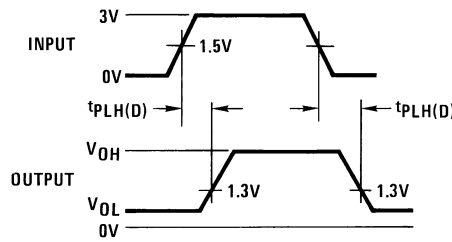

00869907

Input Pulse Characteristics:
 $t_{TLH} = t_{THL} = 6\text{ ns}$ (10% to 90%)
 PRR = 1 MHz, 50% duty cycle

FIGURE 4. Propagation Delay Differential Input to Output for “LS-Type” Load

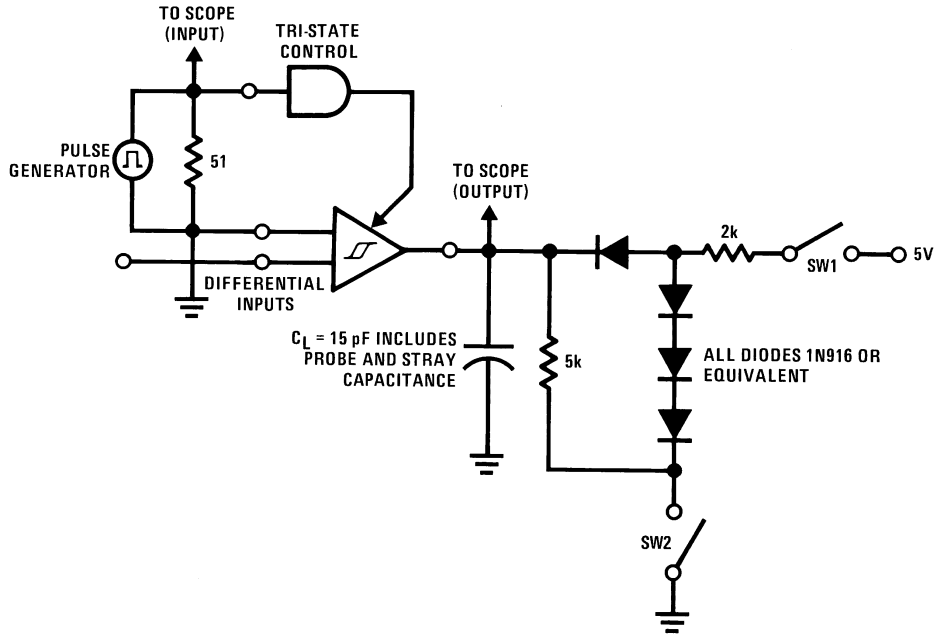

00869908

1.5V for t_{pHZ} and t_{pLZ}
 -1.5V for t_{pLZ} and t_{pZL}
 Input Pulse Characteristics:
 $t_{TLH} = t_{THL} = 6\text{ ns}$ (10% to 90%)
 PRR = 1 MHz, 50% duty cycle

AC Test Circuits and Switching Time Waveforms (Continued)

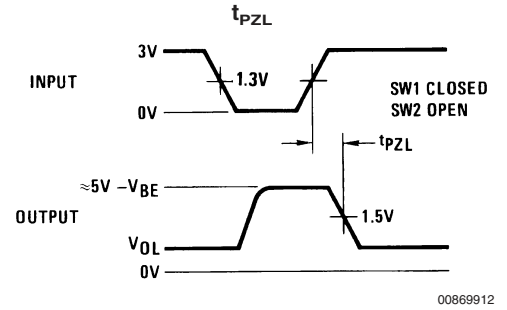
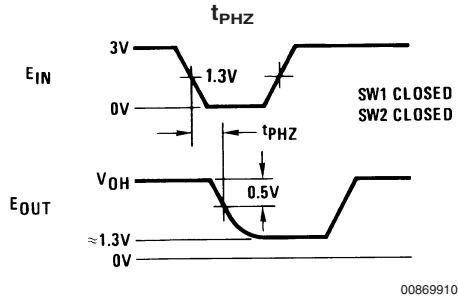
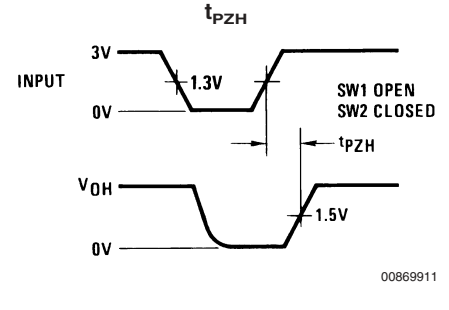
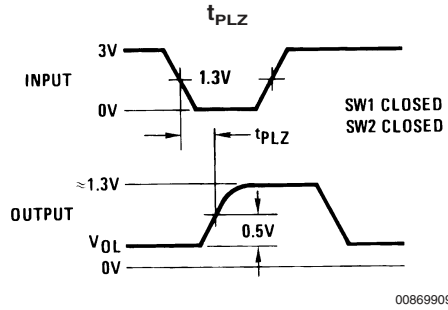
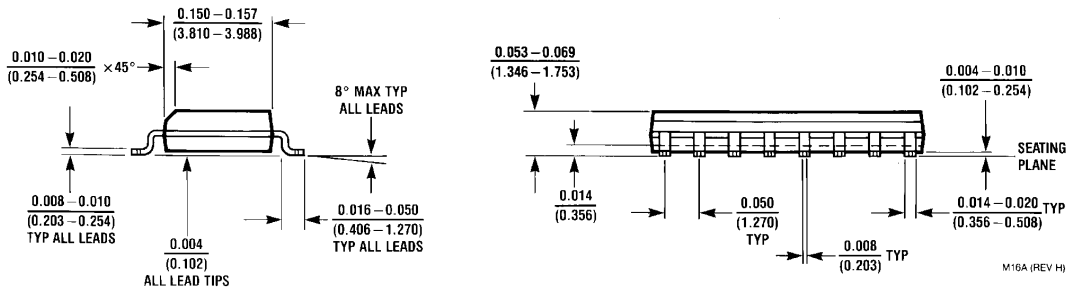
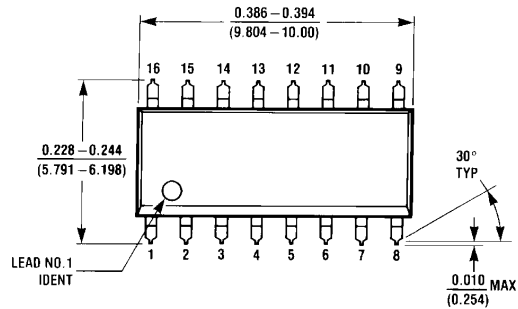
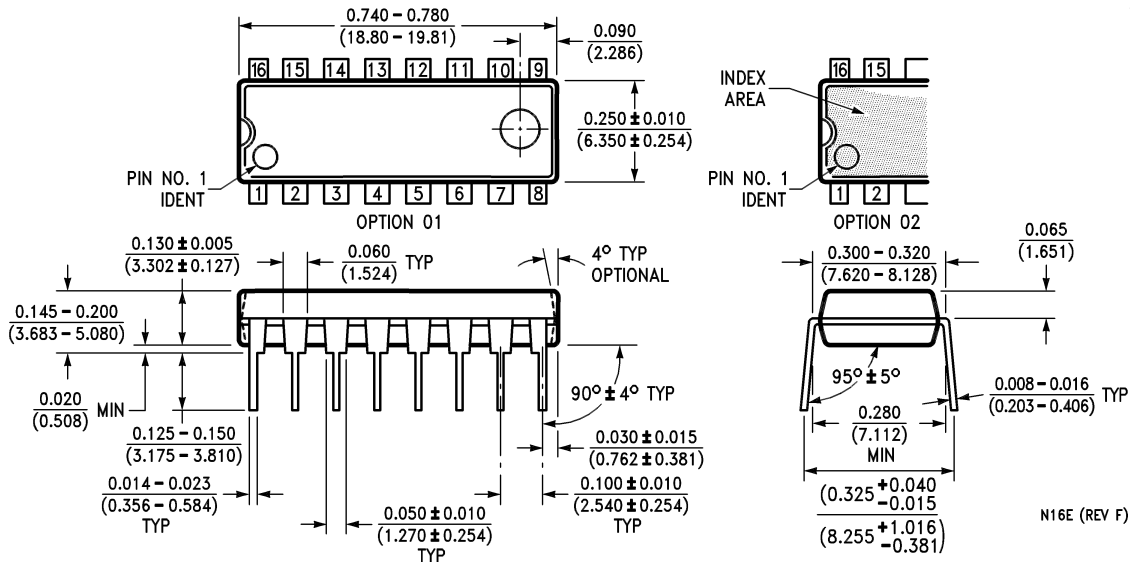

FIGURE 5. Propagation Delay TRI-STATE Control Unit to Output for "LS-Type" Load

Physical Dimensions inches (millimeters) unless otherwise noted



16-Lead Molded Small Outline Package (M)
Order Number DS34C86TM
NS Package Number M16A



16-Lead Dual-In-Line Package (N)
Order Number DS34C86TN
NS Package Number N16E

Notes

LIFE SUPPORT POLICY

NATIONAL'S PRODUCTS ARE NOT AUTHORIZED FOR USE AS CRITICAL COMPONENTS IN LIFE SUPPORT DEVICES OR SYSTEMS WITHOUT THE EXPRESS WRITTEN APPROVAL OF THE PRESIDENT AND GENERAL COUNSEL OF NATIONAL SEMICONDUCTOR CORPORATION. As used herein:

- | | |
|--|---|
| <p>1. Life support devices or systems are devices or systems which, (a) are intended for surgical implant into the body, or (b) support or sustain life, and whose failure to perform when properly used in accordance with instructions for use provided in the labeling, can be reasonably expected to result in a significant injury to the user.</p> | <p>2. A critical component is any component of a life support device or system whose failure to perform can be reasonably expected to cause the failure of the life support device or system, or to affect its safety or effectiveness.</p> |
|--|---|

BANNED SUBSTANCE COMPLIANCE

National Semiconductor certifies that the products and packing materials meet the provisions of the Customer Products Stewardship Specification (CSP-9-111C2) and the Banned Substances and Materials of Interest Specification (CSP-9-111S2) and contain no "Banned Substances" as defined in CSP-9-111S2.

 <p>National Semiconductor Americas Customer Support Center Email: new.feedback@nsc.com Tel: 1-800-272-9959 www.national.com</p>	<p>National Semiconductor Europe Customer Support Center Fax: +49 (0) 180-530 85 86 Email: europe.support@nsc.com Deutsch Tel: +49 (0) 69 9508 6208 English Tel: +44 (0) 870 24 0 2171 Français Tel: +33 (0) 1 41 91 8790</p>	<p>National Semiconductor Asia Pacific Customer Support Center Email: ap.support@nsc.com</p>	<p>National Semiconductor Japan Customer Support Center Fax: 81-3-5639-7507 Email: jpn.feedback@nsc.com Tel: 81-3-5639-7560</p>
---	--	---	--

IMPORTANT NOTICE

Texas Instruments Incorporated and its subsidiaries (TI) reserve the right to make corrections, modifications, enhancements, improvements, and other changes to its products and services at any time and to discontinue any product or service without notice. Customers should obtain the latest relevant information before placing orders and should verify that such information is current and complete. All products are sold subject to TI's terms and conditions of sale supplied at the time of order acknowledgment.

TI warrants performance of its hardware products to the specifications applicable at the time of sale in accordance with TI's standard warranty. Testing and other quality control techniques are used to the extent TI deems necessary to support this warranty. Except where mandated by government requirements, testing of all parameters of each product is not necessarily performed.

TI assumes no liability for applications assistance or customer product design. Customers are responsible for their products and applications using TI components. To minimize the risks associated with customer products and applications, customers should provide adequate design and operating safeguards.

TI does not warrant or represent that any license, either express or implied, is granted under any TI patent right, copyright, mask work right, or other TI intellectual property right relating to any combination, machine, or process in which TI products or services are used. Information published by TI regarding third-party products or services does not constitute a license from TI to use such products or services or a warranty or endorsement thereof. Use of such information may require a license from a third party under the patents or other intellectual property of the third party, or a license from TI under the patents or other intellectual property of TI.

Reproduction of TI information in TI data books or data sheets is permissible only if reproduction is without alteration and is accompanied by all associated warranties, conditions, limitations, and notices. Reproduction of this information with alteration is an unfair and deceptive business practice. TI is not responsible or liable for such altered documentation. Information of third parties may be subject to additional restrictions.

Resale of TI products or services with statements different from or beyond the parameters stated by TI for that product or service voids all express and any implied warranties for the associated TI product or service and is an unfair and deceptive business practice. TI is not responsible or liable for any such statements.

TI products are not authorized for use in safety-critical applications (such as life support) where a failure of the TI product would reasonably be expected to cause severe personal injury or death, unless officers of the parties have executed an agreement specifically governing such use. Buyers represent that they have all necessary expertise in the safety and regulatory ramifications of their applications, and acknowledge and agree that they are solely responsible for all legal, regulatory and safety-related requirements concerning their products and any use of TI products in such safety-critical applications, notwithstanding any applications-related information or support that may be provided by TI. Further, Buyers must fully indemnify TI and its representatives against any damages arising out of the use of TI products in such safety-critical applications.

TI products are neither designed nor intended for use in military/aerospace applications or environments unless the TI products are specifically designated by TI as military-grade or "enhanced plastic." Only products designated by TI as military-grade meet military specifications. Buyers acknowledge and agree that any such use of TI products which TI has not designated as military-grade is solely at the Buyer's risk, and that they are solely responsible for compliance with all legal and regulatory requirements in connection with such use.

TI products are neither designed nor intended for use in automotive applications or environments unless the specific TI products are designated by TI as compliant with ISO/TS 16949 requirements. Buyers acknowledge and agree that, if they use any non-designated products in automotive applications, TI will not be responsible for any failure to meet such requirements.

Following are URLs where you can obtain information on other Texas Instruments products and application solutions:

Products

Audio	www.ti.com/audio
Amplifiers	amplifier.ti.com
Data Converters	dataconverter.ti.com
DLP® Products	www.dlp.com
DSP	dsp.ti.com
Clocks and Timers	www.ti.com/clocks
Interface	interface.ti.com
Logic	logic.ti.com
Power Mgmt	power.ti.com
Microcontrollers	microcontroller.ti.com
RFID	www.ti-rfid.com
OMAP Mobile Processors	www.ti.com/omap
Wireless Connectivity	www.ti.com/wirelessconnectivity

Applications

Communications and Telecom	www.ti.com/communications
Computers and Peripherals	www.ti.com/computers
Consumer Electronics	www.ti.com/consumer-apps
Energy and Lighting	www.ti.com/energy
Industrial	www.ti.com/industrial
Medical	www.ti.com/medical
Security	www.ti.com/security
Space, Avionics and Defense	www.ti.com/space-avionics-defense
Transportation and Automotive	www.ti.com/automotive
Video and Imaging	www.ti.com/video

TI E2E Community Home Page

e2e.ti.com

Mailing Address: Texas Instruments, Post Office Box 655303, Dallas, Texas 75265
Copyright © 2011, Texas Instruments Incorporated