

THIS DRAWING IS UNPUBLISHED. RELEASED FOR PUBLICATION
 © COPYRIGHT - By - ALL RIGHTS RESERVED.

LOC	DIST	REVISIONS					
		P	LTR	DESCRIPTION	DATE	DWN	APVD
G	14	N2		REVISED PER ECO-11-004820	11MAR11	RK	HMR

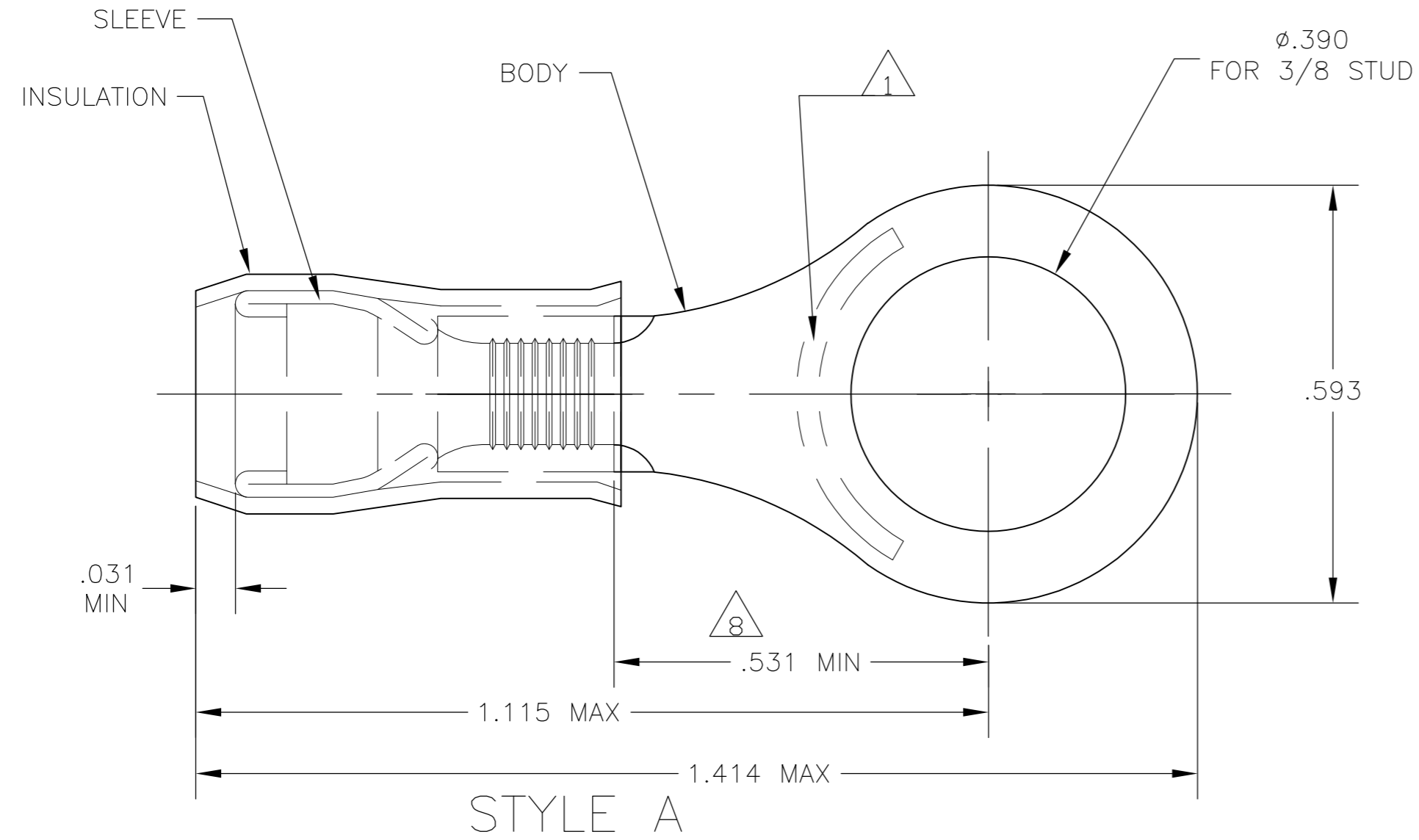

- 1 STAMP "AMP - SEE TABLE" APPROX AS SHOWN
- 2 WIRE INSULATION DIA: SEE TABLE
- 3 TONGUE MATERIAL THK: .040±.002
- 4 BODY: TIN PLATE .000100 MIN EXT THK PER ASTM B545
- 5 SLEEVE: TIN PLATE .000100 MIN EXT THK PER ASTM B545
- 6 SLEEVE: NICKEL PLATE PER QQ-N-290
- 7 BODY & SLEEVE- CU PER ASTM B152 INSULATION - NYLON PER ASTM D4066 COLOR - YELLOW
- 8 APPLIES FROM EDGE OF METAL WIRE BARREL TO CENTER OF STUD HOLE.
- 9 MEETS MS25036-114, CLASS 1 & 2
- 10 MEETS MS25036-114, CLASS 2
- 11 MEETS M7928/1-61, CLASS 1 & 2
- 12 MEETS M7928/1-68, CLASS 1 & 2

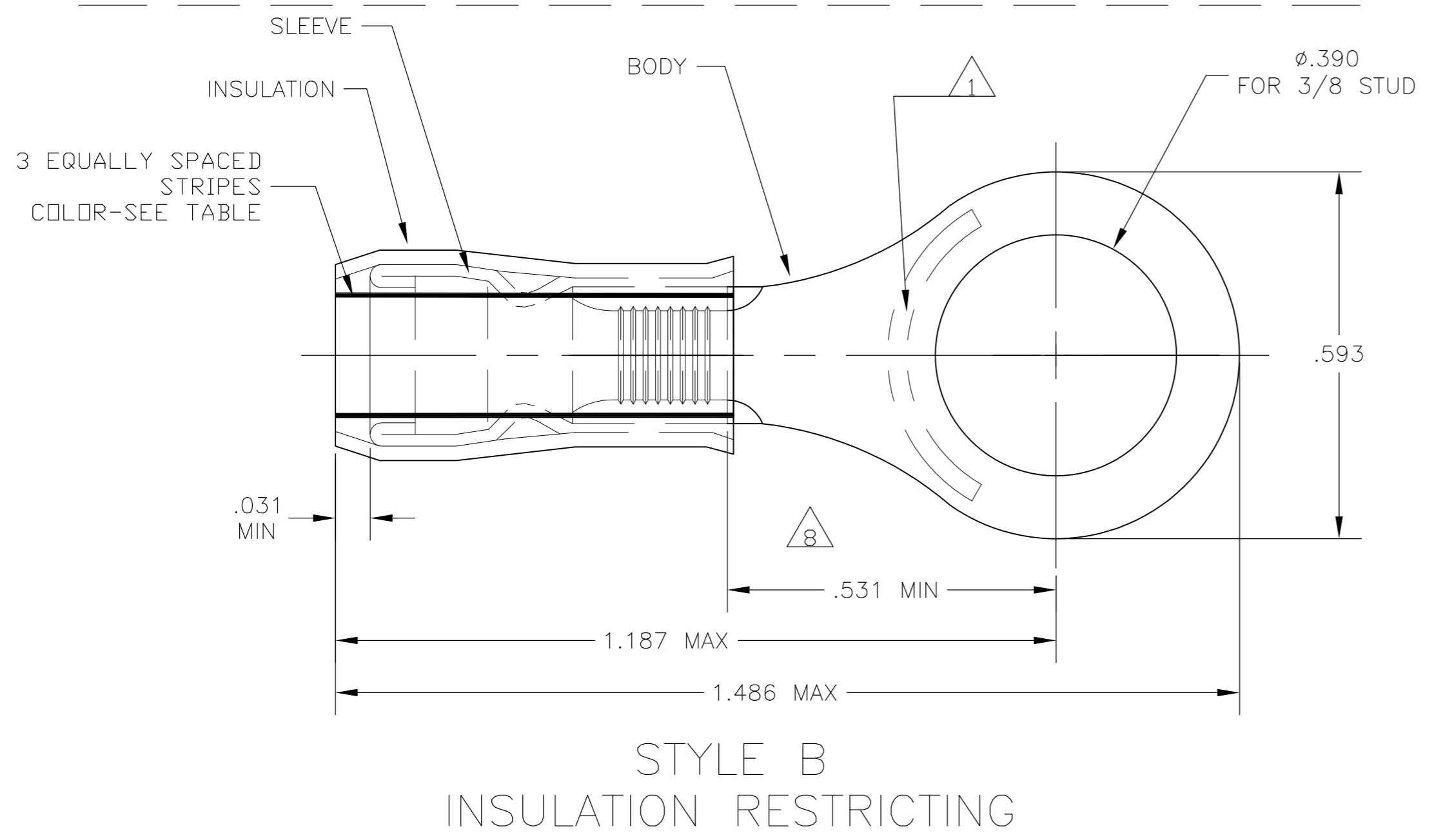

QTY	PACKAGE TYPE	STAMPING	WIRE INSUL DIA	WIRE SIZE	STRIPE COLOR	STYLE	BODY FINISH	SLEEVE FINISH	PART NO
200	LOOSE PIECE, BOX	10	.119-.200	10	BROWN	B		6	8-320577-5
50	LOOSE PIECE, BOX	12-10	.150-.230	12-10	---	A		5	8-320577-2
1000	ON TAPE & REEL	12-10	.150-.230	12-10	---	A	4	5	2-320577-3
500	LOOSE PIECE	10	.119-.200	10	BROWN	B		6	2-320577-2
500	LOOSE PIECE	12	.095-.200	12	YELLOW	B		6	2-320577-1
500	LOOSE PIECE	12-10	.150-.230	12-10	---	A		5	320577

CUSTOMER SERVICE SYSTEMS FOR ADDITIONAL PRODUCT INFORMATION OR COPIES OF DRAWINGS AND TECHNICAL DOCUMENTS: 1-800-522-6752 FOR APPLICATION TOOLING INFORMATION: 1-800-722-1111 FOR ORDER ENTRY: 1-800-526-5142		MAX RECOMMENDED OPERATING TEMPERATURE: 105°C MAX VOLTAGE RATING: 300 VOLT MAX CIRCULAR MIL AREA: 2.62-6.64mm² [5,180-13,100] STRANDED OR SOLID	THIS DRAWING IS A CONTROLLED DOCUMENT. DIMENSIONS: INCHES TOLERANCES UNLESS OTHERWISE SPECIFIED: 0 PLC ± - 1 PLC ± - 2 PLC ± - 3 PLC ± .008 4 PLC ± - ANGLES ± - MATERIAL: - FINISH: -	DWN: JR RUTH 23DEC09 CHK: T MICHIELUTTI 23DEC09 APVD: T MICHIELUTTI 23DEC09 PRODUCT SPEC: - APPLICATION SPEC: - WEIGHT: -	TE Connectivity NAME: TERMINAL, RING TONGUE, PIDG WIRE SIZE: 12-10 AWG SIZE: A2 CAGE CODE: 00779 DRAWING NO: C-320577 SCALE: 5:1 SHEET: 1 of 1 REV: N2
---	--	--	--	--	---