

- NOTE:
- MATERIAL:  
HOUSING: 30% GLASS FILLED PBT, THERMOPLASTIC, BLACK.  
CONTACT: PHOS BRONZE
  - FINISH: CONTACT PLATING: TIN-LEAD (60μ INCHES MIN.)  
SOLDERABILITY :95% COVERAGE MIN.;  
TEST TEMPERATURE=230°C±5°C  
TEST TIME = 5±5 SECONDS.
  - MECHANICAL SPECS:  
DURABILITY: 50 CYCLES MIN.  
INSERTION FORCE:300 GRAMS MAX.  
WITHDRAWAL FORCE: 20 GRAMS MIN.  
CONTACT RETENTION: 500 GRAMS MIN.  
ACCEPTS: 0.20-0.30 [.008-.012] LEADS
  - ELECTRICAL SPECS:  
VOLTAGE RATING: 250V AC,DC  
CONTACT RESISTANCE: 20 MILLOHMS MAX.  
CURRENT RATING: 1 AMPERE AC,DC  
INSULATION RESISTANCE: 1000 MEGOHMS MIN.  
DIELECTRIC WITHSTANDING VOLTAGE: AC 1000 V MIN.
  - OPERATING TEMPERATURE: -40°C TO +105°C
  - AMP LOGO
  - FINISH: CONTACT PLATING TIN (LEAD FREE); 60 UIN MIN. OVER 30 UIN Ni  
SOLDERABILITY :95% COVERAGE MIN.;  
TEST TEMPERATURE=260'±5°C;  
TEST TIME = 5±5 SECONDS.

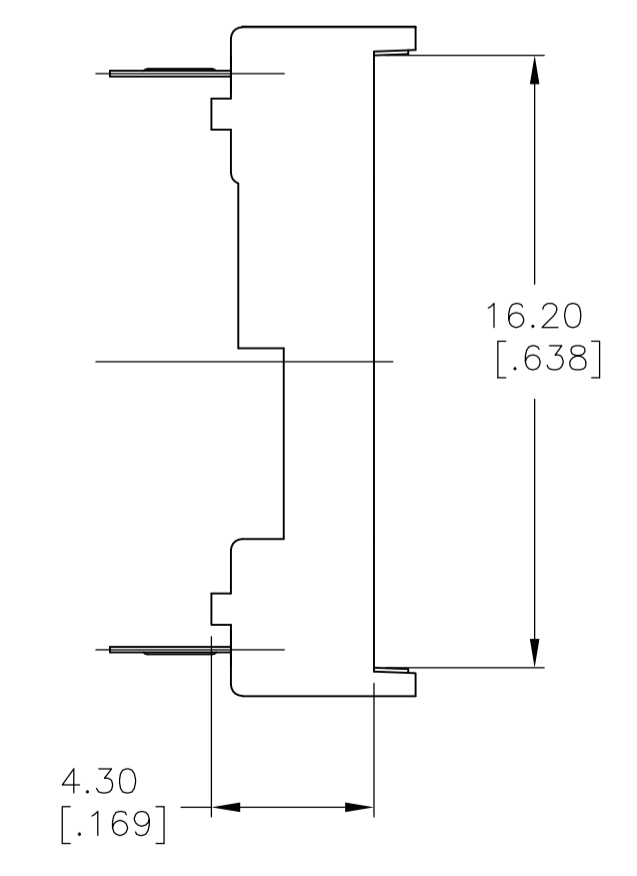
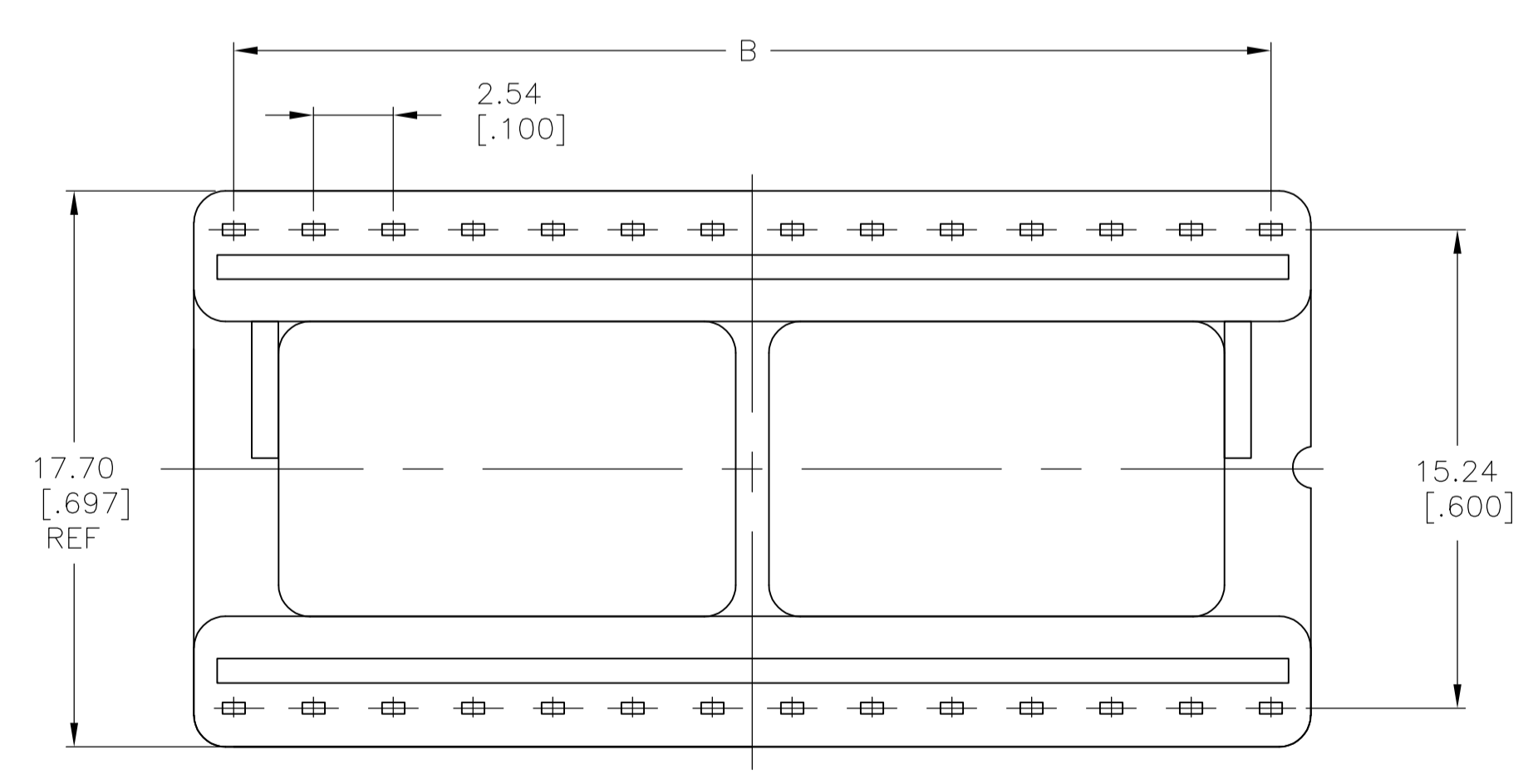
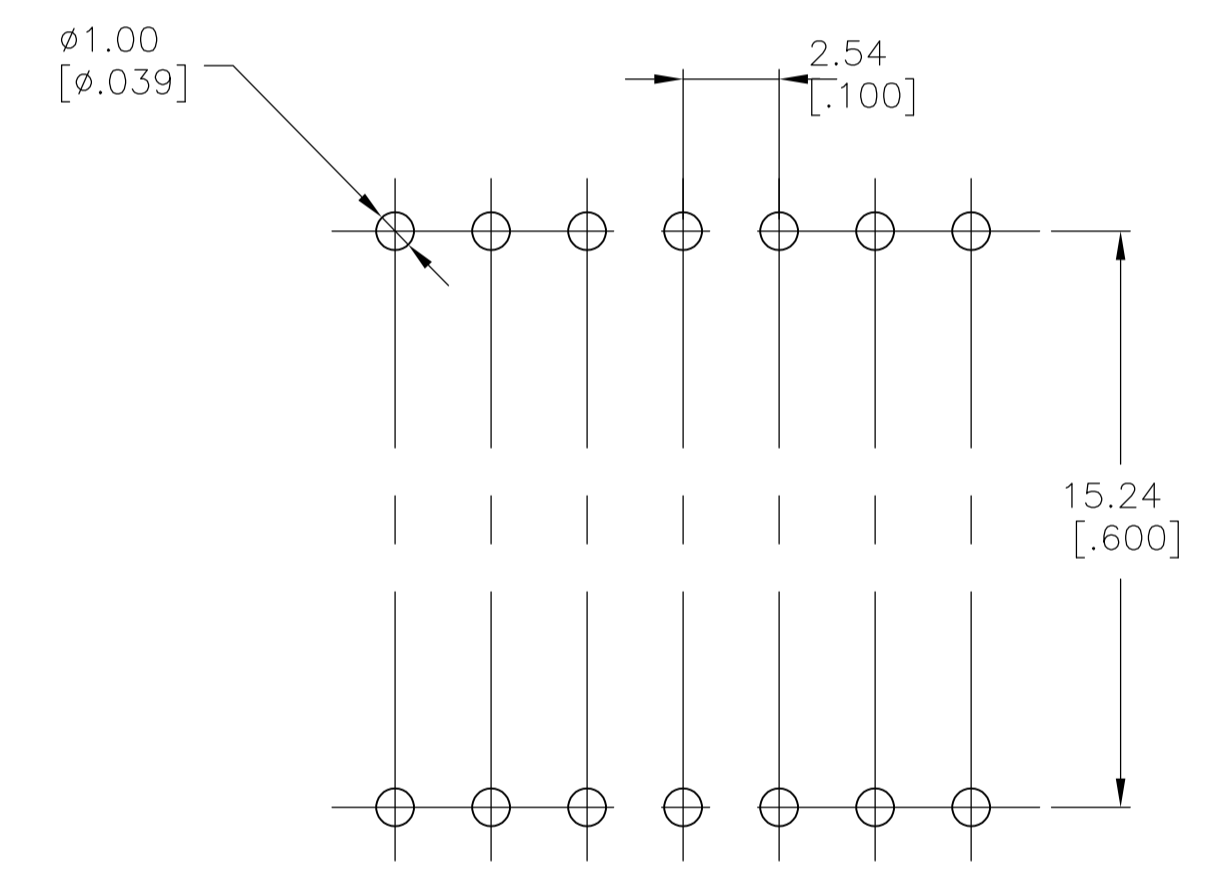
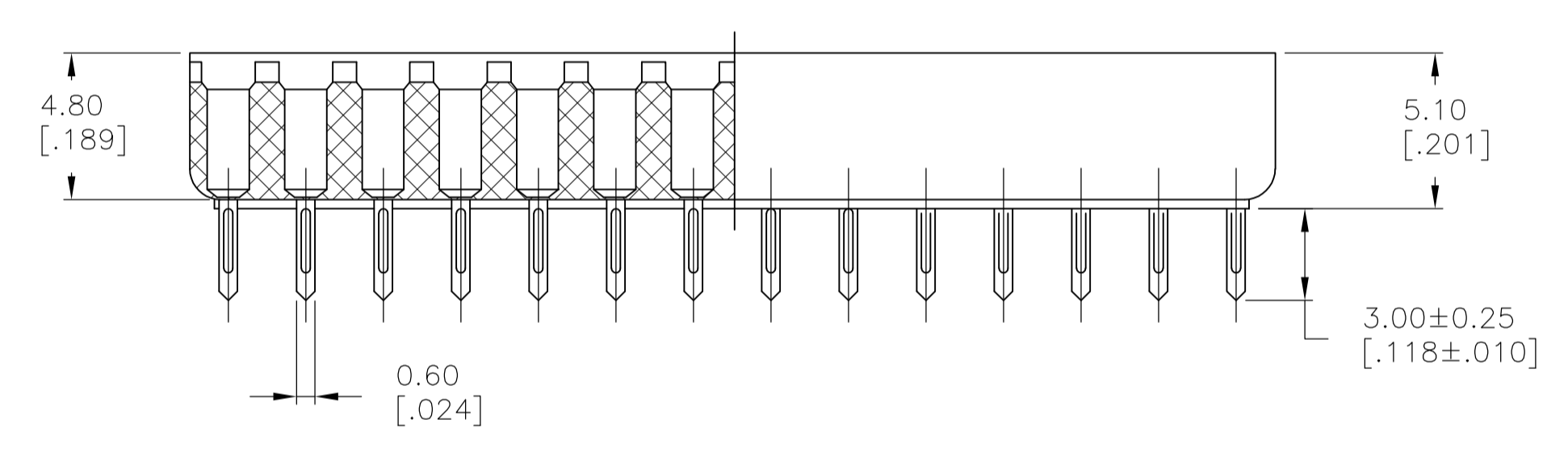

SUPERSEDED BY 1-390262-7  
 SUPERSEDED BY 1-390262-6  
 SUPERSEDED BY 1-390262-5  
 SUPERSEDED BY 1-390262-3  
 SUPERSEDED BY 1-390262-2  
 SUPERSEDED BY 1-390262-1

△7	48	60.96 [2.400]	58.42 [2.300]	1-390262-7
△7	42	53.34 [2.100]	50.8 [2.000]	1-390262-6
△7	40	50.80 [2.000]	48.26 [1.900]	1-390262-5
△7	32	40.64 [1.600]	38.10 [1.500]	1-390262-3
△7	28	35.56 [1.400]	33.02 [1.300]	1-390262-2
△7	24	30.48 [1.200]	27.94 [1.100]	1-390262-1
△2	48	60.96 [2.400]	58.42 [2.300]	390262-7
△2	42	53.34 [2.100]	50.8 [2.000]	390262-6
△2	40	50.80 [2.000]	48.26 [1.900]	390262-5
△2	32	40.64 [1.600]	38.10 [1.500]	390262-3
△2	28	35.56 [1.400]	33.02 [1.300]	390262-2
△2	24	30.48 [1.200]	27.94 [1.100]	390262-1
FINISH	POS	A±0.20 [.008]	B±0.15 [.006]	PART NO.

THIS DRAWING IS A CONTROLLED DOCUMENT. DSN BSV 07SEP04  
 DIMENSIONS: mm [INCHES] TOLERANCES UNLESS OTHERWISE SPECIFIED:  
 0 PLG ±  
 1 PLG ±  
 2 PLG ± 0.2[.008]  
 3 PLG ±  
 4 PLG ±  
 ANGLES ±

MATERIAL △1 FINISH △2-△7

APVD: [Signature] DATE: 11MAR11  
 PRODUCT SPEC: [Blank]  
 APPLICATION SPEC: [Blank]  
 WEIGHT: [Blank]  
 CUSTOMER DRAWING

**OBSELETE** NOT the LATEST REVISION

SCALE: 5:1 SHEET: 1 OF 1 REV: M1