

THIS DRAWING IS UNPUBLISHED. RELEASED FOR PUBLICATION  
 © COPYRIGHT BY TYCO ELECTRONICS CORPORATION. ALL INTERNATIONAL RIGHTS RESERVED.

LOC	DIST	REVISIONS					
		P	LTR	DESCRIPTION	DATE	DWN	APVD
G	02		T1	REVISED PER ECR-08-021718	08SEP08	HMR	TM

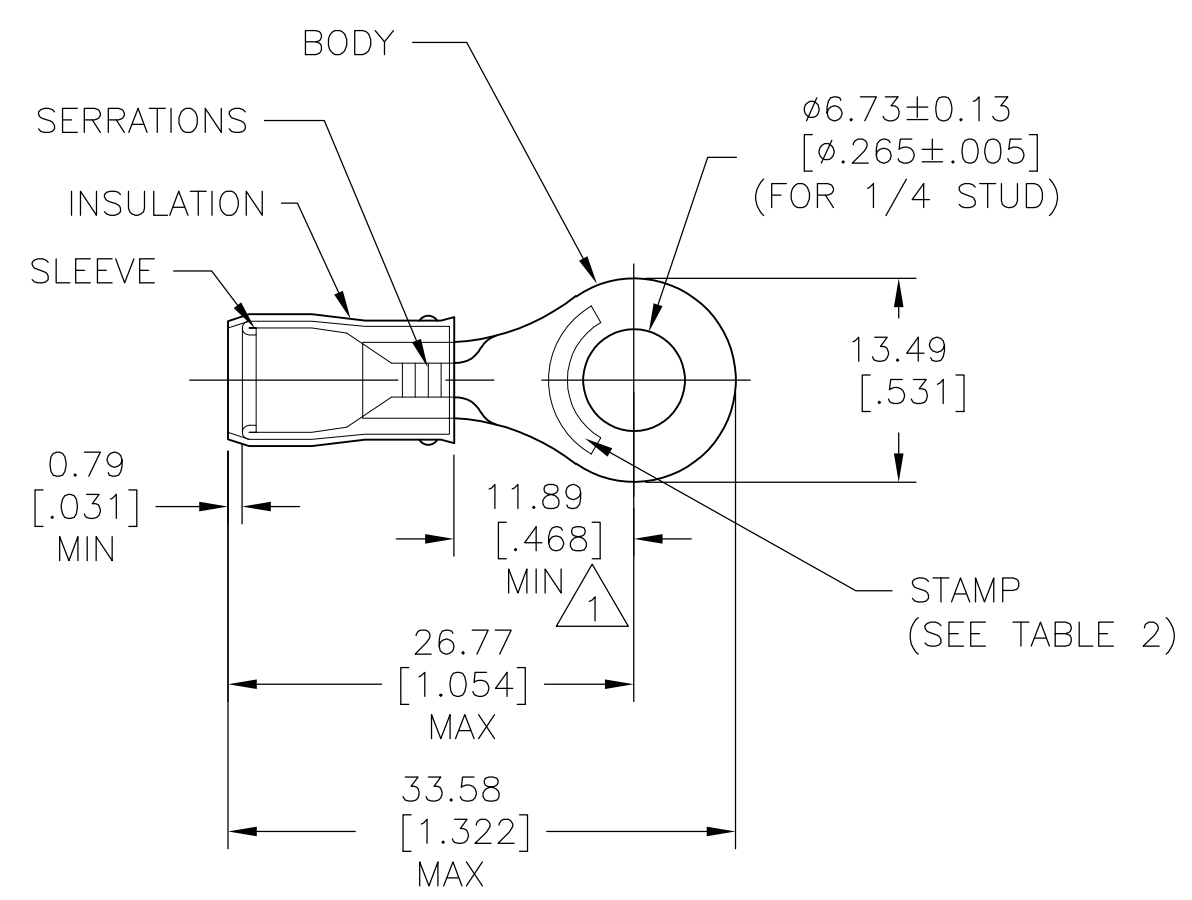

STYLE "A" - STANDARD

- 1 DIMENSION APPLIES FROM EDGE OF METAL WIRE BARREL TO CENTER OF STUD.
- 2 TONGUE MATERIAL THK 1.02 ± .05 [.040 ± .002]
- 3 105°C MAX OPERATING TEMPERATURE
- 4 300 VOLT MAX.
- 5 CIRCULAR MIN AREA: 2.62-6.64 mm<sup>2</sup> [5180-13100] SOLID OR STRANDED
- 6 UL LISTED E13288 12-10 AWG SOLID OR STRANDED
- 7 CSA CERTIFIED LR7189 12-10 AWG SOLID OR STRANDED
- 8 MILITARY MS25036-157 CLASS 1
- 9 MILITARY MS25036-157 CLASS 2

QTY	MATERIAL & FINISH	PACKAGING	PART NO.
50	BODY & SLEEVE: COPPER PER ASTM B-152 TIN PLATE PER ASTM B-545	LOOSE PC, BOX	8-320569-2
500	INSULATION: NYLON PER ASTM D-4066, TYPE 1, COLOR: YELLOW	LOOSE PIECE	320569

PART NO.	COLOR STRIPE	WIRE SIZE	FOR WIRE INSULATION OD	STAMP	STYLE	PART NO. ON TAPE
8-320569-2	NONE	12-10	3.81-5.84 [.150-.230]	AMP 12-10*	"A"	-
8 320569 9	NONE	12-10	3.81-5.84 [.150-.230]	AMP 12-10*	"A"	2-320569-3 9

THIS DRAWING IS A CONTROLLED DOCUMENT.	
DIMENSIONS: mm [INCHES]	TOLERANCES UNLESS OTHERWISE SPECIFIED:
	0 PLC ± -
	1 PLC ± 0.2 [.008]
	2 PLC ± -
	3 PLC ± -
	4 PLC ± -
MATERIAL SEE TABLE 1	ANGLES ± 0°30'
	FINISH -

DWN RAGHAVENDRA 08SEP2008	Tyco Electronics Corporation Harrisburg, PA 17105-3608	
CHK T MICHIELUTTI 08SEP2008	NAME	
APVD T MICHIELUTTI 08SEP2008	NAME	
PRODUCT SPEC -	TERMINAL RING TONGUE, NYLON, PIDG, WIRE SIZE: 12-10	
APPLICATION SPEC -	SIZE A3	CAGE CODE 00779
WEIGHT -	DRAWING NO G-320569	RESTRICTED TO -
CUSTOMER DRAWING		SCALE 2:1
		SHEET 1 OF 2
		REV T1

THIS DRAWING IS UNPUBLISHED. RELEASED FOR PUBLICATION  
 © COPYRIGHT BY TYCO ELECTRONICS CORPORATION. ALL INTERNATIONAL RIGHTS RESERVED.

LOC	DIST	REVISIONS					
		P	LTR	DESCRIPTION	DATE	DWN	APVD
G	02	-	-	SEE SHEET 1	-	-	-

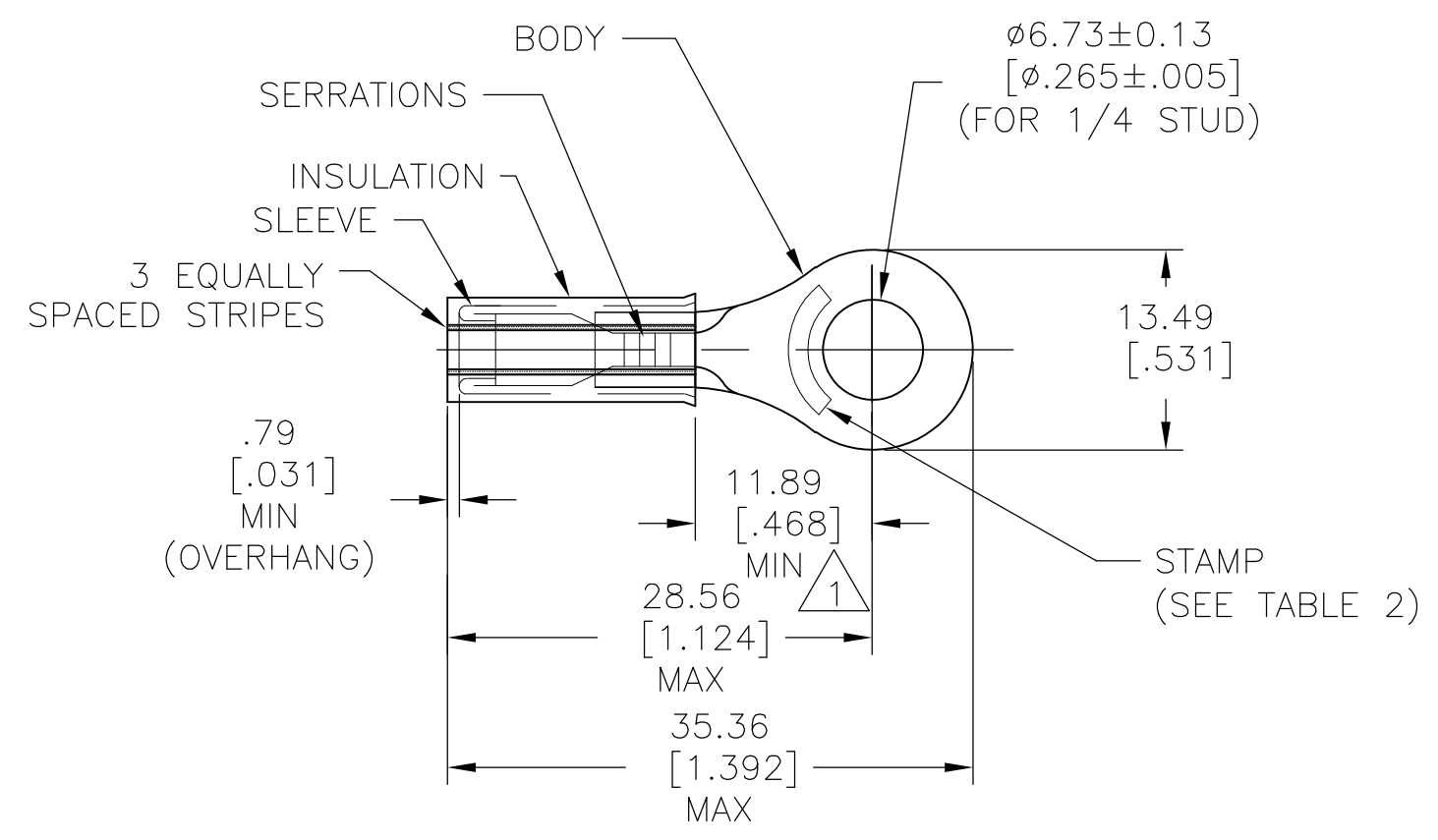

STYLE "B" - INSULATION RESTRICTING

- 1 DIMENSION APPLIES FROM EDGE OF METAL WIRE BARREL TO CENTER OF STUD.
- 2 TONGUE MATERIAL THK 1.02 ± 0.05 [.040 ± .002]
- 3 105°C MAX OPERATING TEMPERATURE
- 4 300 VOLT MAX.
- 5 CIRCULAR MIN AREA: 2.62-6.64 mm<sup>2</sup> [5180-13100] SOLID OR STRANDED
- 6 MILITARY M7928/1-59 CLASS 1
- 7 MILITARY M7928/1-66 CLASS 1
- 8 MILITARY M7928/1-59 CLASS 2
- 9 MILITARY M7928/1-66 CLASS 2

TABLE 1			
QTY	MATERIAL & FINISH	PACKAGING	PART NO.
500	BODY: COPPER PER ASTM B-152 TIN PLATE PER ASTM B-545	LOOSE PIECE	2-320569-6
	SLEEVE: COPPER PER ASTM B-152 NICKEL PLATE PER QQ-N-290		2-320569-5
	INSULATION: NYLON PER ASTM D-4066, TYPE 1 COLOR: YELLOW		

TABLE 2						
PART NO.	COLOR STRIPE	WIRE SIZE	FOR WIRE INSULATION OD	STAMP	STYLE	PART NO. ON TAPE
2-320569-6	BROWN	10	3.02-5.08 [.119-.200]	AMP 10*	"B"	2-320569-8
2-320569-5	YELLOW	12	2.41-5.08 [.095-.200]	AMP 12*	"B"	2-320569-7
						OBSOLETE

THIS DRAWING IS A CONTROLLED DOCUMENT.

DIMENSIONS: mm [INCHES]	TOLERANCES UNLESS OTHERWISE SPECIFIED:
	0 PLC ± -
	1 PLC ± 0.2 [.008]
	2 PLC ± -
	3 PLC ± -
	4 PLC ± -
	ANGLES ± 0°30'
MATERIAL SEE TABLE 1	FINISH -

DWN RAGHAVENDRA 08SEP2008	Tyco Electronics Corporation Harrisburg, PA 17105-3608	
CHK T MICHELUTTI 08SEP2008	NAME T MICHELUTTI	
APVD T MICHELUTTI 08SEP2008	PRODUCT SPEC -	
APPLICATION SPEC -	WEIGHT -	
CUSTOMER DRAWING	SCALE 2:1	SHEET 2 OF 2
SIZE A3	CAGE CODE 00779	DRAWING NO G-320569
RESTRICTED TO -	REV T1	