

THIS DRAWING IS UNPUBLISHED. RELEASED FOR PUBLICATION
 © COPYRIGHT - By - ALL RIGHTS RESERVED.

LOC		DIST		REVISIONS			
P	LTR	DESCRIPTION		DATE	DWN	APVD	
M1		REVISED PER ECO-11-004587		11MAR11	RK	HMR	

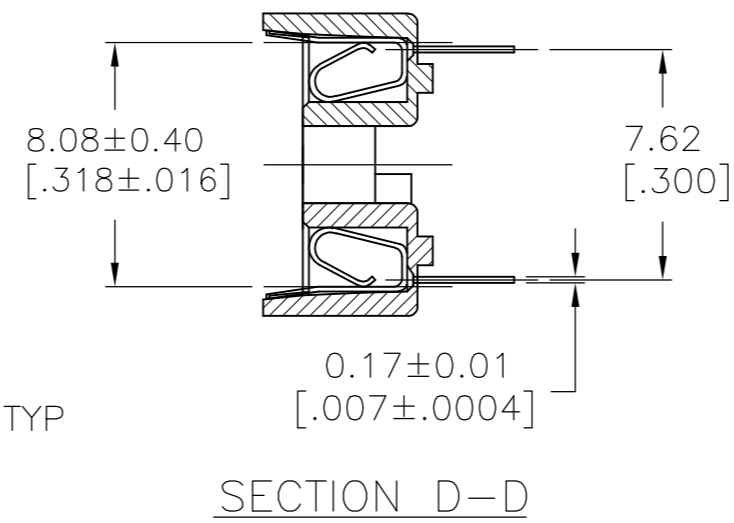
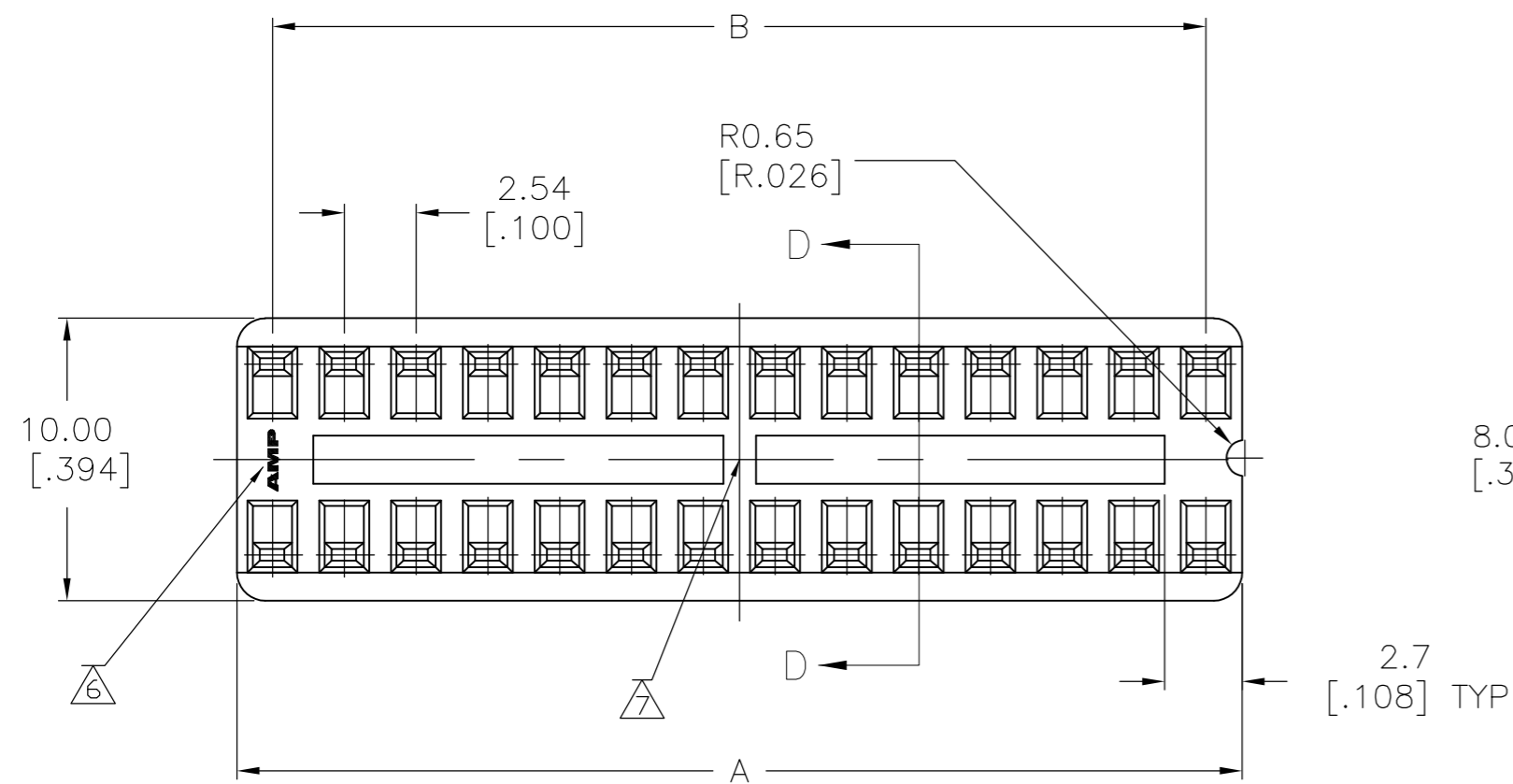

NOTE:

- 1 MATERIAL:
HOUSING: 30% GLASS FILLED PBT, THERMOPLASTIC, BLACK.
CONTACT: PHOS BRONZE
- 2 FINISH: CONTACT PLATING: TIN-LEAD (60u INCHES MIN.)
SOLDERABILITY :95% COVERAGE MIN.;
TEST TEMPERATURE=230°C±5°C
TEST TIME = 5±5 SECONDS.
- 3. MECHANICAL SPECS:
DURABILITY: 50 CYCLES MIN.
INSERTION FORCE:300 GRAMS MAX.
WITHDRAWAL FORCE: 20 GRAMS MIN.
CONTACT RETENTION: 500 GRAMS MIN.
ACCEPTS: 0.20-0.30 [.008-.012] LEADS
- 4. ELECTRICAL SPECS:
VOLTAGE RATING: 250V AC,DC
CONTACT RESISTANCE: 20 MILLOHMS MAX.
CURRENT RATING: 1 AMPERE AC,DC
INSULATION RESISTANCE: 1000 MEGOHMS MIN.
DIELECTRIC WITHSTANDING VOLTAGE: AC 1000 V MIN.
- 5. OPERATING TEMPERATURE: -40°C TO +105°C
- 6 AMP LOGO
- 7 LADDER PRESENT FOR 24, 28 & 32 POSITION SOCKETS.
- 8 FINISH: CONTACT PLATING TIN (LEAD FREE); 60 UIN MIN. OVER 30 UIN Ni
SOLDERABILITY :95% COVERAGE MIN.;
TEST TEMPERATURE=260°±5°C;
TEST TIME = 5±5 SECONDS.

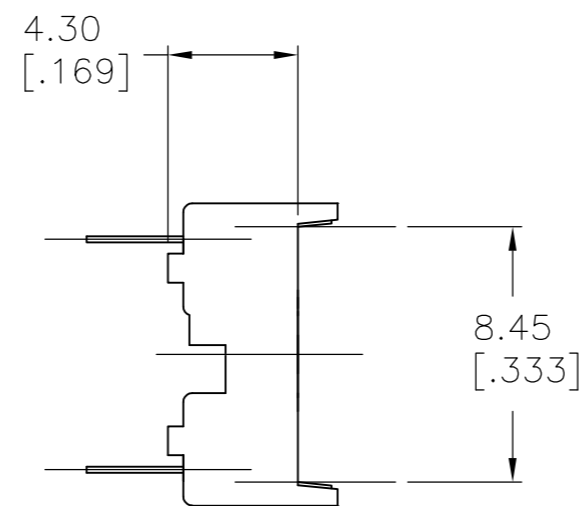
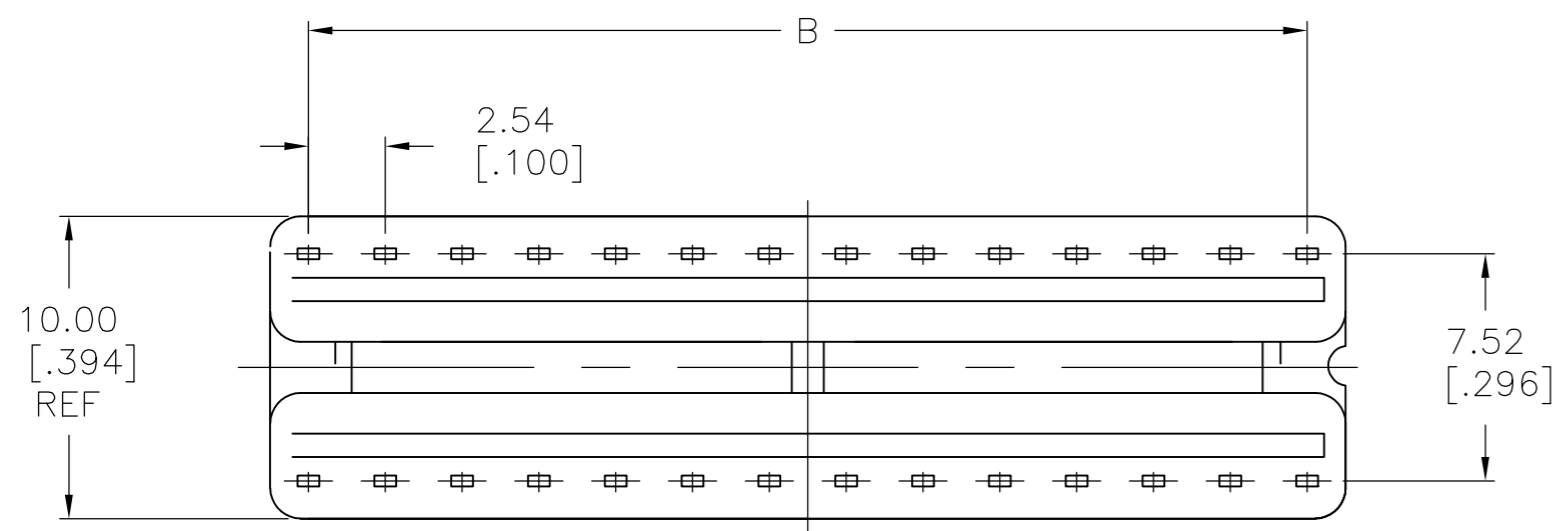
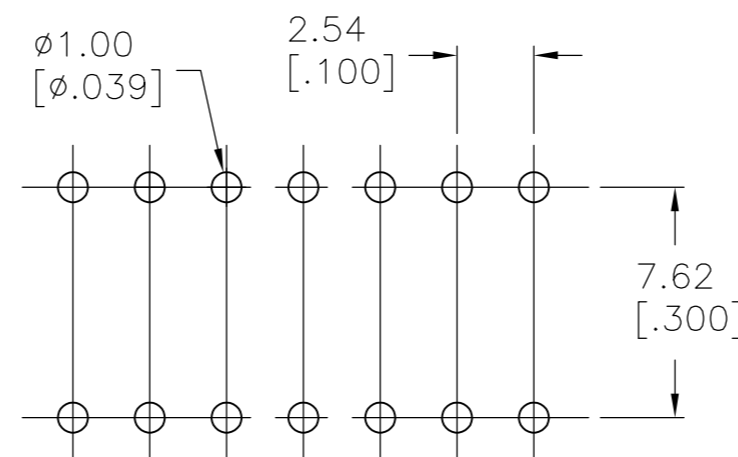
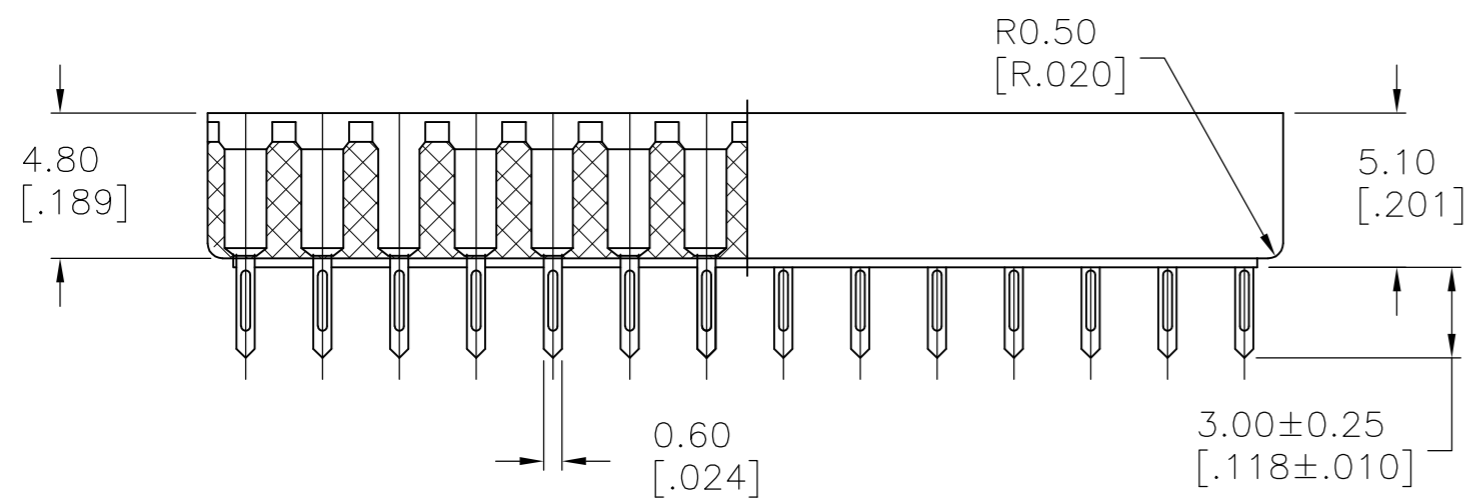

FINISH	POS	A ±0.20 [.008]	B±0.15 [.006]	PART NO.
8	32	40.64 [1.600]	38.10 [1.500]	2-390261-0
8	28	35.56 [1.400]	33.02 [1.300]	1-390261-9
8	24	30.48 [1.200]	27.94 [1.100]	1-390261-8
8	22	27.94 [1.100]	25.40 [1.000]	1-390261-7
8	20	25.40 [1.000]	22.86 [.900]	1-390261-6
8	18	22.86 [.900]	20.32 [.800]	1-390261-5
8	16	20.32 [.800]	17.78 [.700]	1-390261-4
8	14	17.78 [.700]	15.24 [.600]	1-390261-3
8	8	10.16 [.400]	7.62 [.300]	1-390261-2
8	6	7.62 [.300]	5.08 [.200]	1-390261-1
2	32	40.64 [1.600]	38.10 [1.500]	1-390261-0
2	28	35.56 [1.400]	33.02 [1.300]	390261-9
2	24	30.48 [1.200]	27.94 [1.100]	390261-8
2	22	27.94 [1.100]	25.40 [1.000]	390261-7
2	20	25.40 [1.000]	22.86 [.900]	390261-6
2	18	22.86 [.900]	20.32 [.800]	390261-5
2	16	20.32 [.800]	17.78 [.700]	390261-4
2	14	17.78 [.700]	15.24 [.600]	390261-3
2	8	10.16 [.400]	7.62 [.300]	390261-2
2	6	7.62 [.300]	5.08 [.200]	390261-1

SUPERSEDED BY 2-390261-0
 SUPERSEDED BY 1-390261-9
 SUPERSEDED BY 1-390261-8
 SUPERSEDED BY 1-390261-7
 SUPERSEDED BY 1-390261-6
 SUPERSEDED BY 1-390261-5
 SUPERSEDED BY 1-390261-4
 SUPERSEDED BY 1-390261-3
 SUPERSEDED BY 1-390261-2
 SUPERSEDED BY 1-390261-1

THIS DRAWING IS A CONTROLLED DOCUMENT. DWN BSV 06SEP2004
 CHK -
 APVD -
 PRODUCT SPEC -
 APPLICATION SPEC -
 MATERIAL -
 FINISH -

DIMENSIONS: mm [INCHES]
 TOLERANCES UNLESS OTHERWISE SPECIFIED:
 0 PLC ± -
 1 PLC ± -
 2 PLC ± 0.2 [.008]
 3 PLC ± -
 4 PLC ± -
 ANGLES ± -

TE Connectivity
OBsolete
 DIP SOCKET, .300 CENTER LINE
 LADDER STYLE
NOT the LATEST REVISION

SCALE: 4:1 SHEET: 1 OF 1 REV: M1