

LOC	DIST	REV	DESCRIPTION	DATE	DWN	APVD
G	14	P	LTR			
		R	REV PER ECR 09-026308	10DEC09	JR	TM

<b>AMP</b> WIRE RANGE	Listed FILE E13288	Certified LR7189
22-16 AWG SOLID OR STRANDED	22-16 AWG SOLID OR STRANDED	22-16 AWG SOLID OR STRANDED

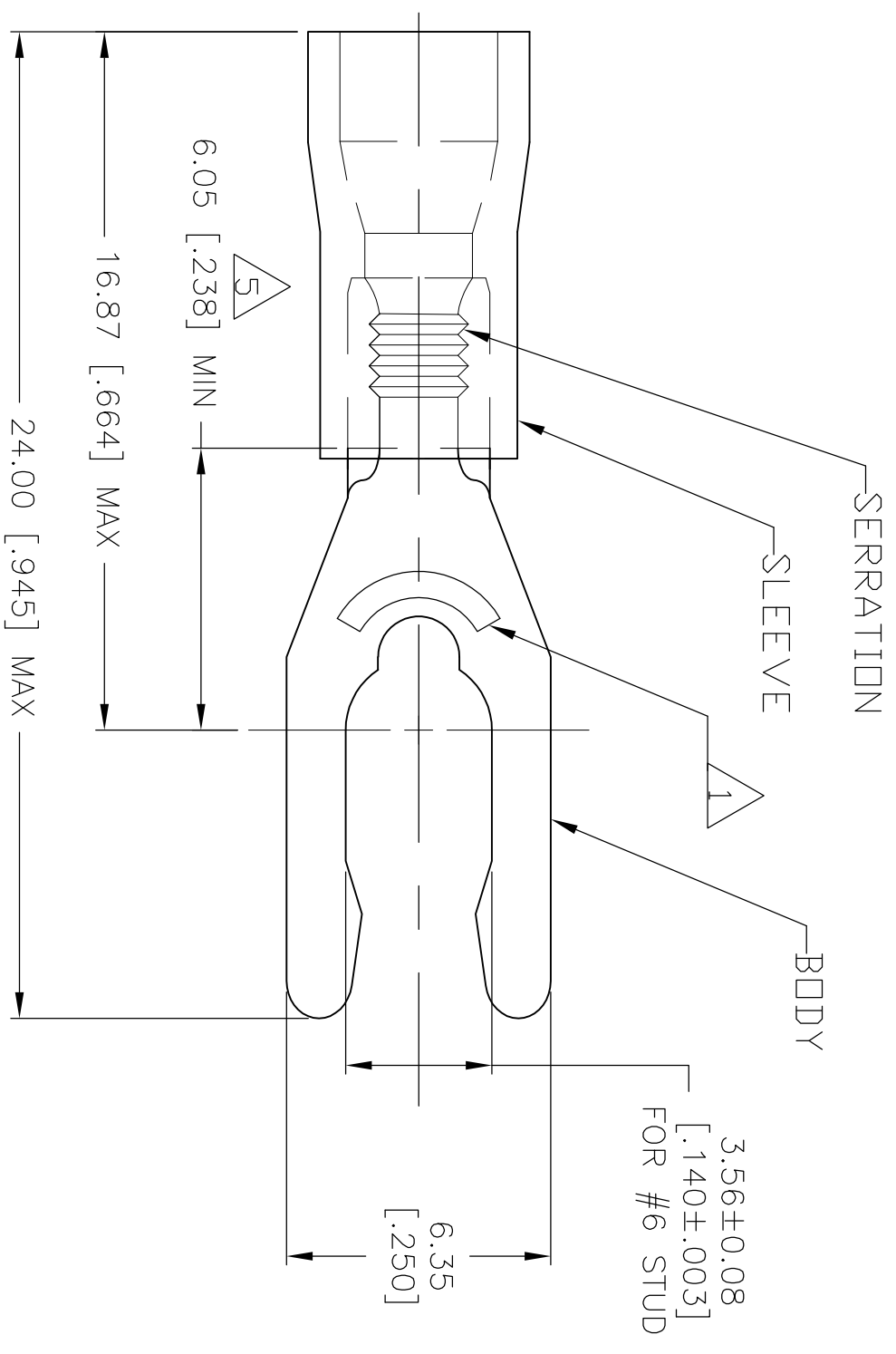

- 1 STAMP "AMP 22-18\*" APPROX AS SHOWN  
22-16 TERMINALS ARE STAMPED 22-18 IN  
ACCORDANCE WITH MILITARY SPEC MIL-T-7928  
COMMERCIAL WIRE RANGE IS 22-16
2. WIRE INSUL DIA, 2.67-3.56 [.105-.140]
3. TONGUE MATL THK, 0.79±0.05 [.031±.002]
- 4 MATERIAL: BODY - PHOS BRZ. PER ASTM B36  
SLEEVE - PVC, COLOR - RED
- 5 APPLIES FROM THE EDGE OF METAL BARREL TO  
THE CENTER OF THE STUD.

QTY	PACKAGE TYPE	PART NO
100	LOOSE PIECE, BOX	8-52453-1
5000	ON TAPE, REEL	52453-1
1000	LOOSE PIECE	52453

CUSTOMER SERVICE SYSTEMS  
 MAX RECOMMENDED OPERATING TEMPERATURE: 105°C [221°F]

FOR ADDITIONAL COPIES OF DRAWINGS AND TECHNICAL DOCUMENTS	PRODUCT INFORMATION CENTER 1-800-522-6752	VOLTAGE RATING: 600V MAX (1000V FIXTURE OR SIGN)
FOR APPLICATION	TOOLING ASSISTANCE CENTER 1-800-722-1111	CIRCULAR MIL AREA: 0.26-1.65mm <sup>2</sup> [509-3260] SOLID OR STRANDED
TOOLING INFORMATION		
FOR ORDER ENTRY	1-800-526-5142	

THIS DRAWING IS A CONTROLLED DOCUMENT.

DIMENSIONS: mm [INCHES]	TOLERANCES UNLESS OTHERWISE SPECIFIED:
0 PLC 1 PLC 2 PLC 3 PLC 4 PLC ANGLES	± - ± - ± 0.20 [.008] ± - ± - ± -
MATERIAL	TIN PER ASTM B545

DMN L OLMEDA CHK M ELLIS APVD G NGO	26JUN95 26JUN95 26JUN95		Tyco Electronics Corporation Harrisburg, Pa 17105-3608
PRODUCT SPEC APPLICATION SPEC WEIGHT	UL 486A —	NAME SIZE CAGE CODE DRAWING NO	TERMINAL, SPRING SPADE, LONG, PLASTI-GRIP, WIRE SIZE: 22-16 AWG A3 00779 52453
CUSTOMER DRAWING	SCALE 6:1	SHEET 1 OF 1	RESTRICTED TO REV R