

DET.	QTY.	DESCRIPTION	MATERIAL	FINISH
1	1	MOLDED SHELL	ABS-FR	COLORS
2	2	BANANA PLUG S/A	---	NICKEL
3	2	SLOTTED SET SCREW	STEEL	ZINC

SYM	DESCRIPTION	REVISIONS	DATE	APPR

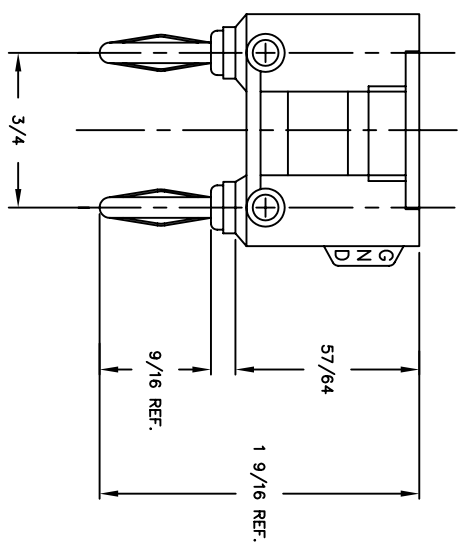
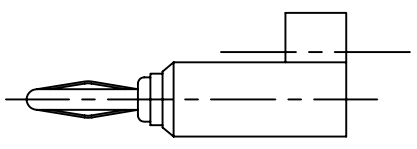
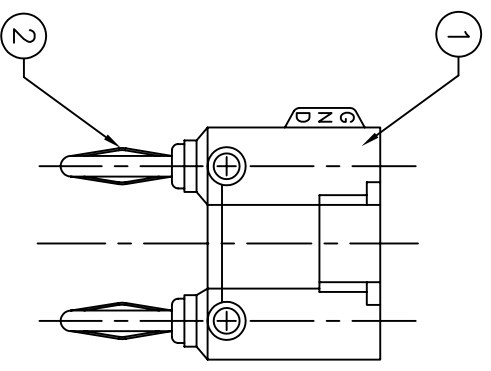
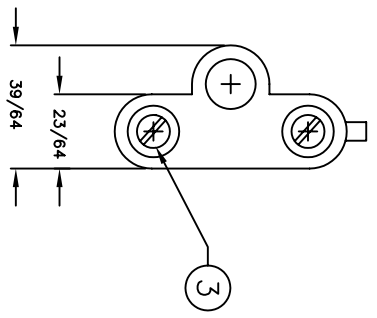

BANANA PLUG ASSEMBLY			
PART NO.	COLOR	CID#	
1675-101	WHITE		
1675-102	RED	AA55469/3-02	
1675-103	BLACK	AA55469/3-01	
1675-104	GREEN		
1675-105	BLUE		
1675-106	ORANGE		
1675-107	YELLOW		
1675-112	PURPLE		

MATERIAL:	"SEE TABLE"	FINISH:	"SEE TABLE"
DIMENSIONAL TOLERANCES UNLESS OTHERWISE SPECIFIED	.XX	ANGLES	SCALE
FRACTIONS	XX	SCALE	2:1
HEAT TREAT:	---	DATE:	07-12-91
PLOT SCALE:	1=1	DATE:	08-26-91
DRAWN: B.FRANKLIN		DATE:	07-26-91
CHECKED: E.MCKINNEY		DATE:	07-26-91
APPROVED: D.MILLER		DATE:	07-26-91
TITLE: 1675-1XX SERIES		SIZE:	SD-1675
DUAL BANANA PLUG ASSEMBLY		ISSUE:	C
Electronic Connectors and Hardware			
632 Arch Street, Meadville, Pa. 16335			

ABBATRON