

DC centrifugal fan

Series RLF 100 127 x 127 x 25



- **General description:** DC centrifugal fan with electronically commutated external rotor motor. Commutation electronics completely integrated. Very flat and high-performance centrifugal fan. Optional Vario-Pro: Highly adaptable software configuration of the fan enables a tailor-made solution to the specific requirements of your applications.

- **Impeller material:** Fiberglass-reinforced plastic

- **Housing material:** Fiberglass-reinforced plastic

Nominal data		Voltage	Voltage range VDC	Air flow	Speed	Power consumption	Sound level	Ambient temperature	L10 service life at 40 °C	L10 service life at max. temp.	Weight
Type	Motor	VDC	VDC	m³/h	1/min	W	Bel	°C	h	h	kg
RLF 100-11/14	--	24	16 - 30	64	5100	8.0	6.4	-20 .. 75	80000	30000	0.320
Subject to modification											

Characteristic: Pressure over air flow

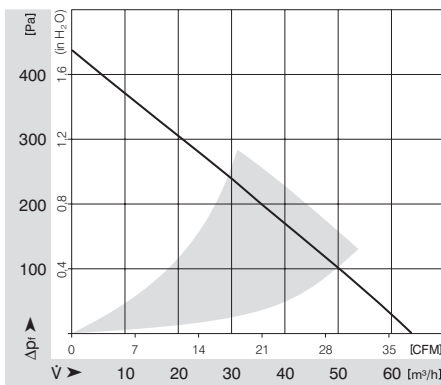

DC centrifugal fan

Series RLF 100 127 x 127 x 25

Specific drawing

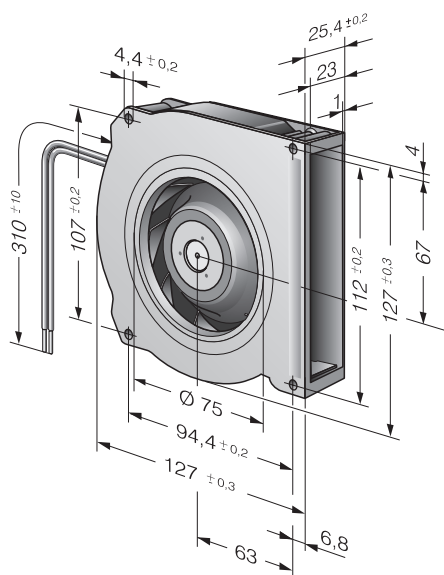

Technical description

- **General description:** DC centrifugal fan with electronically commutated external rotor motor. Commutation electronics completely integrated. Very flat and high-performance centrifugal fan. Optional Vario-Pro: Highly adaptable software configuration of the fan enables a tailor-made solution to the specific requirements of your applications.

- **Housing material:** Fiberglass-reinforced plastic

- **Direction of rotation:** Right, looking at rotor

- **Electrical connection:** 2 single strands AWG 22, TR 64

- **Locked-rotor protection:** Electronic locked-rotor and overload protection.

- **Option:** Alarm signal

- **Impeller material:** Fiberglass-reinforced plastic

- **Bearings:** Ball bearings

- **Direction of air flow:** Centrifugal

- **Motor protection:** With electronic reverse polarity protection. The fan runs only if the polarity is correct.

- **Approvals:** VDE, CSA, UL, CE

Contact

ebm-papst St. Georgen GmbH & Co. KG

Hermann-Papst-Straße 1

D-78112 St. Georgen

Phone +49 (0) 7724 / 81-0

Fax +49 (0) 7724 / 81-1309

info2@de.ebmpapst.com

www.ebmpapst.com