

# SG3525A

## Pulse Width Modulator Control Circuit

The SG3525A pulse width modulator control circuit offers improved performance and lower external parts count when implemented for controlling all types of switching power supplies. The on-chip +5.1 V reference is trimmed to  $\pm 1\%$  and the error amplifier has an input common-mode voltage range that includes the reference voltage, thus eliminating the need for external divider resistors. A sync input to the oscillator enables multiple units to be slaved or a single unit to be synchronized to an external system clock. A wide range of deadtime can be programmed by a single resistor connected between the  $C_T$  and Discharge pins. This device also features built-in soft-start circuitry, requiring only an external timing capacitor. A shutdown pin controls both the soft-start circuitry and the output stages, providing instantaneous turn off through the PWM latch with pulsed shutdown, as well as soft-start recycle with longer shutdown commands. The under voltage lockout inhibits the outputs and the changing of the soft-start capacitor when  $V_{CC}$  is below nominal. The output stages are totem-pole design capable of sinking and sourcing in excess of 200 mA. The output stage of the SG3525A features NOR logic resulting in a low output for an off-state.

### Features

- 8.0 V to 35 V Operation
- 5.1 V  $\pm$  1.0% Trimmed Reference
- 100 Hz to 400 kHz Oscillator Range
- Separate Oscillator Sync Pin
- Adjustable Deadtime Control
- Input Undervoltage Lockout
- Latching PWM to Prevent Multiple Pulses
- Pulse-by-Pulse Shutdown
- Dual Source/Sink Outputs:  $\pm$  400 mA Peak
- Pb-Free Packages are Available\*



ON Semiconductor®

### MARKING DIAGRAMS

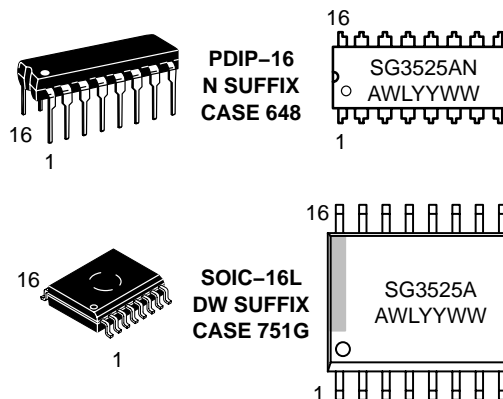

A = Assembly Location  
WL = Wafer Lot  
YY = Year  
WW = Work Week

### PIN CONNECTIONS

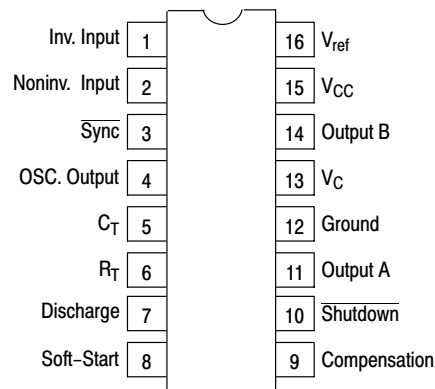

(Top View)

### ORDERING INFORMATION

See detailed ordering and shipping information in the package dimensions section on page 2 of this data sheet.

\*For additional information on our Pb-Free strategy and soldering details, please download the ON Semiconductor Soldering and Mounting Techniques Reference Manual, SOLDERRM/D.

# SG3525A

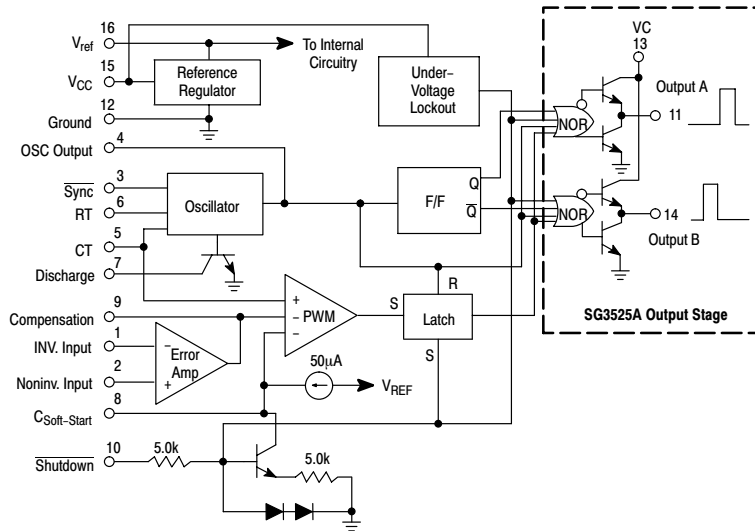

Figure 1. Representative Block Diagram

## ORDERING INFORMATION

Device	Package	Shipping†
SG3525AN	PDIP-16	25 Units / Rail
SG3525ANG	PDIP-16 (Pb-Free)	25 Units / Rail
SG3525ADW	SOIC-16L	47 Units / Rail
SG3525ADWG	SOIC-16L (Pb-Free)	47 Units / Rail
SG3525ADWR2	SOIC-16L	1000 Tape & Reel
SG3525ADWR2G	SOIC-16L (Pb-Free)	1000 Tape & Reel

†For information on tape and reel specifications, including part orientation and tape sizes, please refer to our Tape and Reel Packaging Specifications Brochure, BRD8011/D.

# SG3525A

## MAXIMUM RATINGS

Rating	Symbol	Value	Unit
Supply Voltage	$V_{CC}$	+40	Vdc
Collector Supply Voltage	$V_C$	+40	Vdc
Logic Inputs		-0.3 to +5.5	V
Analog Inputs		-0.3 to $V_{CC}$	V
Output Current, Source or Sink	$I_O$	±500	mA
Reference Output Current	$I_{ref}$	50	mA
Oscillator Charging Current		5.0	mA
Power Dissipation $T_A = +25^\circ\text{C}$ (Note 1) $T_C = +25^\circ\text{C}$ (Note 2)	$P_D$	1000 2000	mW
Thermal Resistance, Junction-to-Air	$R_{\theta JA}$	100	$^\circ\text{C}/\text{W}$
Thermal Resistance, Junction-to-Case	$R_{\theta JC}$	60	$^\circ\text{C}/\text{W}$
Operating Junction Temperature	$T_J$	+150	$^\circ\text{C}$
Storage Temperature Range	$T_{stg}$	-55 to +125	$^\circ\text{C}$
Lead Temperature (Soldering, 10 seconds)	$T_{Solder}$	+300	$^\circ\text{C}$

Maximum ratings are those values beyond which device damage can occur. Maximum ratings applied to the device are individual stress limit values (not normal operating conditions) and are not valid simultaneously. If these limits are exceeded, device functional operation is not implied, damage may occur and reliability may be affected.

1. Derate at 10 mW/ $^\circ\text{C}$  for ambient temperatures above +50 $^\circ\text{C}$ .
2. Derate at 16 mW/ $^\circ\text{C}$  for case temperatures above +25 $^\circ\text{C}$ .

## RECOMMENDED OPERATING CONDITIONS

Characteristics	Symbol	Min	Max	Unit
Supply Voltage	$V_{CC}$	8.0	35	Vdc
Collector Supply Voltage	$V_C$	4.5	35	Vdc
Output Sink/Source Current (Steady State) (Peak)	$I_O$	0 0	±100 ±400	mA
Reference Load Current	$I_{ref}$	0	20	mA
Oscillator Frequency Range	$f_{osc}$	0.1	400	kHz
Oscillator Timing Resistor	$R_T$	2.0	150	k $\Omega$
Oscillator Timing Capacitor	$C_T$	0.001	0.2	$\mu\text{F}$
Deadtime Resistor Range	$R_D$	0	500	$\Omega$
Operating Ambient Temperature Range	$T_A$	0	+70	$^\circ\text{C}$

## APPLICATION INFORMATION

### Shutdown Options (See Block Diagram, page 2)

Since both the compensation and soft-start terminals (Pins 9 and 8) have current source pull-ups, either can readily accept a pull-down signal which only has to sink a maximum of 100  $\mu\text{A}$  to turn off the outputs. This is subject to the added requirement of discharging whatever external capacitance may be attached to these pins.

An alternate approach is the use of the shutdown circuitry of Pin 10 which has been improved to enhance the available shutdown options. Activating this circuit by applying a positive signal on Pin 10 performs two functions: the PWM

latch is immediately set providing the fastest turn-off signal to the outputs; and a 150  $\mu\text{A}$  current sink begins to discharge the external soft-start capacitor. If the shutdown command is short, the PWM signal is terminated without significant discharge of the soft-start capacitor, thus, allowing, for example, a convenient implementation of pulse-by-pulse current limiting. Holding Pin 10 high for a longer duration, however, will ultimately discharge this external capacitor, recycling slow turn-on upon release.

Pin 10 should not be left floating as noise pickup could conceivably interrupt normal operation.

# SG3525A

## ELECTRICAL CHARACTERISTICS ( $V_{CC} = +20$ Vdc, $T_A = T_{low}$ to $T_{high}$ [Note 3], unless otherwise noted.)

Characteristics	Symbol	Min	Typ	Max	Unit
<b>REFERENCE SECTION</b>					
Reference Output Voltage ( $T_J = +25^\circ\text{C}$ )	$V_{ref}$	5.00	5.10	5.20	Vdc
Line Regulation ( $+8.0\text{ V} \leq V_{CC} \leq +35\text{ V}$ )	$Reg_{line}$	–	10	20	mV
Load Regulation ( $0\text{ mA} \leq I_L \leq 20\text{ mA}$ )	$Reg_{load}$	–	20	50	mV
Temperature Stability	$\Delta V_{ref}/\Delta T$	–	20	–	mV
Total Output Variation Includes Line and Load Regulation over Temperature	$\Delta V_{ref}$	4.95	–	5.25	Vdc
Short Circuit Current ( $V_{ref} = 0\text{ V}$ , $T_J = +25^\circ\text{C}$ )	$I_{SC}$	–	80	100	mA
Output Noise Voltage ( $10\text{ Hz} \leq f \leq 10\text{ kHz}$ , $T_J = +25^\circ\text{C}$ )	$V_n$	–	40	200	$\mu\text{V}_{rms}$
Long Term Stability ( $T_J = +125^\circ\text{C}$ ) (Note 4)	S	–	20	50	mV/khr

## OSCILLATOR SECTION (Note 5, unless otherwise noted.)

Initial Accuracy ( $T_J = +25^\circ\text{C}$ )		–	$\pm 2.0$	$\pm 6.0$	%
Frequency Stability with Voltage ( $+8.0\text{ V} \leq V_{CC} \leq +35\text{ V}$ )	$\frac{\Delta f_{osc}}{DV_{CC}}$	–	$\pm 1.0$	$\pm 2.0$	%
Frequency Stability with Temperature	$\frac{\Delta f_{osc}}{DT}$	–	$\pm 0.3$	–	%
Minimum Frequency ( $R_T = 150\text{ k}\Omega$ , $C_T = 0.2\text{ }\mu\text{F}$ )	$f_{min}$	–	50	–	Hz
Maximum Frequency ( $R_T = 2.0\text{ k}\Omega$ , $C_T = 1.0\text{ nF}$ )	$f_{max}$	400	–	–	kHz
Current Mirror ( $I_{RT} = 2.0\text{ mA}$ )		1.7	2.0	2.2	mA
Clock Amplitude		3.0	3.5	–	V
Clock Width ( $T_J = +25^\circ\text{C}$ )		0.3	0.5	1.0	$\mu\text{s}$
Sync Threshold		1.2	2.0	2.8	V
Sync Input Current (Sync Voltage = $+3.5\text{ V}$ )		–	1.0	2.5	mA

## ERROR AMPLIFIER SECTION ( $V_{CM} = +5.1\text{ V}$ )

Input Offset Voltage	$V_{IO}$	–	2.0	10	mV
Input Bias Current	$I_{IB}$	–	1.0	10	$\mu\text{A}$
Input Offset Current	$I_{IO}$	–	–	1.0	$\mu\text{A}$
DC Open Loop Gain ( $R_L \geq 10\text{ M}\Omega$ )	$A_{VOL}$	60	75	–	dB
Low Level Output Voltage	$V_{OL}$	–	0.2	0.5	V
High Level Output Voltage	$V_{OH}$	3.8	5.6	–	V
Common Mode Rejection Ratio ( $+1.5\text{ V} \leq V_{CM} \leq +5.2\text{ V}$ )	CMRR	60	75	–	dB
Power Supply Rejection Ratio ( $+8.0\text{ V} \leq V_{CC} \leq +35\text{ V}$ )	PSRR	50	60	–	dB

## PWM COMPARATOR SECTION

Minimum Duty Cycle	$DC_{min}$	–	–	0	%
Maximum Duty Cycle	$DC_{max}$	45	49	–	%
Input Threshold, Zero Duty Cycle (Note 5)	$V_{th}$	0.6	0.9	–	V
Input Threshold, Maximum Duty Cycle (Note 5)	$V_{th}$	–	3.3	3.6	V
Input Bias Current	$I_{IB}$	–	0.05	1.0	$\mu\text{A}$

3.  $T_{low} = 0^\circ$        $T_{high} = +70^\circ\text{C}$

4. Since long term stability cannot be measured on each device before shipment, this specification is an engineering estimate of average stability from lot to lot.

5. Tested at  $f_{osc} = 40\text{ kHz}$  ( $R_T = 3.6\text{ k}\Omega$ ,  $C_T = 0.01\text{ }\mu\text{F}$ ,  $R_D = 0\text{ }\Omega$ ).

# SG3525A

## ELECTRICAL CHARACTERISTICS (continued)

Characteristics	Symbol	Min	Typ	Max	Unit
<b>SOFT-START SECTION</b>					
Soft-Start Current ( $V_{\text{shutdown}} = 0 \text{ V}$ )		25	50	80	$\mu\text{A}$
Soft-Start Voltage ( $V_{\text{shutdown}} = 2.0 \text{ V}$ )		–	0.4	0.6	V
Shutdown Input Current ( $V_{\text{shutdown}} = 2.5 \text{ V}$ )		–	0.4	1.0	$\text{mA}$
<b>OUTPUT DRIVERS (Each Output, <math>V_{\text{CC}} = +20 \text{ V}</math>)</b>					
Output Low Level ( $I_{\text{sink}} = 20 \text{ mA}$ ) ( $I_{\text{sink}} = 100 \text{ mA}$ )	$V_{\text{OL}}$	– –	0.2 1.0	0.4 2.0	V
Output High Level ( $I_{\text{source}} = 20 \text{ mA}$ ) ( $I_{\text{source}} = 100 \text{ mA}$ )	$V_{\text{OH}}$	18 17	19 18	– –	V
Under Voltage Lockout ( $V_8$ and $V_9 = \text{High}$ )	$V_{\text{UL}}$	6.0	7.0	8.0	V
Collector Leakage, $V_{\text{C}} = +35 \text{ V}$ (Note 6)	$I_{\text{C(leak)}}$	–	–	200	$\mu\text{A}$
Rise Time ( $C_{\text{L}} = 1.0 \text{ nF}$ , $T_{\text{J}} = 25^\circ\text{C}$ )	$t_{\text{r}}$	–	100	600	ns
Fall Time ( $C_{\text{L}} = 1.0 \text{ nF}$ , $T_{\text{J}} = 25^\circ\text{C}$ )	$t_{\text{f}}$	–	50	300	ns
Shutdown Delay ( $V_{\text{DS}} = +3.0 \text{ V}$ , $C_{\text{S}} = 0$ , $T_{\text{J}} = +25^\circ\text{C}$ )	$t_{\text{ds}}$	–	0.2	0.5	$\mu\text{s}$
Supply Current ( $V_{\text{CC}} = +35 \text{ V}$ )	$I_{\text{CC}}$	–	14	20	$\text{mA}$

6. Applies to SG3525A only, due to polarity of output pulses.

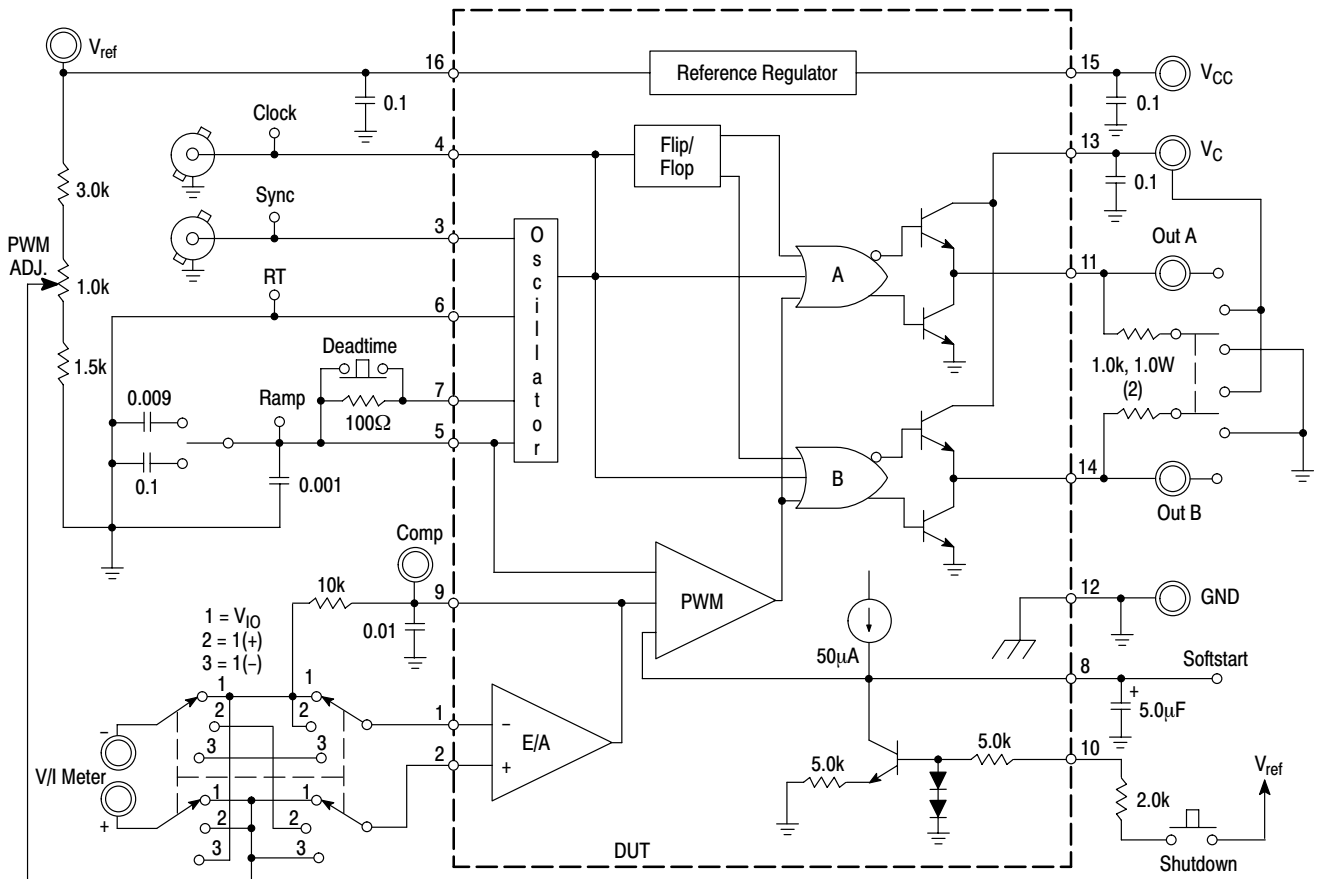
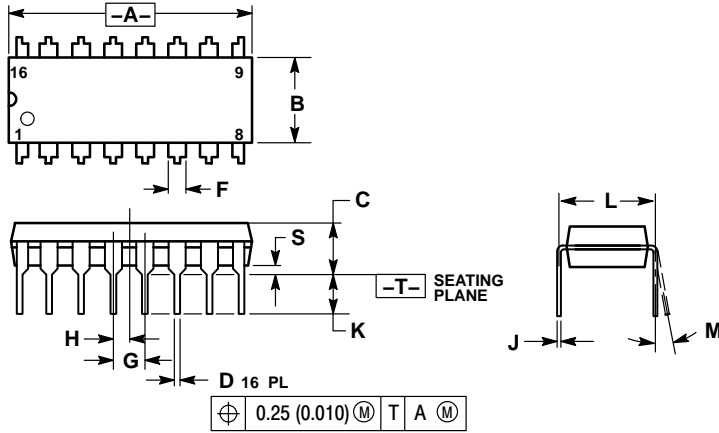

Figure 2. Lab Test Fixture

# SG3525A

## PACKAGE DIMENSIONS

PDIP-16  
N SUFFIX  
CASE 648-08  
ISSUE T



NOTES:

1. DIMENSIONING AND TOLERANCING PER ANSI Y14.5M, 1982.
2. CONTROLLING DIMENSION: INCH.
3. DIMENSION L TO CENTER OF LEADS WHEN FORMED PARALLEL.
4. DIMENSION B DOES NOT INCLUDE MOLD FLASH.
5. ROUNDED CORNERS OPTIONAL.

DIM	INCHES		MILLIMETERS	
	MIN	MAX	MIN	MAX
A	0.740	0.770	18.80	19.55
B	0.250	0.270	6.35	6.85
C	0.145	0.175	3.69	4.44
D	0.015	0.021	0.39	0.53
F	0.040	0.70	1.02	1.77
G	0.100 BSC		2.54 BSC	
H	0.050 BSC		1.27 BSC	
J	0.008	0.015	0.21	0.38
K	0.110	0.130	2.80	3.30
L	0.295	0.305	7.50	7.74
M	0°	10°	0°	10°
S	0.020	0.040	0.51	1.01