

LM211, LM311

Single Comparators

The ability to operate from a single power supply of 5.0 V to 30 V or ± 15 V split supplies, as commonly used with operational amplifiers, makes the LM211/LM311 a truly versatile comparator. Moreover, the inputs of the device can be isolated from system ground while the output can drive loads referenced either to ground, the V_{CC} or the V_{EE} supply. This flexibility makes it possible to drive DTL, RTL, TTL, or MOS logic. The output can also switch voltages to 50 V at currents to 50 mA, therefore, the LM211/LM311 can be used to drive relays, lamps or solenoids.

Features

- Pb-Free Packages are Available

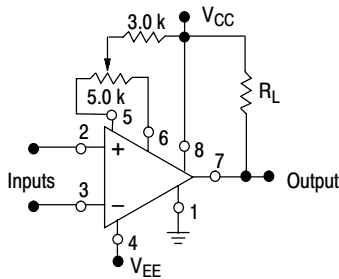

Split Power Supply with Offset Balance

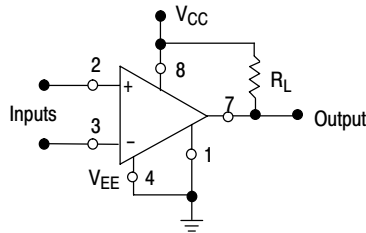

Single Supply

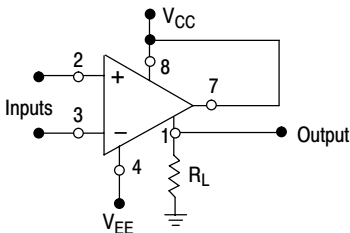

Input polarity is reversed when GND pin is used as an output.

Ground-Referred Load

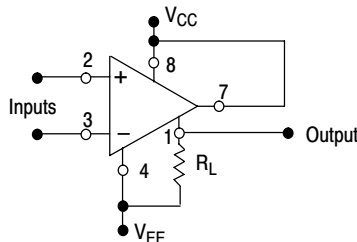

Input polarity is reversed when GND pin is used as an output.

Load Referred to Negative Supply

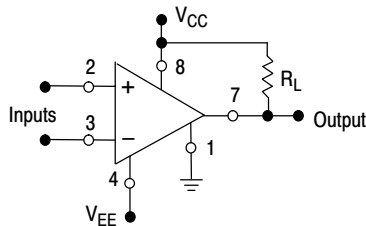

Load Referred to Positive Supply

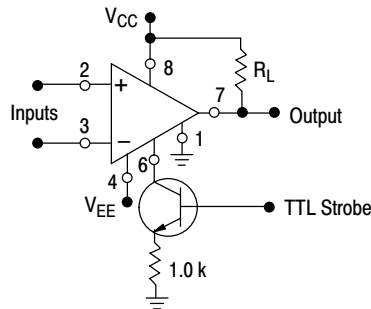

Strobe Capability

Figure 1. Typical Comparator Design Configurations



ON Semiconductor®

MARKING DIAGRAMS

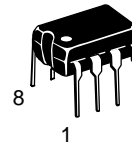

PDIP-8
N SUFFIX
CASE 626

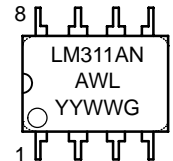

SOIC-8
D SUFFIX
CASE 751

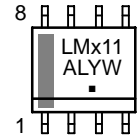

- x = 2 or 3
- A = Assembly Location
- WL, L = Wafer Lot
- YY, Y = Year
- WW, W = Work Week
- G = Pb-Free Package
- = Pb-Free Package

PIN CONNECTIONS

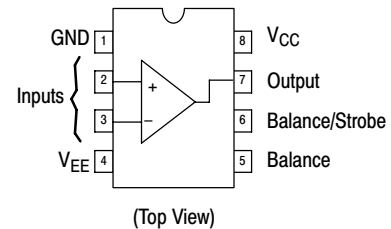

ORDERING INFORMATION

See detailed ordering and shipping information in the package dimensions section on page 2 of this data sheet.

LM211, LM311

ORDERING INFORMATION

Device	Package	Shipping†
LM211D	SOIC-8	98 Units / Rail
LM211DG	SOIC-8 (Pb-Free)	98 Units / Rail
LM211DR2	SOIC-8	2500 Units / Tape & Reel
LM211DR2G	SOIC-8 (Pb-Free)	2500 Units / Tape & Reel
LM311D	SOIC-8	98 Units / Rail
LM311DG	SOIC-8 (Pb-Free)	98 Units / Rail
LM311DR2	SOIC-8	2500 Units / Tape & Reel
LM311DR2G	SOIC-8 (Pb-Free)	2500 Units / Tape & Reel
LM311N	PDIP-8	50 Units / Rail
LM311NG	PDIP-8 (Pb-Free)	50 Units / Rail

†For information on tape and reel specifications, including part orientation and tape sizes, please refer to our Tape and Reel Packaging Specifications Brochure, BRD8011/D.

MAXIMUM RATINGS (T_A = +25°C, unless otherwise noted.)

Rating	Symbol	LM211	LM311	Unit
Total Supply Voltage	$V_{CC} + V_{EE} $	36	36	Vdc
Output to Negative Supply Voltage	$V_O - V_{EE}$	50	40	Vdc
Ground to Negative Supply Voltage	V_{EE}	30	30	Vdc
Input Differential Voltage	V_{ID}	±30	±30	Vdc
Input Voltage (Note 2)	V_{in}	±15	±15	Vdc
Voltage at Strobe Pin	-	V_{CC} to $V_{CC}-5$	V_{CC} to $V_{CC}-5$	Vdc
Power Dissipation and Thermal Characteristics Plastic DIP Derate Above T _A = +25°C	P_D $R_{\theta JA}$	625 5.0		mW mW/°C
Operating Ambient Temperature Range	T _A	-25 to +85	0 to +70	°C
Operating Junction Temperature	T _{J(max)}	+150	+150	°C
Storage Temperature Range	T _{stg}	-65 to +150	-65 to +150	°C

Maximum ratings are those values beyond which device damage can occur. Maximum ratings applied to the device are individual stress limit values (not normal operating conditions) and are not valid simultaneously. If these limits are exceeded, device functional operation is not implied, damage may occur and reliability may be affected.

LM211, LM311

ELECTRICAL CHARACTERISTICS ($V_{CC} = +15\text{ V}$, $V_{EE} = -15\text{ V}$, $T_A = 25^\circ\text{C}$, unless otherwise noted) Note 1

Characteristic	Symbol	LM211			LM311			Unit
		Min	Typ	Max	Min	Typ	Max	
Input Offset Voltage (Note 3) $R_S \leq 50\text{ k}\Omega$, $T_A = +25^\circ\text{C}$ $R_S \leq 50\text{ k}\Omega$, $T_{\text{low}} \leq T_A \leq T_{\text{high}}^*$	V_{IO}	-	0.7	3.0	-	2.0	7.5	mV
Input Offset Current (Note 3) $T_A = +25^\circ\text{C}$ $T_{\text{low}} \leq T_A \leq T_{\text{high}}^*$	I_{IO}	-	1.7	10	-	1.7	50	nA
Input Bias Current $T_A = +25^\circ\text{C}$ $T_{\text{low}} \leq T_A \leq T_{\text{high}}^*$	I_{IB}	-	45	100	-	45	250	nA
Voltage Gain	A_V	40	200	-	40	200	-	V/mV
Response Time (Note 4)		-	200	-	-	200	-	ns
Saturation Voltage $V_{ID} \leq -5.0\text{ mV}$, $I_O = 50\text{ mA}$, $T_A = 25^\circ\text{C}$ $V_{ID} \leq -10\text{ mV}$, $I_O = 50\text{ mA}$, $T_A = 25^\circ\text{C}$ $V_{CC} \geq 4.5\text{ V}$, $V_{EE} = 0$, $T_{\text{low}} \leq T_A \leq T_{\text{high}}^*$ $V_{ID} \leq 6.0\text{ mV}$, $I_{\text{sink}} \leq 8.0\text{ mA}$ $V_{ID} \leq 10\text{ mV}$, $I_{\text{sink}} \leq 8.0\text{ mA}$	V_{OL}	-	0.75	1.5	-	-	-	V
Strobe "On" Current (Note 5)	I_S	-	3.0	-	-	3.0	-	mA
Output Leakage Current $V_{ID} \geq 5.0\text{ mV}$, $V_O = 35\text{ V}$, $T_A = 25^\circ\text{C}$, $I_{\text{strobe}} = 3.0\text{ mA}$ $V_{ID} \geq 10\text{ mV}$, $V_O = 35\text{ V}$, $T_A = 25^\circ\text{C}$, $I_{\text{strobe}} = 3.0\text{ mA}$ $V_{ID} \geq 5.0\text{ mV}$, $V_O = 35\text{ V}$, $T_{\text{low}} \leq T_A \leq T_{\text{high}}^*$		-	0.2	10	-	-	-	nA
		-	-	-	-	0.2	50	nA
		-	0.1	0.5	-	-	-	μA
Input Voltage Range ($T_{\text{low}} \leq T_A \leq T_{\text{high}}^*$)	V_{ICR}	-14.5	-14.7 to 13.8	+13.0	-14.5	-14.7 to 13.8	+13.0	V
Positive Supply Current	I_{CC}	-	+2.4	+6.0	-	+2.4	+7.5	mA
Negative Supply Current	I_{EE}	-	-1.3	-5.0	-	-1.3	-5.0	mA

* LM211: $T_{\text{low}} = -25^\circ\text{C}$, $T_{\text{high}} = +85^\circ\text{C}$

LM311: $T_{\text{low}} = 0^\circ\text{C}$, $T_{\text{high}} = +70^\circ\text{C}$

- Offset voltage, offset current and bias current specifications apply for a supply voltage range from a single 5.0 V supply up to $\pm 15\text{ V}$ supplies.
- This rating applies for $\pm 15\text{ V}$ supplies. The positive input voltage limit is 30 V above the negative supply. The negative input voltage limit is equal to the negative supply voltage or 30 V below the positive supply, whichever is less.
- The offset voltages and offset currents given are the maximum values required to drive the output within a volt of either supply with a 1.0 mA load. Thus, these parameters define an error band and take into account the "worst case" effects of voltage gain and input impedance.
- The response time specified is for a 100 mV input step with 5.0 mV overdrive.
- Do not short the strobe pin to ground; it should be current driven at 3.0 mA to 5.0 mA.

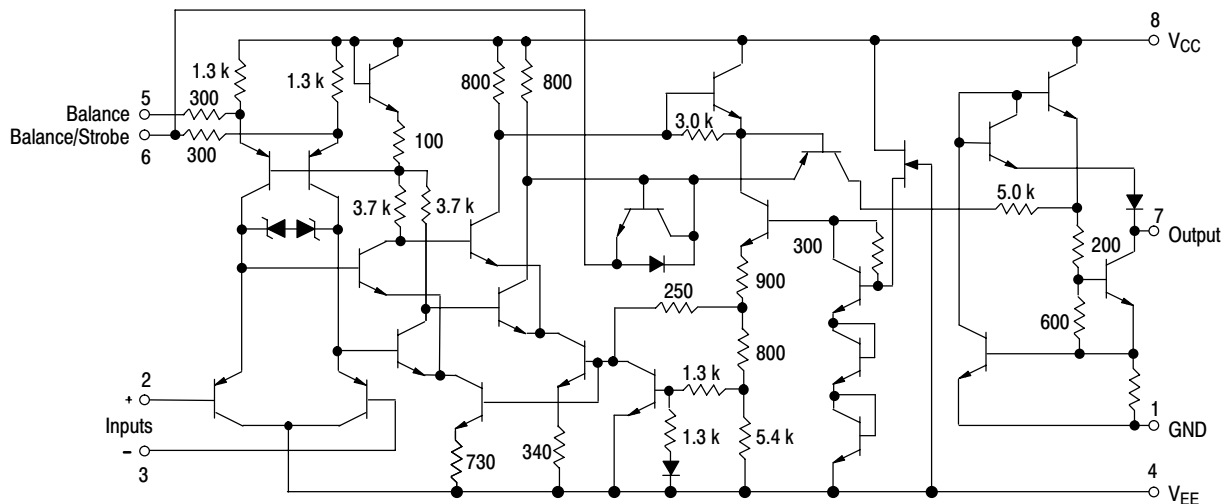
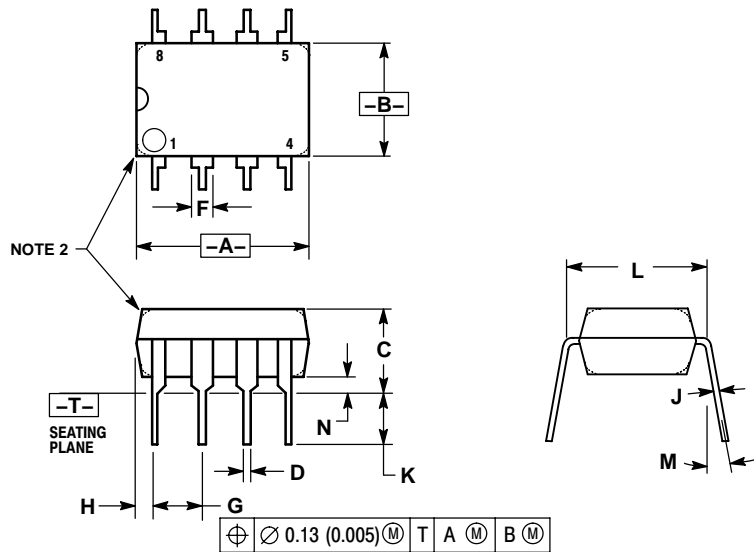

Figure 2. Circuit Schematic

LM211, LM311

PACKAGE DIMENSIONS

PDIP-8
N SUFFIX
CASE 626-05
ISSUE L



- NOTES:
1. DIMENSION L TO CENTER OF LEAD WHEN FORMED PARALLEL.
 2. PACKAGE CONTOUR OPTIONAL (ROUND OR SQUARE CORNERS).
 3. DIMENSIONING AND TOLERANCING PER ANSI Y14.5M, 1982.

DIM	MILLIMETERS		INCHES	
	MIN	MAX	MIN	MAX
A	9.40	10.16	0.370	0.400
B	6.10	6.60	0.240	0.260
C	3.94	4.45	0.155	0.175
D	0.38	0.51	0.015	0.020
F	1.02	1.78	0.040	0.070
G	2.54 BSC		0.100 BSC	
H	0.76	1.27	0.030	0.050
J	0.20	0.30	0.008	0.012
K	2.92	3.43	0.115	0.135
L	7.62 BSC		0.300 BSC	
M	---	10°	---	10°
N	0.76	1.01	0.030	0.040