

■ Features :

- Constant current design
- Universal AC input / Full range
- Fully encapsulated with IP67 level
- Withstand 300VAC surge input for 5 seconds
- Protections: Short circuit / Over current / Over voltage
- Fully isolated plastic case
- Cooling by free air convection
- UL1310 Class 2 power unit, pass LPS
- 100% full load burn-in test
- Low cost, high reliability
- Suitable for LED lighting and moving sign applications (Note.7)
- 2 years warranty

LPS IP67 (for 700mA only) US (except for 700mA)

SPECIFICATION

MODEL	LPC-35-700	LPC-35-1050	LPC-35-1400	
OUTPUT	RATED CURRENT	700mA	1050mA	1400mA
	DC VOLTAGE RANGE	9 ~ 48V	9 ~ 30V	9 ~ 24V
	RATED POWER	33.6W	31.5W	33.6W
	RIPPLE & NOISE (max.) Note.2	200mVp-p	200mVp-p	200mVp-p
	VOLTAGE TOLERANCE Note.3	±5.0%		
	LINE REGULATION	±1.0%		
	LOAD REGULATION	±2.0%		
	SETUP, RISE TIME Note.6	500ms, 120ms / 230VAC 500ms, 120ms / 115VAC at full load		
HOLD UP TIME (Typ.)	50ms/230VAC 16ms/115VAC at full load			
INPUT	VOLTAGE RANGE Note.4	90 ~ 264VAC 127 ~ 370VDC		
	FREQUENCY RANGE	47 ~ 63Hz		
	EFFICIENCY (Typ.)	85%		
	AC CURRENT	1.1A/115VAC 0.7A/230VAC		
	INRUSH CURRENT(max.)	COLD START 30A/115VAC 60A/230VAC		
LEAKAGE CURRENT	0.25mA / 240VAC			
PROTECTION	CURRENT LIMIT	±5% rated output current Protection type : Constant current limiting type		
	OVER VOLTAGE	50.4 ~ 60V	31.5 ~ 40.5V	27.6 ~ 32.4V
ENVIRONMENT	WORKING TEMP.	-30 ~ +75°C (Refer to output load derating curve)		
	WORKING HUMIDITY	20 ~ 90% RH non-condensing		
	STORAGE TEMP., HUMIDITY	-40 ~ +80°C, 10 ~ 95% RH		
	TEMP. COEFFICIENT	±0.03%/°C (0 ~ 50°C)		
	VIBRATION	10 ~ 500Hz, 2G 10min./1cycle, period for 60min. each along X, Y, Z axes		
SAFETY & EMC	SAFETY STANDARDS	UL1310 Class 2, CAN/CSA C22.2 No. 223-M91(except for LPC-35-700), IP67 approved ; design refer to TUV EN60950-1, EN61347-2-13		
	WITHSTAND VOLTAGE	I/P-O/P:3KVAC		
	ISOLATION RESISTANCE	I/P-O/P:>100M Ohms / 500VDC / 25°C / 70% RH		
	EMI CONDUCTION & RADIATION	Compliance to EN55022 (CISPR22) Class B		
	HARMONIC CURRENT	Compliance to EN61000-3-2 Class A, EN61000-3-3		
EMS IMMUNITY	Compliance to EN61000-4-2,3,4,5,6,8,11; ENV50204, EN55024, light industry level, criteria A			
OTHERS	MTBF	743.5Khrs min. MIL-HDBK-217F (25°C)		
	DIMENSION	148*40*30mm (L*W*H)		
	PACKING	0.34Kg; 40pcs/14.6Kg/0.63CUFT		
NOTE	<p>1. All parameters NOT specially mentioned are measured at 230VAC input, rated load and 25°C of ambient temperature.</p> <p>2. Ripple & noise are measured at 20MHz of bandwidth by using a 12" twisted pair-wire terminated with a 0.1uf & 47uf parallel capacitor.</p> <p>3. Tolerance : includes set up tolerance, line regulation and load regulation.</p> <p>4. Derating may be needed under low input voltage. Please check the static characteristics for more details.</p> <p>5. The power supply is considered as a component that will be operated in combination with final equipment. Since EMC performance will be affected by the complete installation, the final equipment manufacturers must re-qualify EMC Directive on the complete installation again.</p> <p>6. Length of set up time is measured at first cold start. Turning ON/OFF the power supply may lead to increase of the set up time.</p> <p>7. In the European market this power supply can be used for LED lighting applications with input power up to 25W.</p>			

■ Mechanical Specification

Case No. 975A Unit:mm

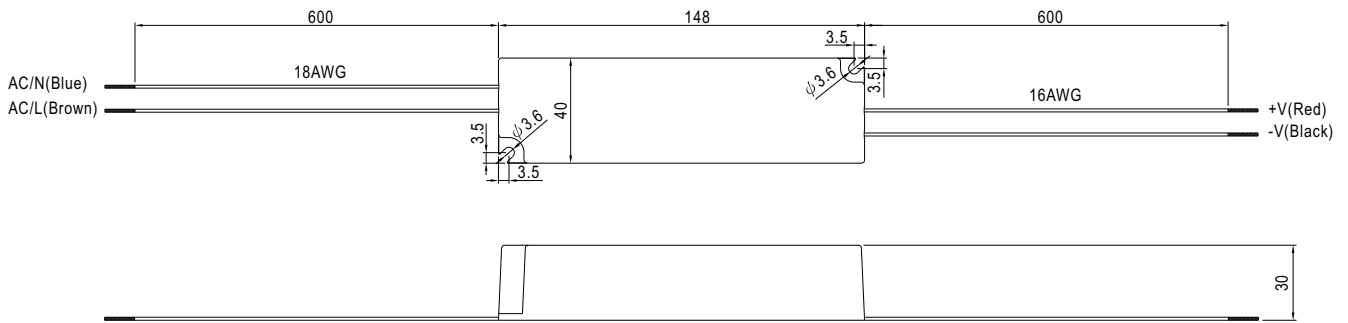

■ Block Diagram

fosc : 60KHz

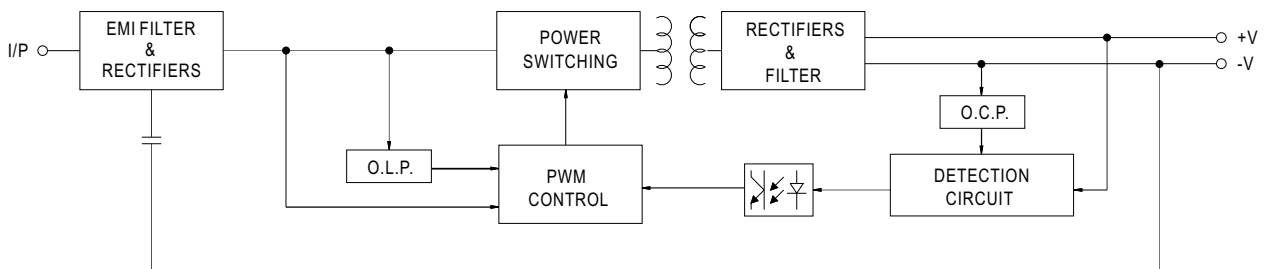

■ Derating Curve

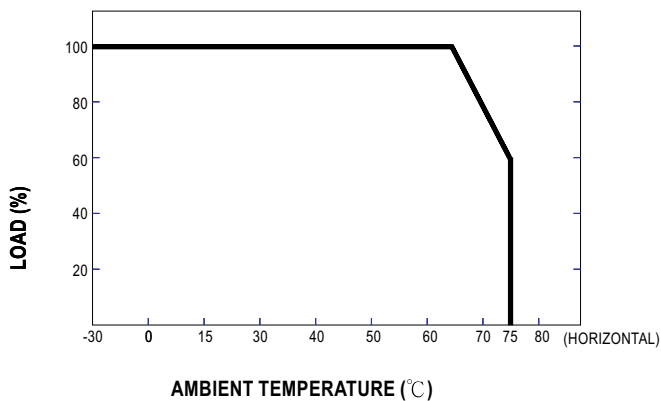

■ Static Characteristics

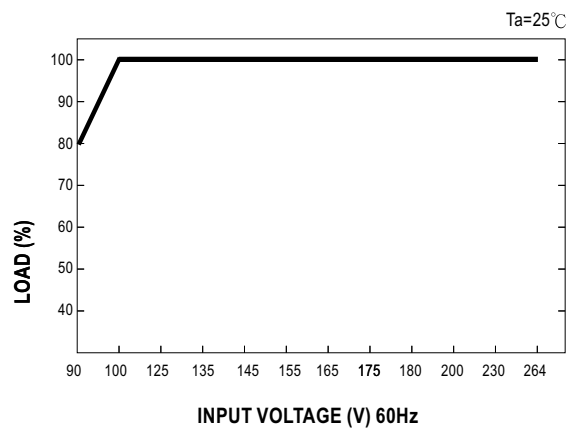

MODEL : LPC-35-1400

OUTPUT FUNCTION TEST

NO	TEST ITEM	SPECIFICATION	TEST CONDITION	RESULT	VERDICT
1	RIPPLE & NOISE	V1: 200 mVp-p (Max)	I/P: 230VAC O/P:FULL LOAD Ta:25°C	V1: 70 mVp-p (Max)	P
2	OUTPUT VOLTAGE RANGE	CH1: 9 V~ 24 V	I/P: 230 VAC I/P: 115 VAC O/P:MIN LOAD Ta:25°C	0 V~ 24.1 V/ 230 VAC 0 V~ 24.1 V/ 115 VAC	P
3	OUTPUT VOLTAGE TOLERANCE	V1: 5 %- -5 % (Max)	I/P: 100 VAC / 264 VAC O/P:FULL/ MIN LOAD Ta:25°C	V1: 0.2 %- -0.2 %	P
4	LINE REGULATION	V1: 1 %- -1 % (Max)	I/P: 100VAC ~ 264 VAC O/P:FULL LOAD Ta:25°C	V1: 0 %- 0 %	P
5	LOAD REGULATION	V1: 2 %- 2 % (Max)	I/P: 230 VAC O/P:FULL ~MIN LOAD Ta:25°C	V1: 0.2 %- -0.2 %	P
6	SET UP TIME	230VAC: 500 ms (Max) 115 VAC: 500 ms (Max)	I/P: 230 VAC I/P: 115 VAC O/P:FULL LOAD Ta:25°C	230VAC/ 139 ms 115VAC/ 1.03 ms	P
7	RISE TIME	230VAC: 120 ms (Max) 115VAC: 120 ms (Max)	I/P: 230 VAC I/P: 115 VAC O/P:FULL LOAD Ta:25°C	230VAC/ 18 ms 115VAC/ 16 ms	P
8	HOLD UP TIME	230VAC: 50 ms (TYP) 115VAC: 16 ms (TYP)	I/P: 230 VAC I/P: 115 VAC O/P:FULL LOAD Ta:25°C	230VAC/ 138 ms 115VAC/ 30 ms	P
9	OVER/UNDERSHOOT TEST	< ±5%	I/P: 230 VAC O/P:FULL LOAD Ta:25°C	TEST: <5 %	P
10	DYNAMIC LOAD	V1: 2400 mVp-p	I/P: 230 VAC O/P:FULL /Min LOAD 90%DUTY/1KHZ Ta:25°C	299 mVp-p	P

INPUT FUNCTION TEST

NO	TEST ITEM	SPECIFICATION	TEST CONDITION	RESULT	VERDICT
1	INPUT VOLTAGE RANGE	90VAC~264 VAC	I/P:TESTING O/P:FULL LOAD Ta:25°C	52 V~264V	P
			I/P: LOW-LINE-3V= 87 V HIGH-LINE+15%=300 V O/P:FULL/MIN LOAD ON: 30 Sec . OFF: 30 Sec 10MIN (AC POWER ON/OFF NO DAMAGE)	TEST: OK	
2	INPUT FREQUENCY RANGE	47HZ ~63 HZ NO DAMAGE OSC	I/P:100 VAC ~ 264 VAC O/P:FULL~MIN LOAD Ta:25°C	TEST: OK	P
3	EFFICIENCY	85% (TYP)	I/P: 230 VAC O/P:FULL LOAD Ta:25°C	86.2%	P
4	INPUT CURRENT	230V/ 0.7 A (TYP) 115V/ 1.1 A (TYP)	I/P: 230 VAC I/P: 115 VAC O/P:FULL LOAD Ta:25°C	I = 0.3 A/ 230 VAC I = 0.5 A/ 115 VAC	P
5	INRUSH CURRENT	230V/ 60 A (TYP) 115V/ 30 A (TYP) COLD START	I/P: 230 VAC I/P: 115 VAC O/P:FULL LOAD Ta:25°C	I = 48 A/ 230 VAC I = 24 A/ 115 VAC	P
6	LEAKAGE CURRENT	< 0.25 mA / 240 VAC	I/P: 264 VAC O/P:Min LOAD Ta:25°C	L-FG: 0.01 mA N-FG: 0.01 mA	P

PROTECTION FUNCTION TEST

NO	TEST ITEM	SPECIFICATION	TEST CONDITION	RESULT	VERDICT
1	CURRENT LIMIT	95 %- 105 %	I/P: 230 VAC I/P: 115 VAC O/P:TESTING Ta:25°C	100 %/ 230 VAC 100%/ 115 VAC Constant Current Limiting	P
2	OVER VOLTAGE PROTECTION	CH1:27.6 V~ 32.4 V	I/P: 230 VAC I/P: 115 VAC O/P:MIN LOAD Ta:25°C	30V/ 230 VAC 30V/ 115 VAC Shut down Re- power ON	P
3	SHORT PROTECTION	SHORT EVERY OUTPUT 1 HOUR NO DAMAGE	I/P: 264 VAC O/P:FULL LOAD Ta:25°C	NO DAMAGE Constant Current Limiting	P

ENVIRONMENT TEST

NO	TEST ITEM	SPECIFICATION	TEST CONDITION	RESULT	VERDICT
1	TEMPERATURE RISE TEST	MODEL : LPC-35-1400 1. ROOM AMBIENT BURN-IN : 3 HRS I/P: 230VAC O/P: FULL LOAD Ta=29 °C 2. HIGH AMBIENT BURN-IN : 1 HRS I/P: 230VAC O/P: FULL LOAD Ta=62.9 °C			P
2	OVER LOAD BURN-IN TEST	NO DAMAGE 1 HOUR (MIN)	I/P: 230 VAC O/P:101 % LOAD Ta:29.1°C	TEST : OKO	P
3	LOW TEMPERATURE TURN ON TEST	TURN ON AFTER 2 HOUR	I/P: 230 VAC O/P: 95 % LOAD Ta= -35 °C	TEST : OK	P
4	HIGH HUMIDITY HIGH TEMPERATURE HIGH VOLTAGE TURN ON TEST	AFTER 12 HOURS IN CHAMBER ON CONTROL 65°C NO DAMAGE	I/P: 272 VAC O/P:95% LOAD Ta= 65 °C HUMIDITY= 95 %R.H	TEST : OK	P
5	TEMPERATURE COEFFICIENT	± 0.03 %(0-50°C)	I/P: 230 VAC O/P:FULL LOAD	± 0.002 %(0-50°C)	P
6	VIBRATION TEST	1 Carton & 1 Set (1) Waveform: Sine Wave (2) Frequency:10-500Hz (3) Sweep Time:10min/sweep cycle (4) Acceleration:2G (5) Test Time:1 hour in each axis (X.Y.Z) (6) Ta:25°C		TEST : OK	P

SAFETY TEST

NO	TEST ITEM	SPECIFICATION	TEST CONDITION	RESULT	VERDICT
1	WITHSTAND VOLTAGE	I/P-O/P: 3 KVAC/min	I/P-O/P: 3.6 KVAC/min	I/P-O/P: 1.940 mA NO DAMAGE	P
2	ISOLATION RESISTANCE	I/P-O/P:500VDC>100MΩ	I/P-O/P: 500 VDC Ta:25°C / 70%RH	I/P-O/P: 10.21 GΩ NO DAMAGE	P
3	APPROVAL	TUV: Certificate NO : UL: File NO :			N/A

E.M.C TEST

NO	TEST ITEM	SPECIFICATION	TEST CONDITION	RESULT	VERDICT
1	HARMONIC	EN61000-3-2 CLASS A	I/P: 230/240/220 VAC/50HZ O/P:100/75/50/25% LOAD Ta:25°C	PASS	P
2	CONDUCTION	EN55022 CLASS B	I/P: 230 VAC (50HZ)/115V(60HZ) O/P:FULL/50% LOAD Ta:25°C	PASS Test by certified Lab	P
3	RADIATION	EN55022 CLASS B	I/P: 230 VAC (50HZ)/115V(60HZ) O/P:FULL LOAD Ta:25°C	PASS Test by certified Lab	P
4	E.S.D	EN61000-4-2 LIGHT INDUSTRY AIR:8KV / Contact:4KV	I/P: 230 VAC/50HZ O/P:FULL LOAD Ta:25°C	CRITERIA A	P
5	E.F.T	EN61000-4-4 LIGHT INDUSTRY INPUT: 1KV	I/P: 230 VAC/50HZ O/P:FULL LOAD Ta:25°C	CRITERIA A	P
6	SURGE	IEC61000-4-5 LIGHT INDUSTRY L-N :1KV L,N-PE:2KV	I/P: 230 VAC/50HZ O/P:FULL LOAD Ta:25°C	CRITERIA A	P
7	Test by certified Lab & Test Report Prepare				

M.T.B.F & LIFE CYCLE CALCULATION

NO	TEST ITEM	SPECIFICATION	TEST CONDITION	RESULT	VERDICT
1	CAPACITOR LIFE CYCLE	LPC-35-1400:SUPPOSE C105 IS THE MOST CRITICAL COMPONENT	I/P: 230VAC O/P:FULL LOAD Ta=25 °C LIFE TIME= 212352 HRS I/P: 230VAC O/P:FULL LOAD Ta=65 °C LIFE TIME= 27888 HRS		P
2	MTBF	MIL-HDBK-217F NOTICES2 PARTS COUNT TOTAL FAILURE RATE: 743.5 K HRS			P
3	ORT (Ongoing Reliability test)	LPC-35-1400:I/P : 230VAC O/P : 95% LOAD TA=50°C Sample=10pcs	TEST TIME=2856HRS		P

COMPONENT STRESS TEST

NO	TEST ITEM	SPECIFICATION	TEST CONDITION	RESULT	VERDICT
1	Power Transistor (D to S) or (C to E) Peak Voltage	Q1 Rated STF6NM60N :600 V/ 4.6A	I/P:High-Line +3V = 267 V O/P: (1)Full Load Turn on (2) Output Short Ta:25°C	(1) 586 V (2) 456 V	P
2	Diode Peak Voltage	D100Rated FMX-12SL 10A/200V	I/P:High-Line +3V = 267 V O/P: (1)Full Load Turn on (2)Output Short Ta:25°C	(1) 190 V (2) 180 V	P
3	Clamp Diode Peak Voltage	D1 Rated EGP20J : 2A/600V	I/P:High-Line +3V = 267 V O/P: (1) Dynamic Load 90%Duty/1KHz Ta:25°C	(1) 496 V	P
4	Input Capacitor Voltage	C5 Rated 120u/400V 105°C KMG	I/P:High-Line +3V = 267 V O/P: (1)Full Load Turn on /Off (2) Min load Turn on /Off (3)Full Load /Min load Change Ta:25°C	(1) 370 V (2) 378 V (3) 378 V	P
5	Control IC Voltage Test	U1 NCP1200/ 18V	I/P:High-Line +3V = 267 V O/P: (1)Full Load Turn on /Off (2) Min load Turn on /Off (3)Full Load /Min load Change Ta:25°C	(1) 11.36 V (2) 10.24 V (3) 11.36 V	P

DATE	SAMPLE	TEST RESULT	TESTER	APPROVAL
2008/5/5	RD SAMPLE	PASS	SANFORD SU	VINCENT TSENG
2008/9/4	PRODUCT SAMPLE W0806C09	PASS	SANFORD SU	VINCENT TSENG
2008/11/10	PRODUCT SAMPLE W0809E05	PASS	SANFORD SU	VINCENT TSENG

2003/12/12 A50-F023