

Distributed by:

JAMECO[®]
ELECTRONICS

www.Jameco.com ♦ 1-800-831-4242

The content and copyrights of the attached
material are the property of its owner.

Jameco Part Number 883405

FEATURES AND SPECIFICATIONS

Features and Benefits

- Snap-in peg locks header to PCB for optimum retention
- Fully polarized to mating receptacle
- Surface Mount Compatible

Reference Information

Product Specification: PS-43045
 Packaging: Tray
 UL File No.: E29179
 CSA File No.: LR19980
 TUV License No.: R95107
 Mates With: [43025](#)
 Designed In: Millimeters

Electrical

Voltage: 250V
 Current: 5.0A max.
 Contact Resistance: 10mΩ max.
 Dielectric Withstanding Voltage: 1500V AC
 Insulation Resistance: 1000 MΩ min.

Mechanical

Insertion Force to PCB: 7.5kgf max. (16.5 lb)

Physical

Housing: High temperature LCP, UL 94V-0
 Contact: Brass
 Plating: Tin or Gold



3.00mm (.118") Pitch Micro-Fit 3.0™ Wire-to-Board Header

43045 Dual Row Right Angle

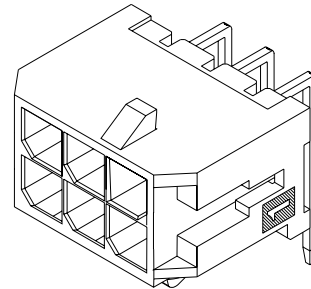

CATALOG DRAWING (FOR REFERENCE ONLY)

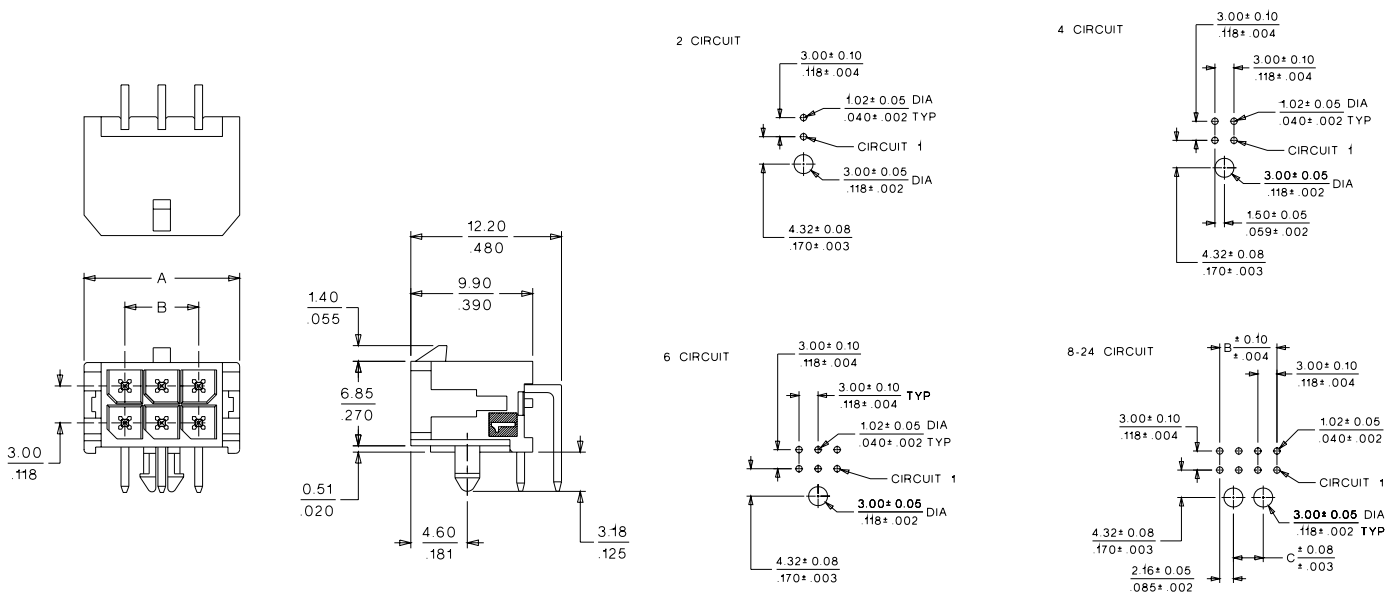

ORDERING INFORMATION AND DIMENSIONS

Circuits	Order No.			Dimension		
	Tin	15μ" Gold	30μ" Gold	A	B	C
2	• 43045-0200	43045-0201	• 43045-0202	6.65 (.262)		
4	• 43045-0400	43045-0401	• 43045-0402	9.65 (.380)	3.00 (.118)	
6	• 43045-0600	43045-0601	• 43045-0602	12.65 (.498)	6.00 (.236)	
8	• 43045-0800	43045-0801	• 43045-0802	15.65 (.616)	9.00 (.354)	4.70 (.185)
10	• 43045-1000	43045-1001	• 43045-1002	18.65 (.734)	12.00 (.472)	7.70 (.303)
12	• 43045-1200	43045-1201	• 43045-1202	21.65 (.852)	15.00 (.591)	10.70 (.421)
14	• 43045-1400	43045-1401	• 43045-1402	24.65 (.970)	18.00 (.709)	13.70 (.539)
16	• 43045-1600	43045-1601	• 43045-1602	27.65 (1.088)	21.00 (.827)	16.70 (.657)
18	• 43045-1800	43045-1801	• 43045-1802	30.65 (1.206)	24.00 (.945)	19.70 (.776)
20	• 43045-2000	43045-2001	• 43045-2002	33.65 (1.325)	27.00 (1.063)	22.70 (.894)
22	• 43045-2200	43045-2201	• 43045-2202	36.65 (1.443)	30.00 (1.181)	25.70 (1.012)
24	• 43045-2400	43045-2401	• 43045-2402	39.65 (1.561)	33.00 (1.299)	28.70 (1.130)

• US Standard Product, available through Molex franchised distributors



PRODUCT SPECIFICATION

MICRO-FIT

1.0 SCOPE

This Product Specification covers the 3.00 mm (.118 inch) centerline (pitch) square pin headers when mated with either printed circuit board (PCB) connector or connectors terminated with 20 to 30 AWG wire using crimp technology.

2.0 PRODUCT DESCRIPTION

2.1 PRODUCT NAME AND SERIES NUMBERS

Receptacle: 43025 Terminal: 43030
Plug: 43020 Terminal: 43031
Headers: 43045, 44914

Test Plug: 44242 (recommended for continuity testing only)

Other products conforming to this specification are noted on the individual drawings.

2.2 DIMENSIONS, MATERIALS, PLATINGS AND MARKINGS

Housings: Polyester or LCP
Terminal: Phosphor Bronze
Pins: Brass, Modified Tin/Brass

2.3 SAFETY AGENCY APPROVALS

UL File Number: E29179
CSA: LR19980
TUV: 72040445

3.0 APPLICABLE DOCUMENTS AND SPECIFICATIONS

Test Summary: TS-43045-001

4.0 RATINGS

4.1 VOLTAGE

UL: 250 Volts AC (MAX) {or 176 Volts DC}
TUV: 250 Volts

4.2 CURRENT AND APPLICABLE WIRES (Current is dependent on connector size, contact material, plating, ambient temperature, printed circuit board characteristics and related factors. Actual current rating is application dependent and should be evaluated for each application.)

AWG	Amps	Max. Outside Insulation Diameter
20	5	1.85 mm (.073 inch)
22	5	1.85 mm (.073 inch)
24	4	1.85 mm (.073 inch)
26	3	1.27 mm (.050 inch)
28	2	1.27 mm (.050 inch)
30	1	1.27 mm (.050 inch)

4.2.1 CURRENT FOR TEST PLUG 44242

2.5 Amps Maximum (Pogo pin current capacity)

(Test plugs are for testing purposes only and not intended for continuous use.)

4.3 TEMPERATURE

Operating: - 40°C to + 105°C (Including Terminal Temperature Rise)
Nonoperating: - 40°C to + 105°

REVISION: K	EGR/ECN INFORMATION: EC No: UCP2007-0365 DATE: 2006/08/08	TITLE: PRODUCT SPECIFICATION MICRO-FIT DUAL ROW CONNECTORS	SHEET No. 1 of 5
DOCUMENT NUMBER: PS-43045	CREATED / REVISED BY: M.KIPPER	CHECKED BY: S.SOUSEK	APPROVED BY: F.SMITH



PRODUCT SPECIFICATION

5.0 PERFORMANCE

5.1 ELECTRICAL REQUIREMENTS

DESCRIPTION	TEST CONDITION	REQUIREMENT
Contact Resistance (Low Level)	Mate connectors: apply a maximum voltage of 20 mV and a current of 100 mA. (Does not include wire resistance)	10 milliohms MAXIMUM [initial]
Contact Resistance @ Rated Current	Mate connectors: apply a maximum voltage of 20 mV at rated current.	30 milliohms MAXIMUM [initial]
Contact Resistance of Wire Termination (Low Level)	Terminate the applicable wire to the terminal and measure wire using a voltage of 20 mV and a current of 100 mA.	5 milliohms MAXIMUM [initial]
Insulation Resistance	Unmate & unmount connectors: apply a voltage of 500 VDC between adjacent terminals and between terminals to ground.	1000 Megohms MINIMUM
Dielectric Withstanding Voltage	Unmate connectors: apply a voltage of {two times the rated voltage plus 1000 volts} VAC for 1 minute between adjacent terminals and between terminals to ground.	No breakdown; current leakage < 5 mA
Capacitance	Measure between adjacent terminals at 1 MHz.	2 picofarads MAXIMUM
Temperature Rise (via Current Cycling)	Mate connectors: measure the temperature rise at the rated current after: 1) 96 hours (steady state) 2) 240 hours (45 minutes ON and 15 minutes OFF per hour) 3) 96 hours (steady state)	Temperature rise: +30°C MAXIMUM

5.2 MECHANICAL REQUIREMENTS

DESCRIPTION	TEST CONDITION	REQUIREMENT
Connector Mate and Unmate Forces	Mate and unmate connector (male to female) at a rate of 25 ± 6 mm (1 ± ¼ inch) per minute. (Per circuit)	8.0 N (1.8 lbf) MAXIMUM insertion force & 3.7 N (0.8 lbf) MINIMUM withdrawal force
Terminal Retention Force (in Housing)	Axial pullout force on the terminal in the housing at a rate of 25 ± 6 mm (1 ± ¼ inch) per minute.	24.5 N (5.5 lbf) MINIMUM retention force
Terminal Insertion Force (into Housing)	Apply an axial insertion force on the terminal at a rate of 25 ± 6 mm (1 ± ¼ inch).	14.7 N (3.3 lbf) MAXIMUM insertion force

REVISION: K	EGR/ECN INFORMATION: EC No: UCP2007-0365 DATE: 2006/08/08	TITLE: PRODUCT SPECIFICATION MICRO-FIT DUAL ROW CONNECTORS	SHEET No. 2 of 5
DOCUMENT NUMBER: PS-43045	CREATED / REVISED BY: M.KIPPER	CHECKED BY: S.SOUSEK	APPROVED BY: F.SMITH



PRODUCT SPECIFICATION

5.2 MECHANICAL REQUIREMENTS

Durability	Mate connectors up to 30 cycles at a maximum rate of 10 cycles per minute prior to Environmental Tests.	20 milliohms MAXIMUM (change from initial)
Vibration (Random)	Mate connectors and vibrate per EIA 364-28, test condition VII.	20 milliohms MAXIMUM (change from initial) & Discontinuity < 1 microsecond
Shock (Mechanical)	Mate connectors and shock at 50 g's with 1/2 sine wave (11 milliseconds) shocks in the ±X,±Y,±Z axes (18 shocks total).	20 milliohms MAXIMUM (change from initial) & Discontinuity < 1 microsecond
Wire Pullout Force (Axial) (Wire from Terminal)	Apply an axial pullout force on the wire at a rate of 25 ± 6 mm (1 ± 1/4 inch).	MINIMUM pullout force 20 awg: 57.8 N (13.0 lbf) 22 awg: 35.6 N (8.0 lbf) 24 awg: 22.2 N (5.0 lbf) 26 awg: 13.3 N (3.0 lbf) 28 awg: 8.9 N (2.0 lbf) 30 awg: 6.6 N (1.5 lbf)
Normal Force	Apply a perpendicular force.	2.7 N (275 grams) MINIMUM
Pin to Header Retention	Apply axial push force to pin at a rate of 25 ± 6 mm (1 ± 1/4 inch) per minute.	13.7 N (3.1 lbf) MINIMUM pushout force
Thumb Latch to Ramp Yield Strength	Full mate and then Unmate the connectors at a rate of 25 ± 6 mm (1 ± 1/4 inch) per minute.	68.4 N (15.4 lbf) MINIMUM Yield Strength
Panel Mount Retention	Full mate and then Unmate the connectors at a rate of 25 ± 6 mm (1 ± 1/4 inch) per minute.	155.7 N (35 lbf) MINIMUM pushout force
Compliant Pin Insertion Force into PCB Hole (44914 Series)	Apply an axial insertion force on the terminal at a rate of 25 ± 6 mm (1 ± 1/4 inch).	106.7 N (24 lbf) MAXIMUM Insertion force (Per Terminal)
Compliant Pin Retention Force in PCB Hole (44914 Series)	Apply an axial extraction force on the terminal at a rate of 25 ± 6 mm (1 ± 1/4 inch).	35.6 N (8 lbf) MINIMUM Retention force (Per Terminal)

REVISION: K	EGR/ECN INFORMATION: EC No: UCP2007-0365 DATE: 2006/08/08	TITLE: PRODUCT SPECIFICATION MICRO-FIT DUAL ROW CONNECTORS	SHEET No. 3 of 5
DOCUMENT NUMBER: PS-43045	CREATED / REVISED BY: M.KIPPER	CHECKED BY: S.SOUSEK	APPROVED BY: F.SMITH



PRODUCT SPECIFICATION

5.3 ENVIRONMENTAL REQUIREMENTS

DESCRIPTION	TEST CONDITION	REQUIREMENT
Thermal Aging	Mate connectors; expose to: 240 hours at 105 ± 2°C OR 500 hours at 85 ± 2°C	20 milliohms MAXIMUM (change from initial)]
Humidity (Steady State)	Mate connectors: expose to a temperature of 40 ± 2°C with a relative humidity of 90-95% for 96 hours. Note: Remove surface moisture and air dry for 1 hour prior to measurements.	20 milliohms MAXIMUM (change from initial) & Dielectric Withstanding Voltage: No Breakdown at 500 VAC & Insulation Resistance: 1000 Megohms MINIMUM
Solderability	Per SMES-152	Solder coverage: 95% MINIMUM (per SMES-152)
Solder Resistance	A) Wave Solder Process Dip connector terminal tails in solder; Solder Duration: 5 ± 0.5 seconds; Solder Temperature: 260°C MAX B) Convection Reflow Solder Process 235°C MAX Per SMES-152	Visual: No Damage to insulator material
Cold Resistance	Mate connectors: Duration: 96 hours; Temperature: -40 ± 3°C	20 milliohms MAXIMUM (change from initial)
Corrosive Atmosphere: Sulfur Dioxide Gas (SO₂)	Mate connectors: Duration: 24 hours exposure; Atmosphere: 50 parts per million (ppm) SO ₂ gas; Temperature: 40 ± 3°C	20 milliohms MAXIMUM (change from initial)
Corrosive Atmosphere: Ammonia Gas (NH₃)	Mate connectors: Duration: 40 minutes exposure; Atmosphere: NH ₃ gas evaporating from a 28% Ammonia solution	20 milliohms MAXIMUM (change from initial)

REVISION: K	ECR/ECN INFORMATION: EC No: UCP2007-0365 DATE: 2006/08/08	TITLE: PRODUCT SPECIFICATION MICRO-FIT DUAL ROW CONNECTORS	SHEET No. 4 of 5
DOCUMENT NUMBER: PS-43045	CREATED / REVISED BY: M.KIPPER	CHECKED BY: S.SOUSEK	APPROVED BY: F.SMITH



PRODUCT SPECIFICATION

6.0 PACKAGING

Parts shall be packaged to protect against damage during handling, transit and storage per the packaging specifications listed below:

Receptacle: PK-43025-001

Plug: PK-43020-001

Headers: PK-70873-0313, PK-70873-0314, PK-70873-05**.

7.0 GAGES AND FIXTURES

It is recommended that test plugs (Series 44242) be used for continuity testing of receptacles. Standard mating parts should not be used for harness testing.

8.0 OTHER INFORMATION

8.1 CABLE TIE AND OR WIRE TWIST LOCATION

CKT Sizes	Dim T	Min.
2-8	.500	(12.70)
10-16	.750	(19.10)
18-24	1.000	(25.40)

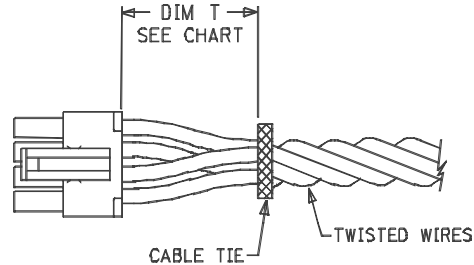

REVISION: K	EGR/ECN INFORMATION: EC No: UCP2007-0365 DATE: 2006/08/08	TITLE: PRODUCT SPECIFICATION MICRO-FIT DUAL ROW CONNECTORS	SHEET No. 5 of 5
DOCUMENT NUMBER: PS-43045	CREATED / REVISED BY: M.KIPPER	CHECKED BY: S.SOUSEK	APPROVED BY: F.SMITH

43045			
CKTS	A	B	C
02	.262 6.65	NA	NA
04	.380 9.65	.118 3.00	NA
06	.498 12.65	.236 6.00	NA
08	.616 15.65	.354 9.00	.185 4.70
10	.734 18.65	.472 12.00	.303 7.70
12	.852 21.65	.591 15.00	.421 10.70
14	.970 24.65	.709 18.00	.539 13.70
16	1.088 27.65	.827 21.00	.657 16.70
18	1.206 30.65	.945 24.00	.776 19.70
20	1.325 33.65	1.063 27.00	.894 22.70
22	1.443 36.65	1.181 30.00	1.012 25.70
24	1.561 39.65	1.299 33.00	1.130 28.70

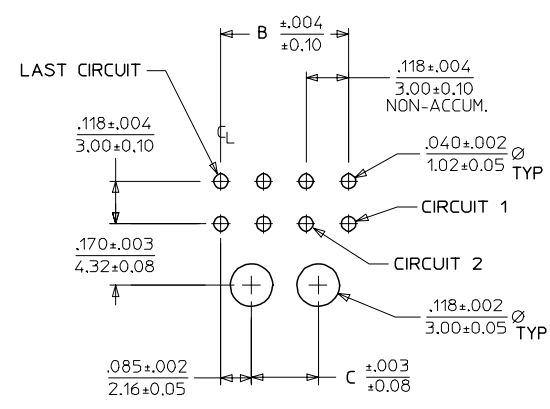

PCB LAYOUT: COMPONENT SIDE
RECOMMEND PCB THICKNESS: .062/1.57

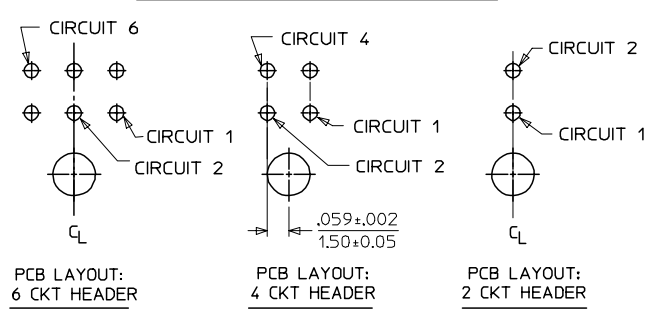

	FINISH A	FINISH B	FINISH C
CKTS	MATERIAL NO:	MATERIAL NO:	MATERIAL NO:
02	43045-0200	43045-0201	43045-0202
04	43045-0400	43045-0401	43045-0402
06	43045-0600	43045-0601	43045-0602
08	43045-0800	43045-0801	43045-0802
10	43045-1000	43045-1001	43045-1002
12	43045-1200	43045-1201	43045-1202
14	43045-1400	43045-1401	43045-1402
16	43045-1600	43045-1601	43045-1602
18	43045-1800	43045-1801	43045-1802
20	43045-2000	43045-2001	43045-2002
22	43045-2200	43045-2201	43045-2202
24	43045-2400	43045-2401	43045-2402

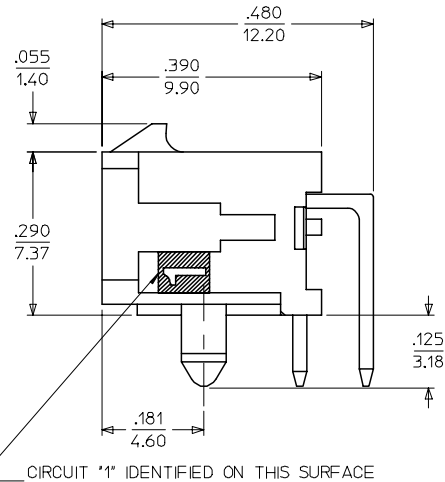
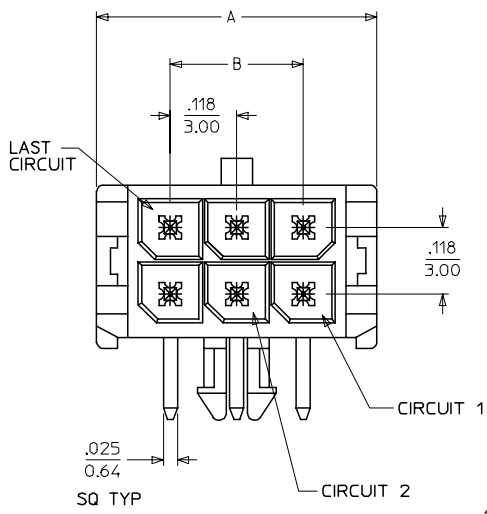
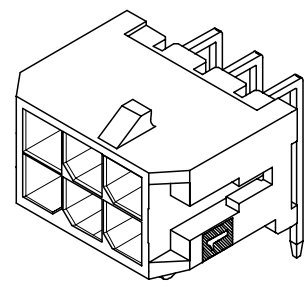
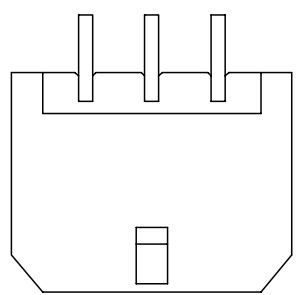

CIRCUIT *1* IDENTIFIED ON THIS SURFACE
(APPROX. LOCATION SHOWN FOR REF.)

NOTES:

- HOUSING MATERIAL: GLASS FILLED LIQUID CRYSTAL POLYMER, UL94V-0, COLOR: BLACK
TERMINAL MATERIAL: BRASS ALLOY
- FINISH:
 - A = .000100/(0.00254) MIN. TIN OVER
.000050/(0.00127) MIN. NICKEL PLATE.
 - B = .000015/(0.00038) MIN. SELECT GOLD IN CONTACT AREA,
.000100/(0.00254) MIN. SELECT TIN ON SOLDER TAILS,
BOTH OVER .000050/(0.00127) MIN. NICKEL PLATE.
 - C = .000030/(0.00076) MIN. SELECT GOLD IN CONTACT AREA,
.000100/(0.00254) MIN. SELECT TIN ON SOLDER TAILS,
BOTH OVER .000050/(0.00127) MIN. NICKEL PLATE.
- THE PRIMARY SHIPPING CARTON WILL BE LABELED "COMPLIANT TO RoHS DIRECTIVE 2002/95/EC AND ELV ANNEX II OF DIRECTIVE 2000/53/EC." CARTONS WITHOUT THIS LABEL MAY CONTAIN PRODUCT WITH TIN/LEAD IN THE PC TAIL AREA.
- PRODUCT SPECIFICATION: PS-43045
- MATES WITH MICRO FIT (3.0) RECEPTACLE SERIES 43025
- TRAY PACKAGED : SEE MOLEX DRAWING PK-70873-0313

CHANGED *1* LOCATION EC NO: UCP2006-1962 DRWN:PRDIER 2006/03/30 CHKD:SSOUSEK 2006/03/31 APPR:FSMITH 2006/04/03	QUALITY SYMBOLS	GENERAL TOLERANCES (UNLESS SPECIFIED)	SCALE ---	DESIGN UNITS METRIC	THIRD ANGLE PROJECTION	REVISE ON CAD ONLY	
	-0 -0	mm	INCH	DIMENSION STYLE IN/MM	TITLE		
		4 PLACES ± --- ± ---	3 PLACES ± --- ± .010	DRAWN BY SAMIEC	DATE 2000/03/15	MICRO-FIT (3.0) DUAL ROW RIGHT ANGLE THRU HOLE HEADER ASS'Y	
		2 PLACES ± 0.25 ± .014	1 PLACE ± 0.36 ± ---	CHECKED BY MUELLER	DATE 2000/03/15	MOLEX MOLEX INCORPORATED	
D1	ANGULAR ±1/2°	DRAFT WHERE APPLICABLE	APPROVED BY EDGLEY	DATE 2000/03/15	MATERIAL NO. SEE CHART	DOCUMENT NO. SD-43045-001	
		MUST REMAIN WITHIN DIMENSIONS	THIS DRAWING CONTAINS INFORMATION THAT IS PROPRIETARY TO MOLEX INCORPORATED AND SHOULD NOT BE USED WITHOUT WRITTEN PERMISSION				