

5

4

3

2

1

受控 CONTROLLED DOCUMENT

编号 P/N	CPFIUG882-CUST	版本 Rev	01	日期 Rel'd Date	Apr29,09
-----------	----------------	-----------	----	------------------	----------

DRAWING NO.

CPFIUG882-CUST

REVISIONS

01	OFFICIAL RELEASE				
	03-13-09	Z H	Y U	T H	Thomas Chow

D

Description: BNC Twist-On For RG 59,62
Part No: CPFIUG885
Application: For RG-59, RG-62 Cable
Crimp Tool: N/A
Impedance: 50 Ohms
Frequency Range: 0-4 GHz
Material: Body Brass Nickel plated
Contact Phosphor bronze Gold plated
Insulator Teflon
Nut Zinc Nickel plated
RoHS Compliance: Yes
Technical Detail: Refer to Emerson Document P/N 27-0000



C

B

A

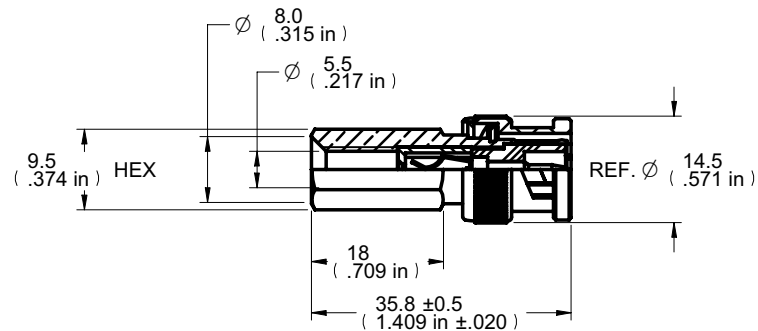
**DIM OUTLINE**

CUSTOMER COPY

TOLERANCE UNLESS OTHERWISE SPECIFIED		DRAWN BY GARY.ZHANG	DATE 03-13-09
DECIMALS	mm	CHECKED BY BETTY.YU	DATE 03-13-09
X	± 0.5	APPROVED BY THOMAS	DATE 03-13-09
X.X	± 0.3	U/M	mm
X.XX	± 0.1		
ANGLES	± 0.5°		

EMERSON
Network Power
Connectivity Solutions

TITLE
BNC TWIST-ON FOR RG59,62SHEET
1 OF 1DRAWING NO.
CPFIUG882-CUSTSIZE
A

5

4

3

2

1