



A. S. D.

## EMI filter and line termination for USB upstream ports

### Application

EMI Filter and line termination for USB upstream ports on:

- USB Hubs
- PC peripherals

### Features

- Monolithic device with recommended line termination for USB upstream ports
- Integrated  $R_t$  series termination and  $C_t$  bypassing capacitors.
- Integrated ESD protection
- Small package size

### Description

The USB specification requires upstream ports to be terminated with pull-up resistors from the D+ and D- lines to Vbus. On the implementation of USB systems, the radiated and conducted EMI should be kept within the required levels as stated by the FCC regulations. In addition to the requirements of termination and EMC compatibility, the computing devices are required to be tested for ESD susceptibility.

The USBUFxxW6 provides the recommended line termination while implementing a low pass filter to limit EMI levels and providing ESD protection which exceeds IEC 61000-4-2 level 4 standard. The device is packaged in a SOT323-6L which is the smallest available lead frame package (50% smaller than the standard SOT23).

### Benefits

- EMI / RFI noise suppression
- Required line termination for USB upstream ports
- ESD protection exceeding IEC 61000-4-2 level 4
- High flexibility in the design of high density boards
- Tailored to meet USB 1.1 standard

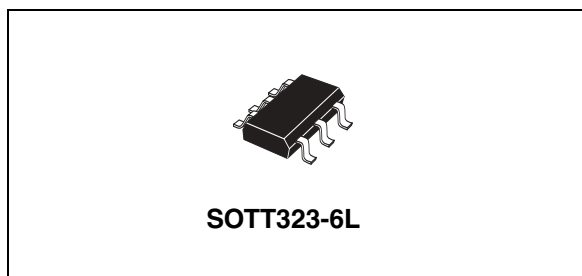

**Table 1. Order Codes**

Part Number	Marking
USBUF01W6	UU1
USBUF02W6	UU2

**Figure 1. Functional diagram**

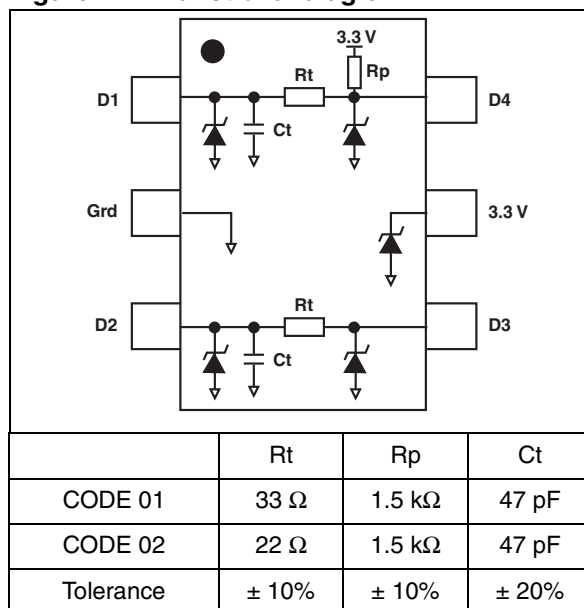

### Complies with the following standards:

**IEC 61000-4-2, level 4**  $\pm 15$  kV (air discharge)  
 $\pm 8$  kV (contact discharge)

### MIL STD 883E, Method 3015-7

Class 3 C = 100 pF R = 1500  $\Omega$

3 positive strikes and 3 negative strikes (F = 1 Hz)

# 1 Characteristics

**Table 2. Absolute ratings ( $T_{amb} = 25^{\circ} C$ )**

Symbol	Parameter	Value	Unit
$V_{PP}$	ESD discharge IEC 61000-4-2, air discharge	$\pm 16$	kV
	ESD discharge IEC 61000-4-2, contact discharge	$\pm 9$	
	ESD discharge - MIL STD 883E - Method 3015-7	$\pm 25$	
$T_j$	Maximum junction temperature	150	$^{\circ}C$
$T_{stg}$	Storage temperature range	- 55 to + 150	$^{\circ}C$
$T_L$	Lead solder temperature (10 second duration)	260	$^{\circ}C$
$T_{op}$	Operating temperature range	-40 to 70	$^{\circ}C$
P	Power rating per resistor	100	mW

# 2 Technical information

**Figure 2. USB standard requirements**

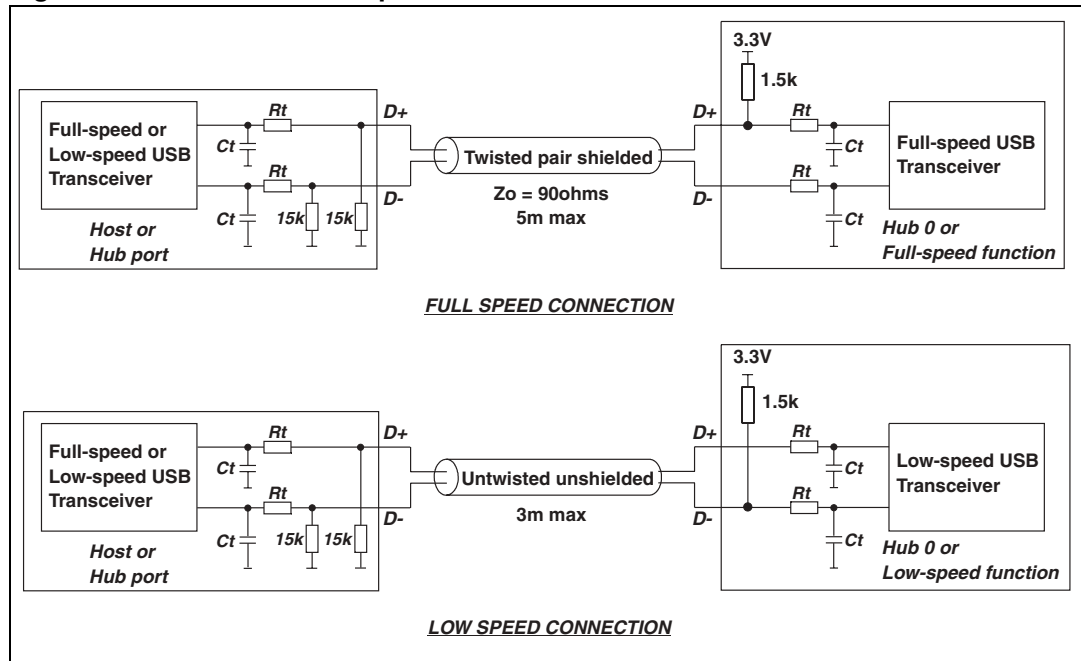

## 2.1 Application example

Figure 3. Implementation of ST solutions for USB ports

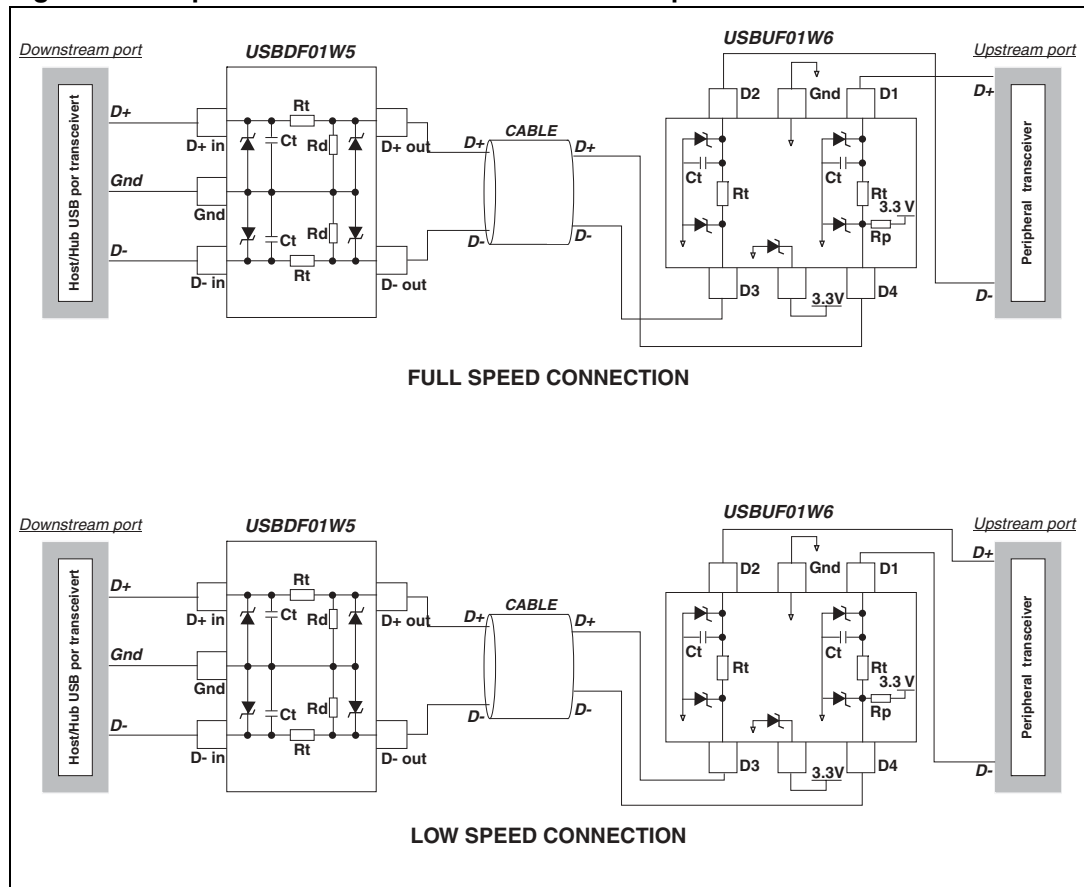

## 2.2 EMI filtering

Current FCC regulations requires that class B computing devices meet specified maximum levels for both radiated and conducted EMI.

- Radiated EMI covers the frequency range from 30 MHz to 1 GHz.
- Conducted EMI covers the 450 kHz to 30 MHz range.

For the types of devices utilizing the USB, the most difficult test to pass is usually the radiated EMI test. For this reason the USBUFxxW6 device is aiming to minimize radiated EMI.

The differential signal (D+ and D-) of the USB does not contribute significantly to radiated or conducted EMI because the magnetic field of both conductors cancels each other.

The inside of the PC environment is very noisy and designers must minimize noise coupling from the different sources. D+ and D- must not be routed near high speed lines (clocks spikes).

Induced common mode noise can be minimized by running pairs of USB signals parallel to each other and running grounded guard trace on each side of the signal pair from the USB controller to the USBUF device. If possible, locate the USBUF device physically near the

USB connectors. Distance between the USB controller and the USB connector must be minimized.

The 47 pF ( $C_t$ ) capacitors are used to bypass high frequency energy to ground and for edge control, and are placed between the driver chip and the series termination resistors ( $R_t$ ). Both  $C_t$  and  $R_t$  should be placed as close to the driver chip as is practicable.

The USBUFxxW6 ensures a filtering protection against ElectroMagnetic and RadioFrequency Interferences thanks to its low-pass filter structure. This filter is characterized by the following parameters:

- cut-off frequency
- Insertion loss
- high frequency rejection.

**Figure 4. USBUFxxW6 typical attenuation**

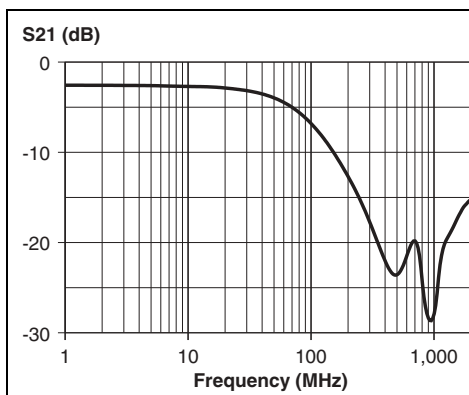

**Figure 5. Measurement configuration**

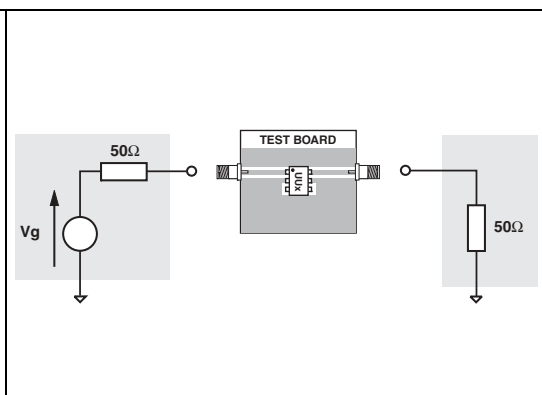

## 2.3 ESD PROTECTION

In addition to the requirements of termination and EMC compatibility, computing devices are required to be tested for ESD susceptibility. This test is described in the IEC 61000-4-2 and is already in place in Europe. This test requires that a device tolerates ESD events and remains operational without user intervention.

The USBUFxxW6 is particularly optimized to perform ESD protection. ESD protection is based on the use of device which clamps at:

$$V_{cl} = V_{BR} + R_d \cdot I_{PP}$$

This protection function is splitted in 2 stages. As shown in figure 6, the ESD strikes are clamped by the first stage S1 and then its remaining overvoltage is applied to the second stage through the resistor  $R_t$ . Such a configuration makes the output voltage very low at the output.

Figure 6. USBUFxxW6 ESD clamping behavior

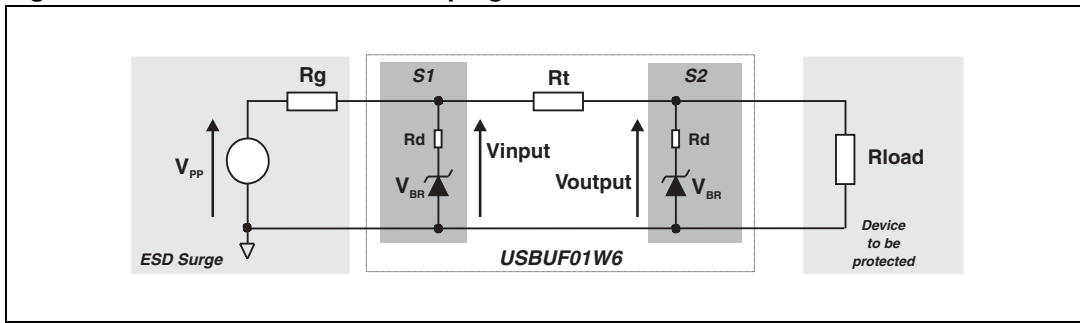
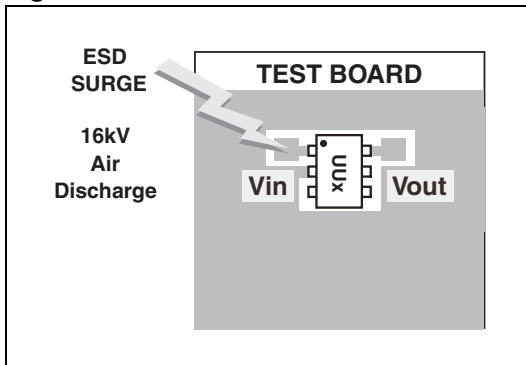

Figure 7. Measurement board



To have a good approximation of the remaining voltages at both Vin and Vout stages, we give the typical dynamical resistance value Rd. By taking into account these following hypothesis:  $R_t > R_d$ ,  $R_g > R_d$  and  $R_{load} > R_d$ , it gives these formulas:

$$V_{input} = \frac{R_g \cdot V_{BR} + R_d \cdot V_g}{R_g}$$

$$V_{output} = \frac{R_t \cdot V_{BR} + R_d \cdot V_{input}}{R_t}$$

The results of the calculation done for  $V_g = 8 \text{ kV}$ ,  $R_g = 330 \text{ } \Omega$  (IEC 61000-4-2 standard),  $V_{BR} = 7 \text{ V (typ.)}$  and  $R_d = 1 \text{ } \Omega$  (typ.) give:

$$V_{input} = 31.2 \text{ V}$$

$$V_{output} = 7.95 \text{ V}$$

This confirms the very low remaining voltage across the device to be protected. It is also important to note that in this approximation the parasitic inductance effect was not taken into account. This could be few tenths of volts during few ns at the  $V_{input}$  side. This parasitic effect is not present at the  $V_{output}$  side due the low current involved after the resistance  $R_t$ .

The measurements done hereafter show very clearly (figure 8) the high efficiency of the ESD protection:

- no influence of the parasitic inductances on Voutput stage
- Voutput clamping voltage very close to  $V_{BR}$  (breakdown voltage) in the positive way and  $-V_F$  (forward voltage) in the negative way

**Figure 8. Remaining voltage at both stages S1 (Vinput) and S2 (Voutput) during ESD surge**

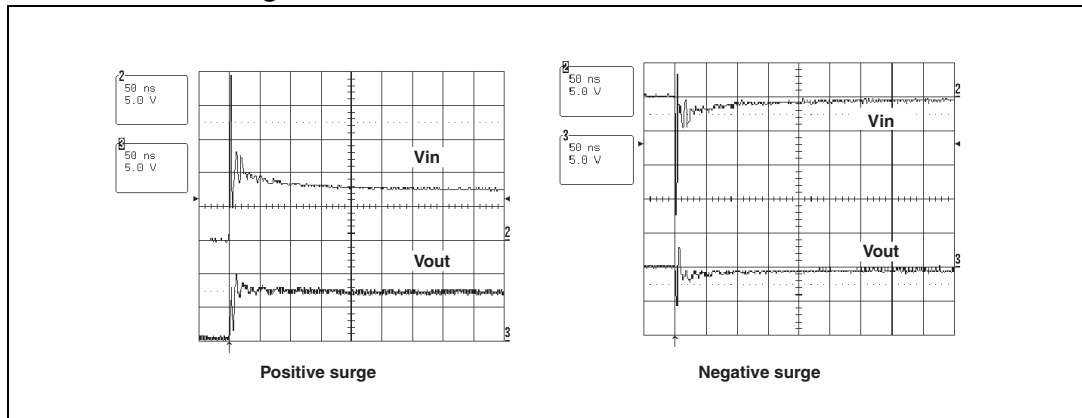

Please note that the USBUFxxW6 is not only acting for positive ESD surges but also for negative ones. For these kinds of disturbances it clamps close to ground voltage as shown in [Figure 8](#). (negative surge).

## 2.4 Latch-up phenomena

The early ageing and destruction of IC's is often due to latch-up phenomenon which is mainly induced by  $dV/dt$ . Thanks to its structure, the USBUFxxW6 provides a high immunity to latch-up phenomenon by smoothing very fast edges.

## 2.5 Crosstalk behavior

**Figure 9. Crosstalk phenomenon.**

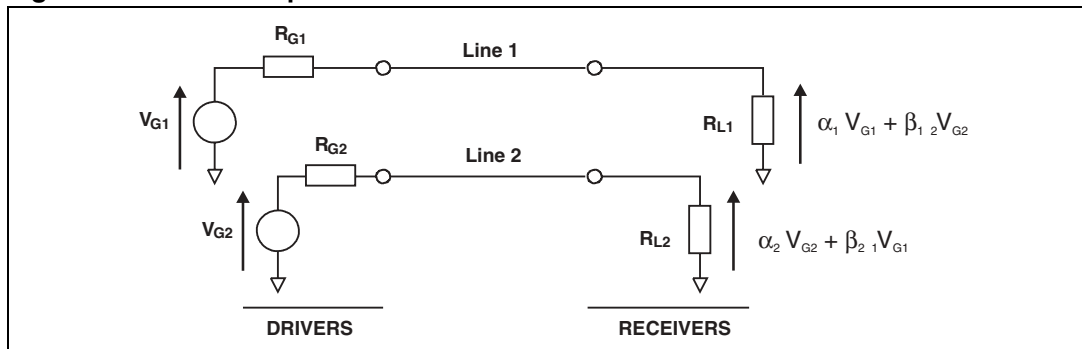

The crosstalk phenomenon is due to the coupling between 2 lines. The coupling factor ( $\beta_{12}$  or  $\beta_{21}$ ) increases when the gap across lines decreases, particularly in silicon dice. In the example above the expected signal on load  $R_{L2}$  is  $\alpha_2 V_{G2}$ , in fact the real voltage at this point has got an extra value  $\beta_{21} V_{G1}$ . This part of the  $V_{G1}$  signal represents the effect of the crosstalk phenomenon of the line 1 on the line 2. This phenomenon has to be taken into account when the drivers impose fast digital data or high frequency analog signals in the disturbing line. The perturbed line will be more affected if it works with low voltage signal or high load impedance (few  $k\Omega$ ).

**Figure 10. Figure 10: Analog crosstalk measurements**

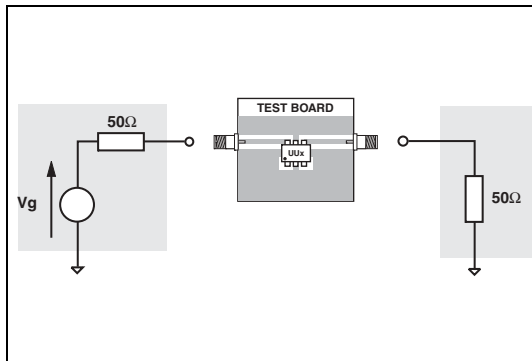

**Figure 11. Typical analog crosstalk results**

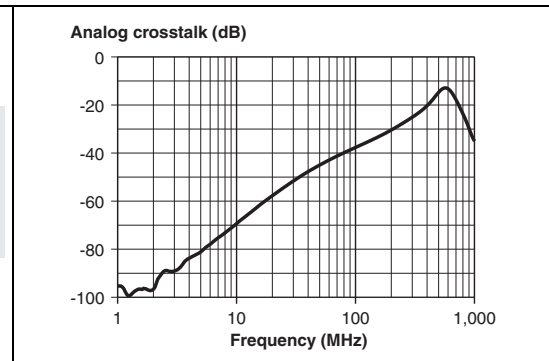

Figure 10. gives the measurement circuit for the analog crosstalk application. In Figure 11., the curve shows the effect of the D+ cell on the D-cell. In usual frequency range of analog signals (up to 100 MHz) the effect on disturbed line is less than -37 db.

**Figure 12. Digital crosstalk measurements configuration**

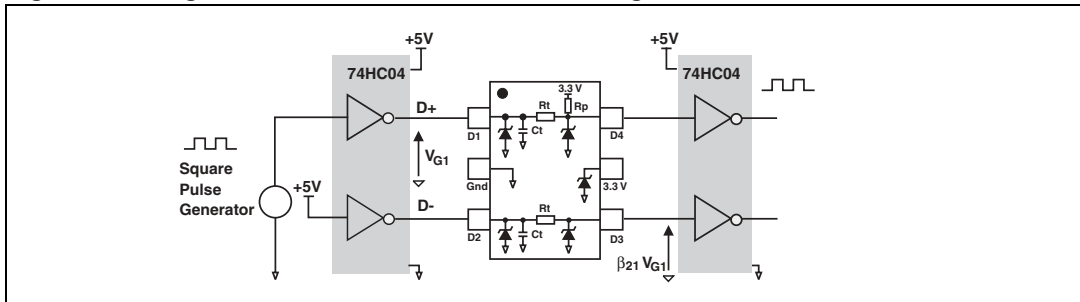

Figure 12. shows the measurement circuit used to quantify the crosstalk effect in a classical digital application.

**Figure 13. Digital crosstalk results**

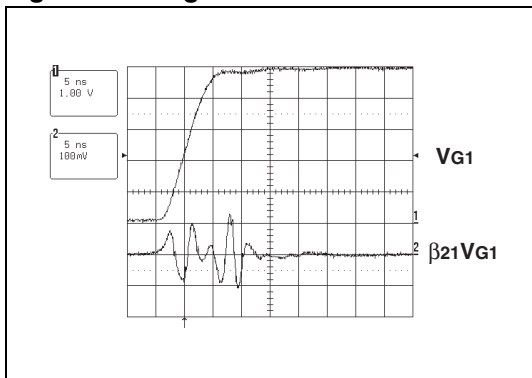

Figure 13. shows, with a signal from 0 to 5 V and rise time of few ns, the impact on the disturbed line is less than 250 mV peak to peak. No data disturbance was noted on the other line. The measurements performed with falling edges gives an impact within the same range.

## 2.6 Transition times

This low pass filter has been designed in order to meet the USB 1.1 standard requirements that implies the signal edges are maintained within the 4 -20 ns stipulated USB specification limits. To verify this point, we have measured the rise time of VD+ voltage with and without the USBUFxxW6 device.

**Figure 14. Typical rise and fall times: measurement configuration**

**Figure 15. Typical rise times with and without protection device**

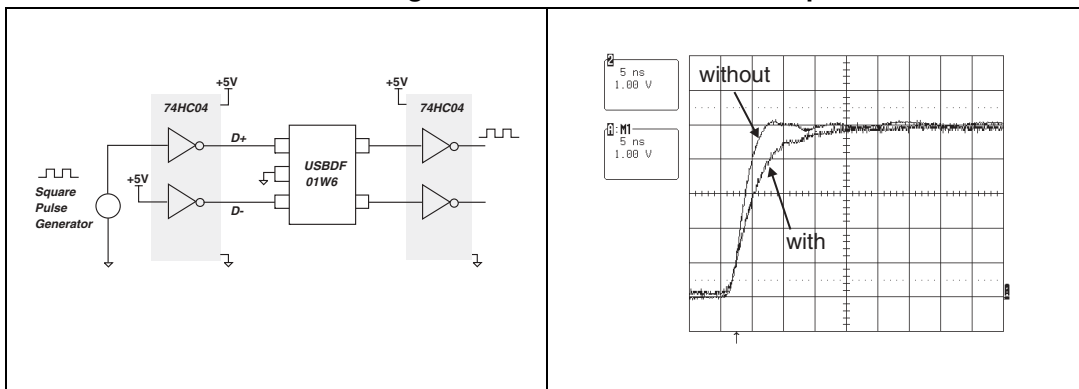

Figure 14. shows the circuit used to perform measurements of the transition times. In Figure 15., we see the results of such measurements:

- trise = 3.8 ns driver alone
- trise = 7.8 ns with protection device

The adding of the protection device causes the rise time increase of roughly 4ns.

Note: Rise time has been measured between 10% and 90% of the signal (resp. 90% and 10%)



### 3 Packaging information

**Table 3. SOT323-6L Package Mechanical Data**

REF.	DIMENSIONS			
	Millimeters		Inches	
	Min.	Max.	Min.	Max.
A	0.8	1.1	0.031	0.043
A1	0	0.1	0	0.004
A2	0.8	1	0.031	0.039
b	0.15	0.3	0.006	0.012
c	0.1	0.18	0.004	0.007
D	1.8	2.2	0.071	0.086
E	1.15	1.35	0.045	0.053
e	0.65 Typ.		0.025 Typ.	
HE	1.8	2.4	0.071	0.094
L	0.1	0.4	0.004	0.016
Q1	0.1	0.4	0.004	0.016

**Figure 16. Recommended footprint (dimensions in mm)**

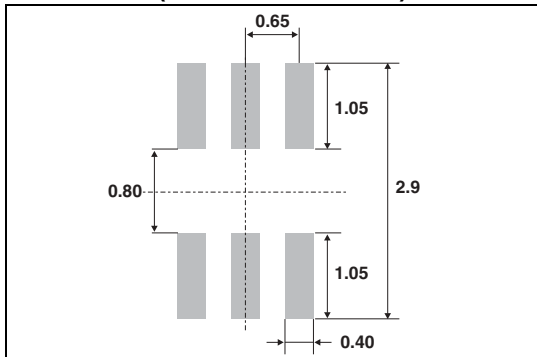

**Table 4. Mechanical specifications**

Lead plating	Tin-lead
Lead plating thickness	5 m min 25 m max
Lead material	Sn / Pb (70% to 90%Sn)
Lead coplanarity	10 m max
Body material	Molded epoxit
Flammability	UL94V-0

## 4 Ordering Information

Ordering code	Marking	Package	Weight	Base qty	Delivery mode
USBUF01W6	UU1	SOT323-6L	5.4 mg	3000	Tape & reel
USBUF02W6	UU2	SOT323-6L	5.4 mg	3000	Tape & reel

## 5 Revision History

Date	Revision	Description of Changes
Mar-2002	3A	Last update.
Feb-2005	4	Layout update. No content change.
28-Feb-2006	5	Operating temperature range updated to -40 to 70° C. Layout updated to current standard.

**Please Read Carefully:**

Information in this document is provided solely in connection with ST products. STMicroelectronics NV and its subsidiaries ("ST") reserve the right to make changes, corrections, modifications or improvements, to this document, and the products and services described herein at any time, without notice.

All ST products are sold pursuant to ST's terms and conditions of sale.

Purchasers are solely responsible for the choice, selection and use of the ST products and services described herein, and ST assumes no liability whatsoever relating to the choice, selection or use of the ST products and services described herein.

No license, express or implied, by estoppel or otherwise, to any intellectual property rights is granted under this document. If any part of this document refers to any third party products or services it shall not be deemed a license grant by ST for the use of such third party products or services, or any intellectual property contained therein or considered as a warranty covering the use in any manner whatsoever of such third party products or services or any intellectual property contained therein.

**UNLESS OTHERWISE SET FORTH IN ST'S TERMS AND CONDITIONS OF SALE ST DISCLAIMS ANY EXPRESS OR IMPLIED WARRANTY WITH RESPECT TO THE USE AND/OR SALE OF ST PRODUCTS INCLUDING WITHOUT LIMITATION IMPLIED WARRANTIES OF MERCHANTABILITY, FITNESS FOR A PARTICULAR PURPOSE (AND THEIR EQUIVALENTS UNDER THE LAWS OF ANY JURISDICTION), OR INFRINGEMENT OF ANY PATENT, COPYRIGHT OR OTHER INTELLECTUAL PROPERTY RIGHT.**

**UNLESS EXPRESSLY APPROVED IN WRITING BY AN AUTHORIZED REPRESENTATIVE OF ST, ST PRODUCTS ARE NOT DESIGNED, AUTHORIZED OR WARRANTED FOR USE IN MILITARY, AIR CRAFT, SPACE, LIFE SAVING, OR LIFE SUSTAINING APPLICATIONS, NOR IN PRODUCTS OR SYSTEMS, WHERE FAILURE OR MALFUNCTION MAY RESULT IN PERSONAL INJURY, DEATH, OR SEVERE PROPERTY OR ENVIRONMENTAL DAMAGE.**

Resale of ST products with provisions different from the statements and/or technical features set forth in this document shall immediately void any warranty granted by ST for the ST product or service described herein and shall not create or extend in any manner whatsoever, any liability of ST.

ST and the ST logo are trademarks or registered trademarks of ST in various countries.

Information in this document supersedes and replaces all information previously supplied.

The ST logo is a registered trademark of STMicroelectronics. All other names are the property of their respective owners.

© 2006 STMicroelectronics - All rights reserved

STMicroelectronics group of companies

Australia - Belgium - Brazil - Canada - China - Czech Republic - Finland - France - Germany - Hong Kong - India - Israel - Italy - Japan - Malaysia - Malta - Morocco - Singapore - Spain - Sweden - Switzerland - United Kingdom - United States of America

[www.st.com](http://www.st.com)

