

7-Channel Relay and Inductive Load Sink Driver

Check for Samples: [ULN2003LV](#)

FEATURES

- 7-Channel High Current Sink Drivers
- Supports up to 8V Output Pull-up Voltage
- Supports a Wide Range of 3V-to-5V Relay and Inductive Coils
- Low Output VOL of 0.4V (Typical) with
 - 100mA (Typical) Current Sink per Channel at 3.3V Logic Input⁽¹⁾
 - 140mA (Typical) Current Sink per Channel at 5.0V Logic Input⁽¹⁾
- Compatible to 3.3V and 5.0V Micro-controllers and Logic Interface
- Internal Free-wheeling Diodes for Inductive Kick-back Protection
- Input Pull-down Resistors Allows 3-stating the Input Driver
- Input RC-Snubber to Eliminate Spurious Operation in Noisy Environment
- Low Input and Output Leakage Currents
- Easy to use Parallel Interface
- ESD Protection Exceeds JESD 22
 - 2kV HBM, 500V CDM
- Available in 16-pin SOIC and TSSOP Packages

⁽¹⁾ Total current sink may be limited by the internal junction temperature, absolute maximum current levels etc - refer to the Electrical Specifications section for details.

APPLICATIONS

- Relay and Inductive Load Driver in Various Telecom, Consumer, and Industrial Applications
- Lamp and LED Displays
- Logic Level Shifter

Functional Diagram

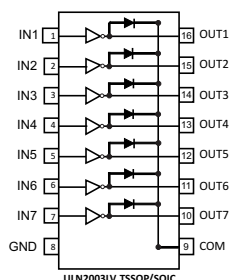

DESCRIPTION

The ULN2003LV is a low-voltage and low power upgrade of TI's popular ULN2003 family of 7-channel Darlington transistor array. The ULN2003LV sink driver features 7 low output impedance drivers to support low voltage relay and inductive coil applications. The low impedance drivers minimize on-chip power dissipation; up to 5 times lower for typical 3V relays. The ULN2003LV driver is pin-to-pin compatible with ULN2003 family of devices in similar packages.

The ULN2003LV supports 3.3V to 5V CMOS logic input interface thus making it compatible to a wide range of micro-controllers and other logic interfaces. The ULN2003LV features an improved input interface that minimizes the input DC current drawn from the external drivers. The ULN2003LV features an input RC snubber that greatly improves its performance in noisy operating conditions. The ULN2003LV channel inputs feature an internal input pull-down resistor thus allowing input logic to be tri-stated. The ULN2003LV may also support other logic input levels, e.g. TTL and 1.8V, refer to the Application Information section for details.

As shown in [Table 1](#), each output of the ULN2003LV features an internal free-wheeling diode connected in a common-cathode configuration at the COM pin.

The ULN2003LV provides flexibility of increasing current sink capability through combining several adjacent channels in parallel. Under typical conditions the ULN2003LV can support up to 1.0A of load current when all 7-channels are connected in parallel.

The ULN2003LV can also be used in a variety of other applications requiring a sink drivers. The ULN2003LV is available in 16-pin SOIC and 16-pin TSSOP packages.

Table 1. ULN2003LV Function Table⁽¹⁾

INPUT (IN1 – IN7)	OUTPUT (OUT1–OUT7)
L	H ⁺⁽²⁾
H	L
Z	H ⁺⁽²⁾

⁽¹⁾ L = Low-level (GND); H= High-level; Z= High-impedance;
⁽²⁾ H⁺ = Pull-up-level



Please be aware that an important notice concerning availability, standard warranty, and use in critical applications of Texas Instruments semiconductor products and disclaimers thereto appears at the end of this data sheet.



This integrated circuit can be damaged by ESD. Texas Instruments recommends that all integrated circuits be handled with appropriate precautions. Failure to observe proper handling and installation procedures can cause damage.

ESD damage can range from subtle performance degradation to complete device failure. Precision integrated circuits may be more susceptible to damage because very small parametric changes could cause the device not to meet its published specifications.

ORDERING INFORMATION⁽¹⁾

T _A	PART NUMBER	PACKAGE		TOP-SIDE MARKING
–40°C to 85°C	ULN2003LVDR	16-Pin SOIC	Reel of 2500	UN2003LV
	ULN2003LVPWR	16-Pin TSSOP	Reel of 2000	UN2003LV

(1) For the most current package and ordering information, see the Package Option Addendum at the end of this document, or see the TI website at www.ti.com.

ABSOLUTE MAXIMUM RATINGS⁽¹⁾

Specified at T_J = –40°C to 125°C unless otherwise noted.

		VALUE		UNIT
		MIN	MAX	
V _{IN}	Pins IN1- IN7 to GND voltage	–0.3	5.5	V
V _{OUT}	Pins OUT1 – OUT7 to GND voltage		8	V
V _{COM}	Pin COM to GND voltage		8	V
I _{GND}	Max GND-pin continuous current (T _J > +125°C)		700	mA
	Max GND-pin continuous current (T _J < +100°C)		1.0	A
P _D	Total device power dissipation at T _A = 85°C	16 Pin - SOIC	0.58	W
		16 Pin -TSSOP	0.45	W
ESD	ESD Rating – HBM		2	kV
	ESD Rating – CDM		500	V
T _A	Operating free-air ambient temperature range	–40	85	°C
T _J	Operating virtual junction temperature	–55	150	°C
T _{stg}	Storage temperature range	–55	150	°C

(1) Stresses beyond those listed under "Absolute Maximum Ratings" may cause permanent damage to the device. These are stress ratings only and functional operation of the device at these conditions is not implied. Exposure to absolute-maximum-rated conditions for extended periods may affect device reliability.

DISSIPATION RATINGS⁽¹⁾⁽²⁾

BOARD	PACKAGE	θ _{JC}	θ _{JA} ⁽³⁾	DERATING FACTOR ABOVE T _A = 25°C	T _A < 25°C	T _A = 70°C	T _A = 85°C
High-K	16-Pin SOIC	69°C/W	112°C/W	8.88 mW/°C	1.11 W	0.71 W	0.58 W
High-K	16-Pin TSSOP	74°C/W	142°C/W	7.11 mW/°C	0.88 W	0.56 W	0.45 W

(1) Maximum dissipation values for retaining device junction temperature of 150°C

(2) Refer to TI's design support web page at www.ti.com/thermal for improving device thermal performance

(3) Operating at the absolute T_{J,max} of 150°C can affect reliability– for higher reliability it is recommended to ensure T_J < 125°C

ELECTRICAL CHARACTERISTICS

Specified over the recommended junction temperature range $T_J = -40^{\circ}\text{C}$ to 125°C unless otherwise noted. Typical values are at $T_J = 25^{\circ}\text{C}$.

PARAMETER		TEST CONDITIONS	MIN	TYP	MAX	UNIT
INPUTS IN1 THROUGH IN7 PARAMETERS						
$V_{I(ON)}$	IN1–IN7 logic high input voltage	$V_{pull-up} = 3.3\text{ V}$, $R_{pull-up} = 1\text{ k}\Omega$, $I_{OUTX} = 3.2\text{ mA}$	1.65			V
$V_{I(OFF)}$	IN1–IN7 logic low input voltage	$V_{pull-up} = 3.3\text{ V}$, $R_{pull-up} = 1\text{ k}\Omega$, ($I_{OUTX} < 5\text{ }\mu\text{A}$)		0.4	0.6	
$I_{I(ON)}$	IN1–IN7 ON state input current	$V_{pull-up} = 3.3\text{ V}$, $V_{INx} = 3.3\text{ V}$		12	25	μA
$I_{I(OFF)}$	IN1–IN7 OFF state input leakage	$V_{pull-up} = 3.3\text{ V}$, $V_{INx} = 0\text{ V}$			250	nA
OUTPUTS OUT1 THROUGH OUT7 PARAMETERS						
$V_{OL(VCE-SAT)}$	OUT1–OUT7 low-level output voltage	$V_{INX} = 3.3\text{ V}$, $I_{OUTX} = 50\text{ mA}$		0.17	0.24	V
		$V_{INX} = 3.3\text{ V}$, $I_{OUTX} = 100\text{ mA}$		0.36	0.49	
		$V_{INX} = 5.0\text{ V}$, $I_{OUTX} = 100\text{ mA}$		0.26	0.42	
		$V_{INX} = 5.0\text{ V}$, $I_{OUTX} = 140\text{ mA}$		0.40		
$I_{OUT(ON)}$	OUT1–OUT7 ON-state continuous current ⁽¹⁾ (2) at $V_{OUTX} = 0.4\text{ V}$	$V_{INX} = 3.3\text{ V}$, $V_{OUTX} = 0.4\text{ V}$	80	100		mA
		$V_{INX} = 5.0\text{ V}$, $V_{OUTX} = 0.4\text{ V}$	95	140		
$I_{OUT(OFF)(ICEX)}$	OUT1–OUT7 OFF-state leakage current	$V_{INX} = 0\text{ V}$, $V_{OUTX} = V_{COM} = 8\text{ V}$		0.17		μA
SWITCHING PARAMETERS⁽³⁾⁽⁴⁾						
t_{PHL}	OUT1–OUT7 logic high propagation delay	$V_{INX} = 3.3\text{ V}$, $V_{pull-up} = 3.3\text{ V}$, $R_{pull-up} = 50\text{ }\Omega$		25		ns
		$V_{INX} = 5.0\text{ V}$, $V_{pull-up} = 5\text{ V}$, $R_{pull-up} = 1\text{ k}\Omega$		15		
t_{PLH}	OUT1–OUT7 logic low propagation delay	$V_{INX} = 3.3\text{ V}$, $V_{pull-up} = 3.3\text{ V}$, $R_{pull-up} = 50\text{ }\Omega$		45		ns
		$V_{INX} = 5.0\text{ V}$, $V_{pull-up} = 5\text{ V}$, $R_{pull-up} = 1\text{ k}\Omega$		80		
R_{PD}	IN1–IN7 input pull-down Resistance		210k	300k	390k	Ω
ζ	IN1–IN7 Input filter time constant			9		ns
C_{OUT}	OUT1–OUT7 output capacitance	$V_{INX} = 3.3\text{ V}$, $V_{OUTX} = 0.4\text{ V}$		15		pF
FREE-WHEELING DIODE PARAMETERS⁽⁵⁾⁽⁴⁾						
V_F	Forward voltage drop	$I_{F-peak} = 140\text{ mA}$, $V_F = V_{OUTx} - V_{COM}$		1.2		V
I_{F-peak}	Diode peak forward current			140		mA

- (1) The typical continuous current rating is limited by $V_{OL} = 0.4\text{ V}$. Whereas, absolute maximum operating continuous current may be limited by the Thermal Performance parameters listed in the Dissipation Rating Table and other Reliability parameters listed in the Recommended Operating Conditions Table.
- (2) Refer to the Absolute Maximum Ratings Table for T_J dependent absolute maximum GND-pin current.
- (3) Rise and Fall propagation delays, t_{PHL} and t_{PLH} , are measured between 50% values of the input and the corresponding output signal amplitude transition.
- (4) Guaranteed by design only.
- (5) Not rated for continuous current operation – for higher reliability use an external freewheeling diode for inductive loads resulting in more than specified maximum free-wheeling diode peak current across various temperature conditions

DEVICE INFORMATION

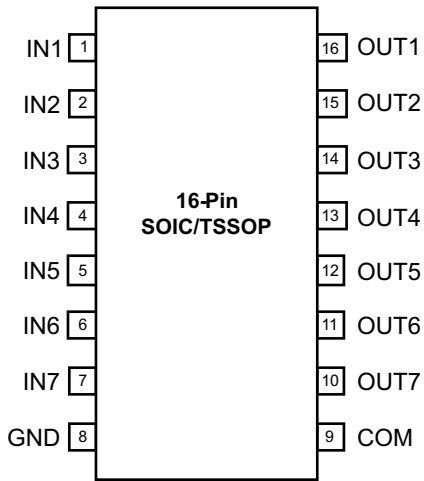

Figure 1. ULN2003LV PINOUT

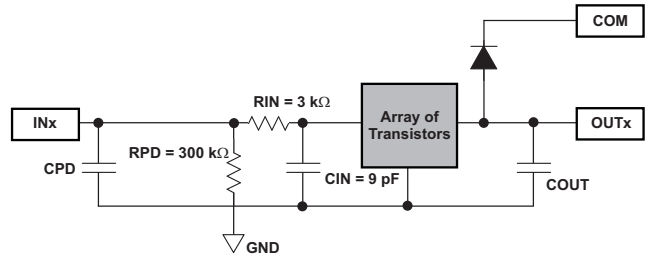

Figure 2. Channel Block Diagram

ULN2003LV PIN DESCRIPTION

NAME	PIN NUMBER		DESCRIPTION
	16-SOIC	16-TSSOP	
IN1 – IN7	1–7	1–7	Logic Input Pins IN1 through IN7
GND	8	8	Ground Reference Pin
COM	9	9	Internal Free-Wheeling Diode Common Cathode Pin
OUT7 – OUT1	10–16	10–16	Channel Output Pins OUT7 through OUT1

APPLICATION INFORMATION

TTL and other Logic Inputs

ULN2003LV input interface is specified for standard 3V and 5V CMOS logic interface. However, ULN2003LV input interface may support other logic input levels as well. Refer to [Figure 10](#) and [Figure 11](#) to establish VOL and the corresponding typical load current levels for various input voltage ranges. Application Information section shows an implementation to drive 1.8V relays using ULN2003LV.

Input RC Snubber

ULN2003LV features an input RC snubber that helps prevent spurious switching in noisy environment. Connect an external 1kΩ to 5kΩ resistor in series with the input to further enhance ULN2003LV's noise tolerance.

High-impedance Input Drivers

ULN2003LV features a 300kΩ input pull-down resistor. The presence of this resistor allows the input drivers to be tri-stated. When a high-impedance driver is connected to a channel input the ULN2003LV detects the channel input as a low level input and remains in the OFF position. The input RC snubber helps improve noise tolerance when input drivers are in the high-impedance state.

On-chip Power Dissipation

Use the below equation to calculate ULN2003LV on-chip power dissipation P_D :

$$P_D = \sum_{i=1}^N V_{OLi} \times I_{Li}$$

Where:

N is the number of channels active together.

V_{OLi} is the OUT_i pin voltage for the load current I_{Li} .

(1)

Thermal Reliability

It is recommended to limit ULN2003LV IC's die junction temperature to less than 125°C. The IC junction temperature is directly proportional to the on-chip power dissipation. Use the following equation to calculate the maximum allowable on-chip power dissipation for a target IC junction temperature:

$$PD_{(MAX)} = \frac{(T_{J(MAX)} - T_A)}{\theta_{JA}}$$

Where:

$T_{J(MAX)}$ is the target maximum junction temperature.

T_A is the operating ambient temperature.

θ_{JA} is the package junction to ambient thermal resistance.

(2)

Improving Package Thermal Performance

The package θ_{JA} value under standard conditions on a High-K board is listed in the [DISSIPATION RATINGS](#). θ_{JA} value depends on the PC board layout. An external heat sink and/or a cooling mechanism, like a cold air fan, can help reduce θ_{JA} and thus improve device thermal capabilities. Refer to TI's design support web page at www.ti.com/thermal for a general guidance on improving device thermal performance.

Application Examples

Inverting Logic Level Shifter

To use ULN2003LV as an open-collector or an open-drain inverting logic level shifter configure the device as shown in Figure 3. The ULN2003LV's each channel input and output logic levels can also be set independently. When using different channel input and output logic voltages connect the ULN2003LV COM pin to the maximum voltage.

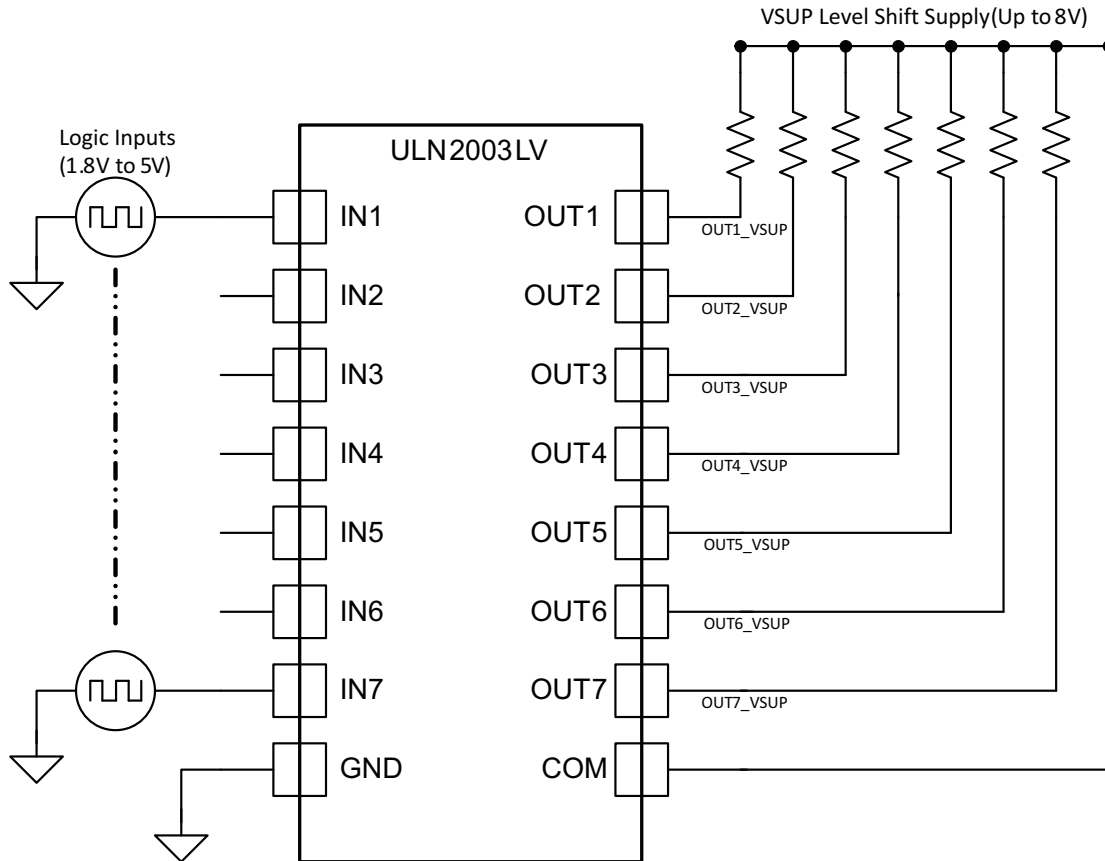

Figure 3. ULN2003LV as Inverting Logic Level Shifter

Max Supply Selector

The [Figure 4](#) implements a max supply selector along with a 4-channel logic level shifter using a single ULN2003LV. This setup configures ULN2003LV's channel clamp diodes OUT5 – OUT7 in a diode-OR configuration and thus the maximum supply among VSUP1, VSUP2 and VSUP3 becomes available at the COM pin. The maximum supply is then used as a pull-up voltage for level shifters. Limit the net GND pin current to less than 100mA DC to ensure reliability of the conducting diode. The unconnected inputs IN5-IN7 are pulled to GND potential through 300kΩ internal pull-down resistor.

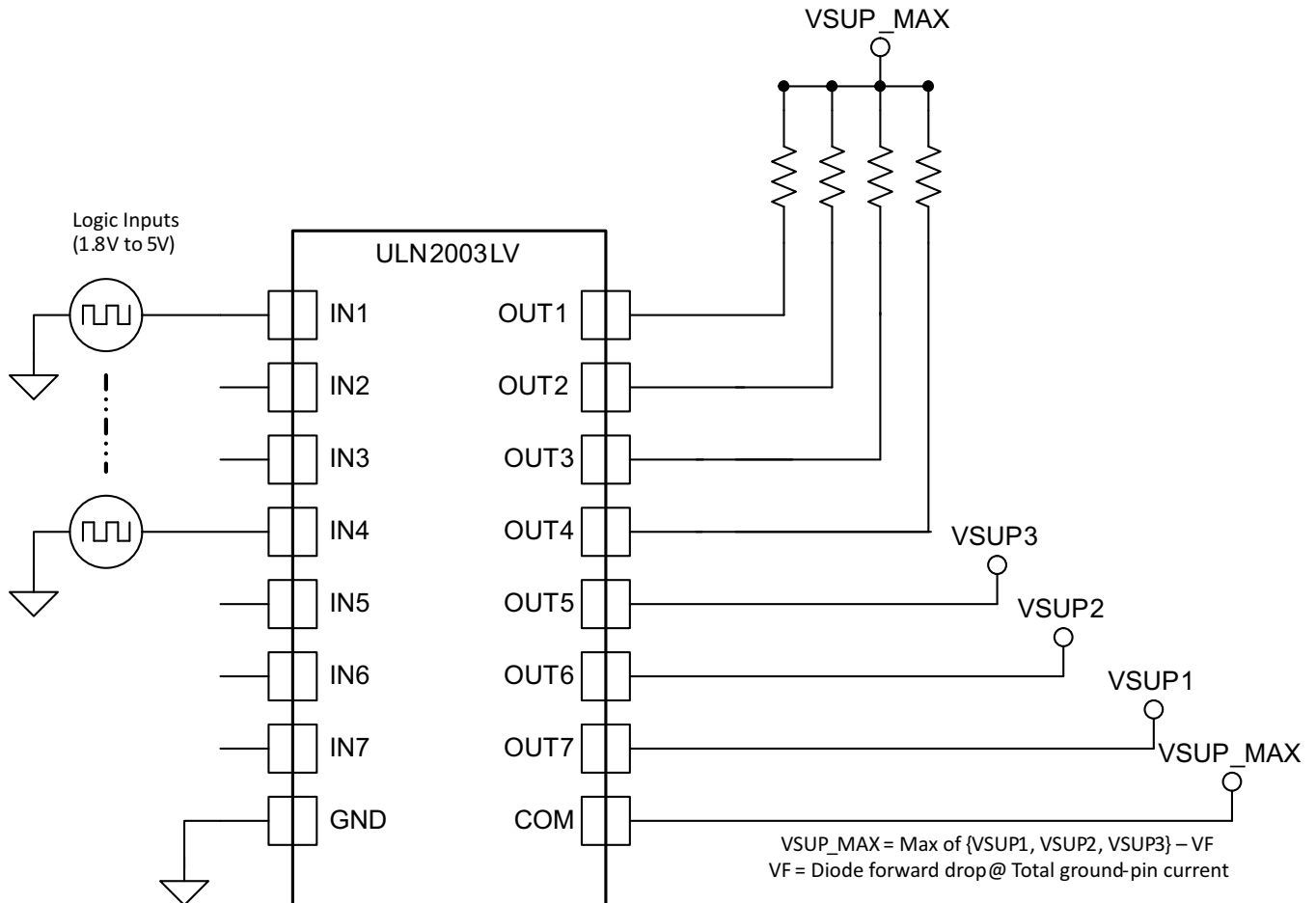

Figure 4. ULN2003LV as Max Supply Selector

Constant Current Generation

When configured as per [Figure 5](#) the ULN2003LV outputs OUT1-OUT6 act as independent constant current sources. The current flowing through the resistor R1 is copied on all other channels. To increase the current sourcing connect several output channels in parallel. To ensure best current copying set voltage drop across connected load such that VOUTx matches to VOUT7.

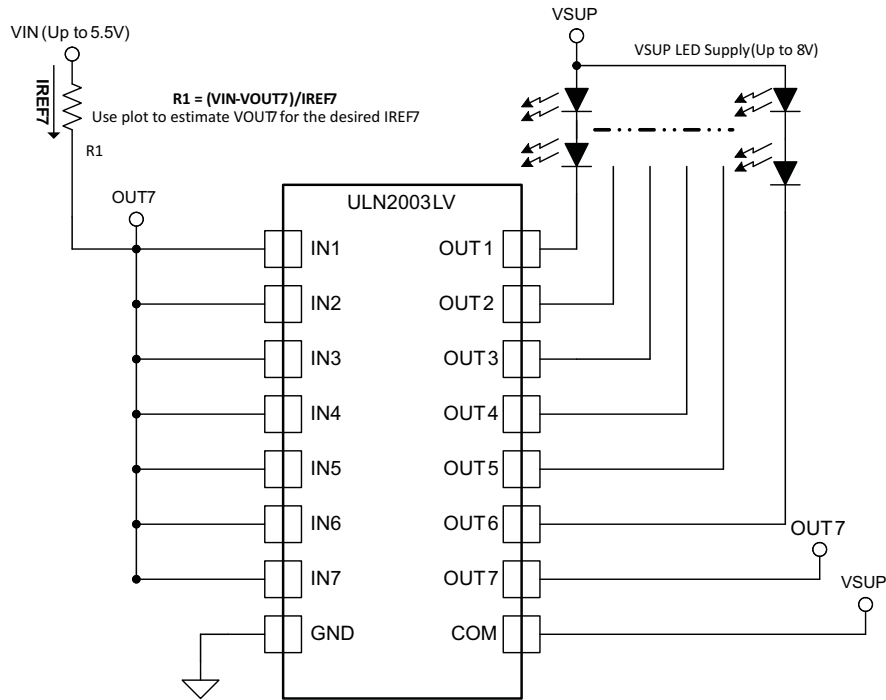

Figure 5. ULN2003LV as a Constant Current Driver

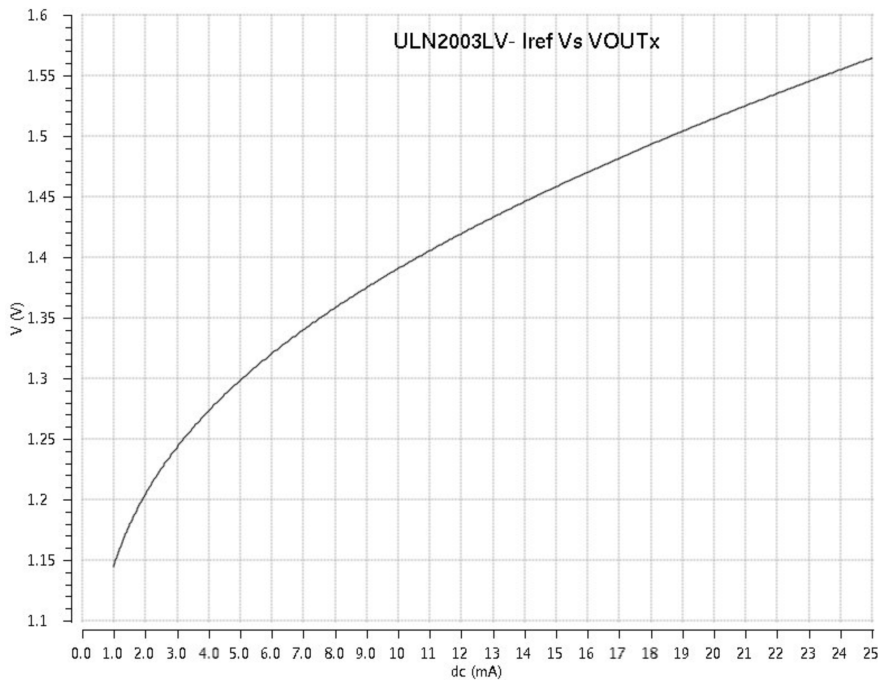

Figure 6. ULN2003LV Iref vs VOUTx

Unipolar Stepper Motor Driver

The [Figure 7](#) shows an implementation of ULN2003LV for driving a unipolar stepper motor. The unconnected input channels can be used for other functions. When an input pin is left open the internal 300kΩ pull down resistor pulls the respective input pin to GND potential. For higher noise immunity use an external short across an unconnected input and GND pins.

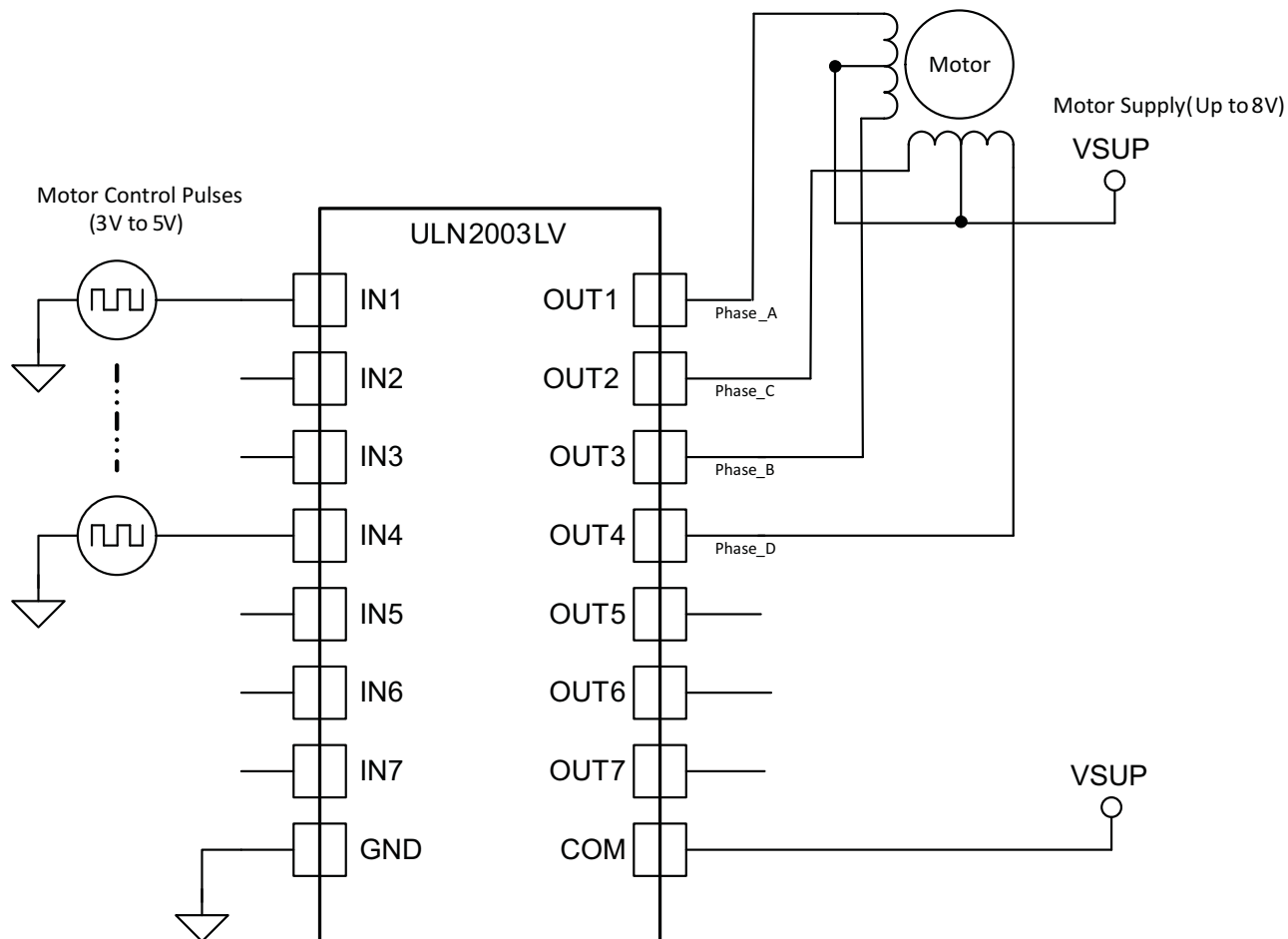

Figure 7. ULN2003LV as a Stepper Motor Driver

NOR Logic Driver

Figure 8 shows a NOR Logic driver implementation using ULN2003LV. The output channels sharing a common pull-up resistor implement a logic NOR of the respective channel inputs. The LEDs connected to outputs OUT5-OUT7 light up when any of the inputs IN5-IN7 is logic-high ($> V_{IH}$).

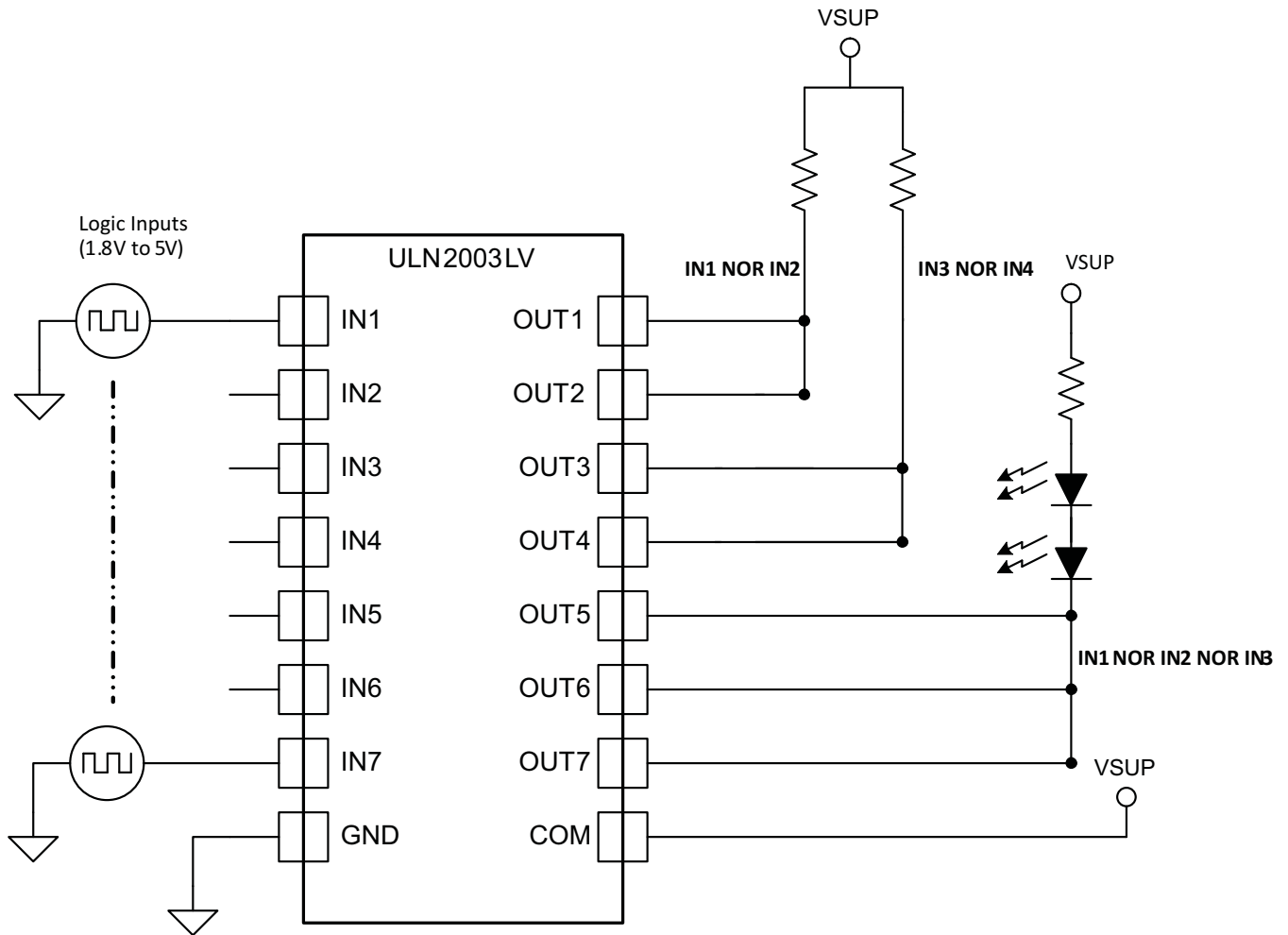

Figure 8. ULN2003LV as a NOR driver

1.8V Relay Driver

To drive lower voltage relays, like 1.8V, connect two or more adjacent channels in parallel as shown in [Figure 9](#). Connecting several channels in parallel lowers the channel output resistance and thus minimizes V_{OL} for a fixed current.

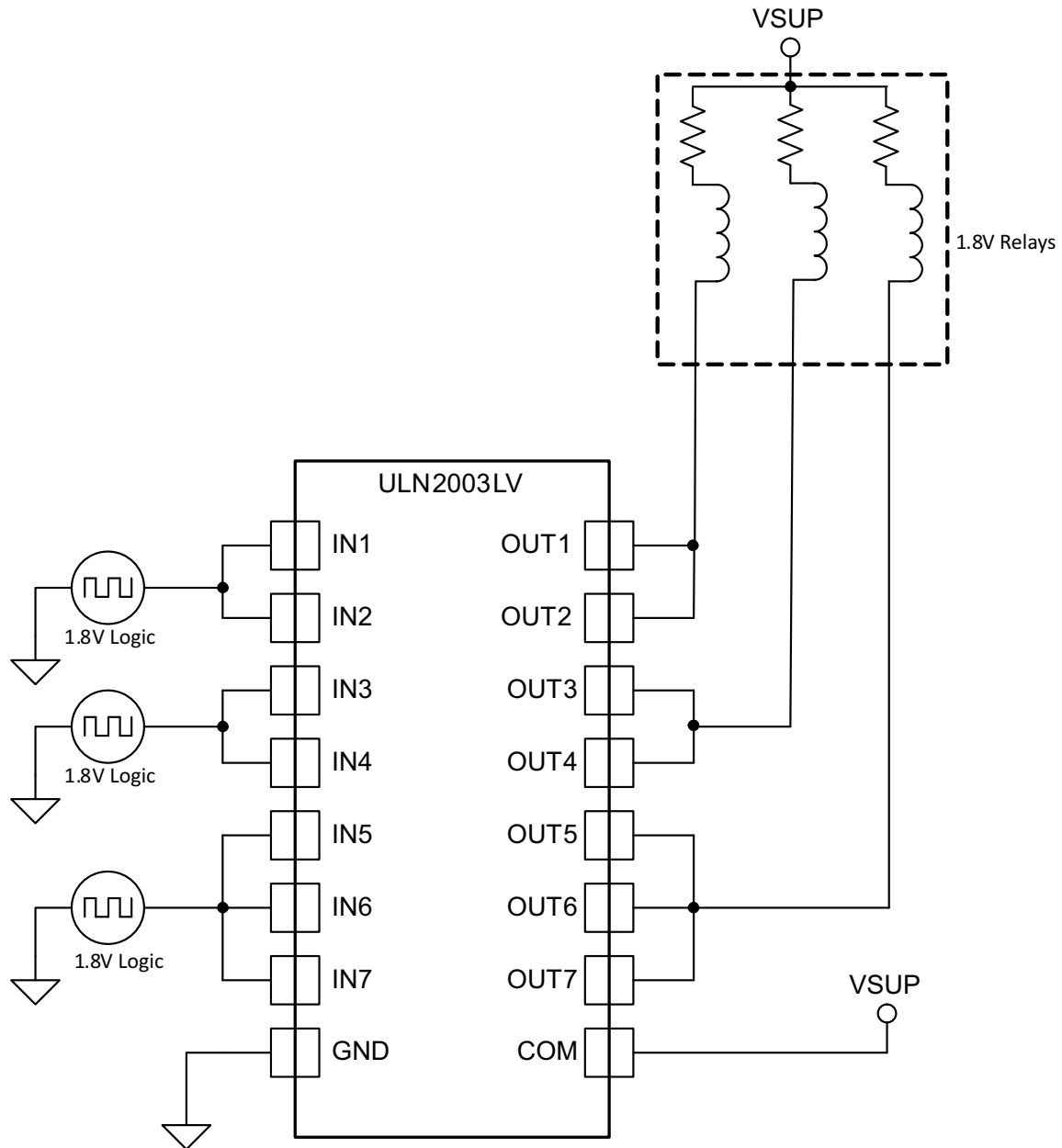

Figure 9. ULN2003LV Driving 1.8V Relays

TYPICAL CHARACTERISTICS

T_A = +25°C

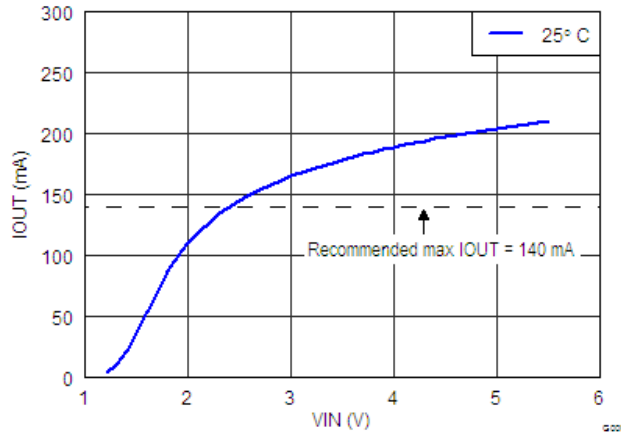

Figure 10. Load Current 1-Channel; VOL=0.4V

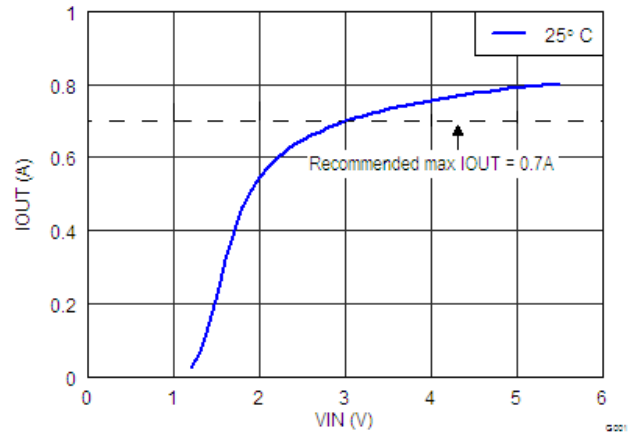

Figure 11. Load Current 7-Channels in parallel; VOL=0.4V

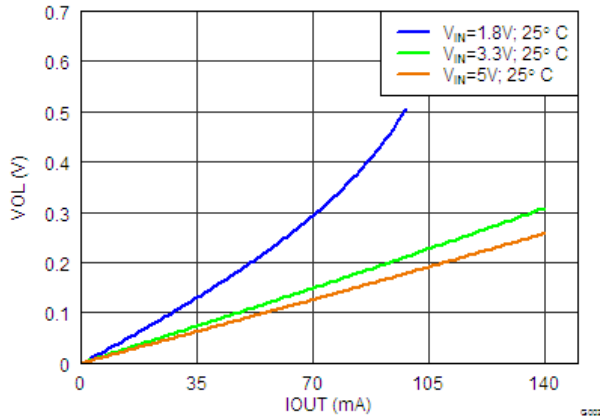

Figure 12. VOL versus IOUT VIN = 1.8V, 3.3V, 5.0V

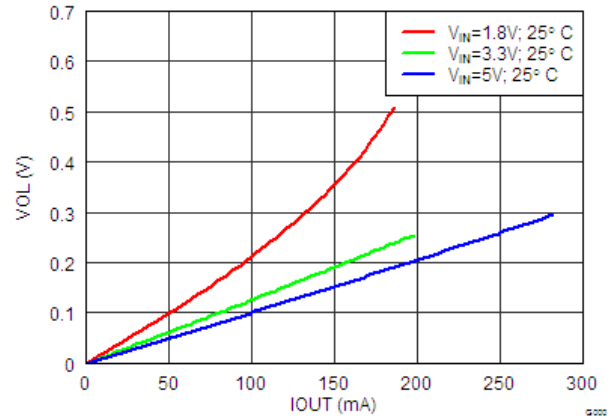

Figure 13. VOL versus IOUT 2-Channels in parallel; VOL=0.4V

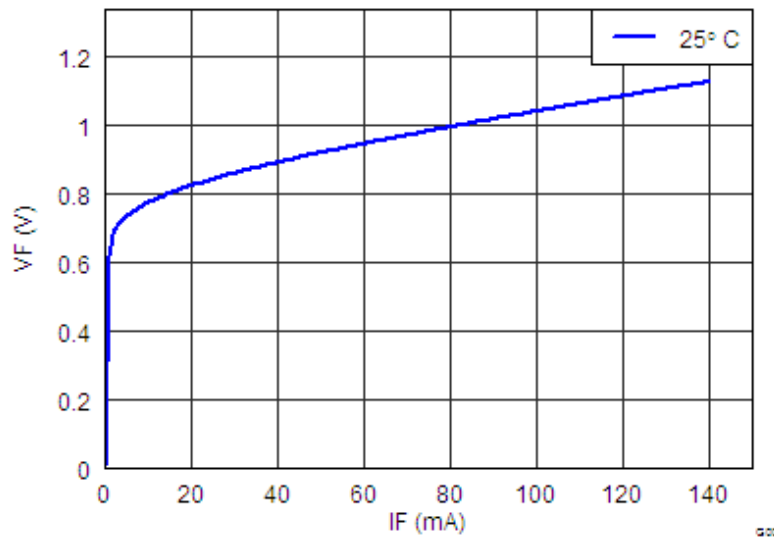

Figure 14. Freewheeling Diode VF versus IF

PACKAGING INFORMATION

Orderable Device	Status (1)	Package Type	Package Drawing	Pins	Package Qty	Eco Plan (2)	Lead/Ball Finish	MSL Peak Temp (3)	Op Temp (°C)	Top-Side Markings (4)	Samples
ULN2003LVDR	ACTIVE	SOIC	D	16	2500	Green (RoHS & no Sb/Br)	CU SN	Level-1-260C-UNLIM	-40 to 85	UN2003LV	Samples
ULN2003LVPWR	ACTIVE	TSSOP	PW	16	2000	Green (RoHS & no Sb/Br)	CU SN	Level-1-260C-UNLIM	-40 to 85	UN2003LV	Samples

(1) The marketing status values are defined as follows:

ACTIVE: Product device recommended for new designs.

LIFEBUY: TI has announced that the device will be discontinued, and a lifetime-buy period is in effect.

NRND: Not recommended for new designs. Device is in production to support existing customers, but TI does not recommend using this part in a new design.

PREVIEW: Device has been announced but is not in production. Samples may or may not be available.

OBSOLETE: TI has discontinued the production of the device.

(2) Eco Plan - The planned eco-friendly classification: Pb-Free (RoHS), Pb-Free (RoHS Exempt), or Green (RoHS & no Sb/Br) - please check <http://www.ti.com/productcontent> for the latest availability information and additional product content details.

TBD: The Pb-Free/Green conversion plan has not been defined.

Pb-Free (RoHS): TI's terms "Lead-Free" or "Pb-Free" mean semiconductor products that are compatible with the current RoHS requirements for all 6 substances, including the requirement that lead not exceed 0.1% by weight in homogeneous materials. Where designed to be soldered at high temperatures, TI Pb-Free products are suitable for use in specified lead-free processes.

Pb-Free (RoHS Exempt): This component has a RoHS exemption for either 1) lead-based flip-chip solder bumps used between the die and package, or 2) lead-based die adhesive used between the die and leadframe. The component is otherwise considered Pb-Free (RoHS compatible) as defined above.

Green (RoHS & no Sb/Br): TI defines "Green" to mean Pb-Free (RoHS compatible), and free of Bromine (Br) and Antimony (Sb) based flame retardants (Br or Sb do not exceed 0.1% by weight in homogeneous material)

(3) MSL, Peak Temp. -- The Moisture Sensitivity Level rating according to the JEDEC industry standard classifications, and peak solder temperature.

(4) Multiple Top-Side Markings will be inside parentheses. Only one Top-Side Marking contained in parentheses and separated by a "~" will appear on a device. If a line is indented then it is a continuation of the previous line and the two combined represent the entire Top-Side Marking for that device.

Important Information and Disclaimer: The information provided on this page represents TI's knowledge and belief as of the date that it is provided. TI bases its knowledge and belief on information provided by third parties, and makes no representation or warranty as to the accuracy of such information. Efforts are underway to better integrate information from third parties. TI has taken and continues to take reasonable steps to provide representative and accurate information but may not have conducted destructive testing or chemical analysis on incoming materials and chemicals. TI and TI suppliers consider certain information to be proprietary, and thus CAS numbers and other limited information may not be available for release.

In no event shall TI's liability arising out of such information exceed the total purchase price of the TI part(s) at issue in this document sold by TI to Customer on an annual basis.

TAPE AND REEL INFORMATION



QUADRANT ASSIGNMENTS FOR PIN 1 ORIENTATION IN TAPE



*All dimensions are nominal

Device	Package Type	Package Drawing	Pins	SPQ	Reel Diameter (mm)	Reel Width W1 (mm)	A0 (mm)	B0 (mm)	K0 (mm)	P1 (mm)	W (mm)	Pin1 Quadrant
ULN2003LVDR	SOIC	D	16	2500	330.0	16.8	6.5	10.3	2.1	8.0	16.0	Q1
ULN2003LVPWR	TSSOP	PW	16	2000	330.0	12.4	6.9	5.6	1.6	8.0	12.0	Q1

TAPE AND REEL BOX DIMENSIONS

*All dimensions are nominal

Device	Package Type	Package Drawing	Pins	SPQ	Length (mm)	Width (mm)	Height (mm)
ULN2003LVDR	SOIC	D	16	2500	364.0	364.0	27.0
ULN2003LVPWR	TSSOP	PW	16	2000	364.0	364.0	27.0

D (R-PDSO-G16)

PLASTIC SMALL OUTLINE



- NOTES:
- A. All linear dimensions are in inches (millimeters).
 - B. This drawing is subject to change without notice.
 - C. Body length does not include mold flash, protrusions, or gate burrs. Mold flash, protrusions, or gate burrs shall not exceed 0.006 (0,15) each side.
 - D. Body width does not include interlead flash. Interlead flash shall not exceed 0.017 (0,43) each side.
 - E. Reference JEDEC MS-012 variation AC.

PW (R-PDSO-G16)

PLASTIC SMALL OUTLINE

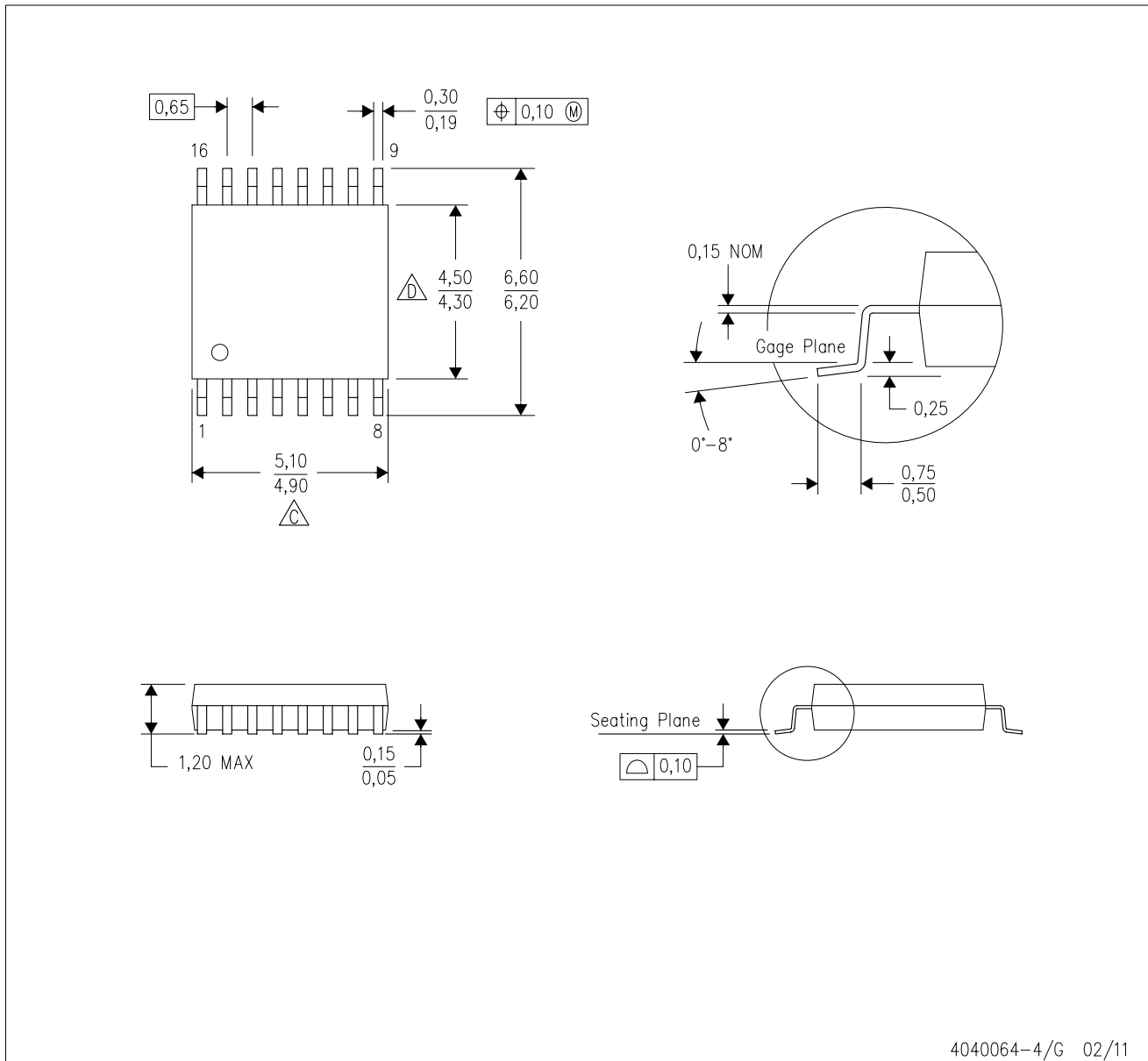

4040064-4/G 02/11

- NOTES:
- A. All linear dimensions are in millimeters. Dimensioning and tolerancing per ASME Y14.5M-1994.
 - B. This drawing is subject to change without notice.
 -  Body length does not include mold flash, protrusions, or gate burrs. Mold flash, protrusions, or gate burrs shall not exceed 0,15 each side.
 -  Body width does not include interlead flash. Interlead flash shall not exceed 0,25 each side.
 - E. Falls within JEDEC MO-153

PW (R-PDSO-G16)

PLASTIC SMALL OUTLINE



- NOTES:
- A. All linear dimensions are in millimeters.
 - B. This drawing is subject to change without notice.
 - C. Publication IPC-7351 is recommended for alternate designs.
 - D. Laser cutting apertures with trapezoidal walls and also rounding corners will offer better paste release. Customers should contact their board assembly site for stencil design recommendations. Refer to IPC-7525 for other stencil recommendations.
 - E. Customers should contact their board fabrication site for solder mask tolerances between and around signal pads.

IMPORTANT NOTICE

Texas Instruments Incorporated and its subsidiaries (TI) reserve the right to make corrections, enhancements, improvements and other changes to its semiconductor products and services per JESD46, latest issue, and to discontinue any product or service per JESD48, latest issue. Buyers should obtain the latest relevant information before placing orders and should verify that such information is current and complete. All semiconductor products (also referred to herein as "components") are sold subject to TI's terms and conditions of sale supplied at the time of order acknowledgment.

TI warrants performance of its components to the specifications applicable at the time of sale, in accordance with the warranty in TI's terms and conditions of sale of semiconductor products. Testing and other quality control techniques are used to the extent TI deems necessary to support this warranty. Except where mandated by applicable law, testing of all parameters of each component is not necessarily performed.

TI assumes no liability for applications assistance or the design of Buyers' products. Buyers are responsible for their products and applications using TI components. To minimize the risks associated with Buyers' products and applications, Buyers should provide adequate design and operating safeguards.

TI does not warrant or represent that any license, either express or implied, is granted under any patent right, copyright, mask work right, or other intellectual property right relating to any combination, machine, or process in which TI components or services are used. Information published by TI regarding third-party products or services does not constitute a license to use such products or services or a warranty or endorsement thereof. Use of such information may require a license from a third party under the patents or other intellectual property of the third party, or a license from TI under the patents or other intellectual property of TI.

Reproduction of significant portions of TI information in TI data books or data sheets is permissible only if reproduction is without alteration and is accompanied by all associated warranties, conditions, limitations, and notices. TI is not responsible or liable for such altered documentation. Information of third parties may be subject to additional restrictions.

Resale of TI components or services with statements different from or beyond the parameters stated by TI for that component or service voids all express and any implied warranties for the associated TI component or service and is an unfair and deceptive business practice. TI is not responsible or liable for any such statements.

Buyer acknowledges and agrees that it is solely responsible for compliance with all legal, regulatory and safety-related requirements concerning its products, and any use of TI components in its applications, notwithstanding any applications-related information or support that may be provided by TI. Buyer represents and agrees that it has all the necessary expertise to create and implement safeguards which anticipate dangerous consequences of failures, monitor failures and their consequences, lessen the likelihood of failures that might cause harm and take appropriate remedial actions. Buyer will fully indemnify TI and its representatives against any damages arising out of the use of any TI components in safety-critical applications.

In some cases, TI components may be promoted specifically to facilitate safety-related applications. With such components, TI's goal is to help enable customers to design and create their own end-product solutions that meet applicable functional safety standards and requirements. Nonetheless, such components are subject to these terms.

No TI components are authorized for use in FDA Class III (or similar life-critical medical equipment) unless authorized officers of the parties have executed a special agreement specifically governing such use.

Only those TI components which TI has specifically designated as military grade or "enhanced plastic" are designed and intended for use in military/aerospace applications or environments. Buyer acknowledges and agrees that any military or aerospace use of TI components which have **not** been so designated is solely at the Buyer's risk, and that Buyer is solely responsible for compliance with all legal and regulatory requirements in connection with such use.

TI has specifically designated certain components as meeting ISO/TS16949 requirements, mainly for automotive use. In any case of use of non-designated products, TI will not be responsible for any failure to meet ISO/TS16949.

Products

Audio	www.ti.com/audio
Amplifiers	amplifier.ti.com
Data Converters	dataconverter.ti.com
DLP® Products	www.dlp.com
DSP	dsp.ti.com
Clocks and Timers	www.ti.com/clocks
Interface	interface.ti.com
Logic	logic.ti.com
Power Mgmt	power.ti.com
Microcontrollers	microcontroller.ti.com
RFID	www.ti-rfid.com
OMAP Applications Processors	www.ti.com/omap
Wireless Connectivity	www.ti.com/wirelessconnectivity

Applications

Automotive and Transportation	www.ti.com/automotive
Communications and Telecom	www.ti.com/communications
Computers and Peripherals	www.ti.com/computers
Consumer Electronics	www.ti.com/consumer-apps
Energy and Lighting	www.ti.com/energy
Industrial	www.ti.com/industrial
Medical	www.ti.com/medical
Security	www.ti.com/security
Space, Avionics and Defense	www.ti.com/space-avionics-defense
Video and Imaging	www.ti.com/video

TI E2E Community

e2e.ti.com