



■ Features :

- AC input range selectable by switch
- Protections: Short circuit / Overload / Over voltage
- Forced air cooling by built-in DC fan
- PWM control and regulated
- Built-in cooling Fan ON-OFF control
- 100% full load burn-in test
- Fixed switching frequency at 25KHz
- Low cost
- 1 year warranty

SPECIFICATION

MODEL	S-350-5	S-350-7.5	S-350-12	S-350-13.5	S-350-15	S-350-24	S-350-27	S-350-36	S-350-48	
OUTPUT	DC VOLTAGE	5V	7.5V	12V	13.5V	15V	24V	27V	36V	48V
	RATED CURRENT	50A	40A	29A	25.8A	23.2A	14.6A	13A	9.7A	7.3A
	CURRENT RANGE	0 ~ 50A	0 ~ 40A	0 ~ 29A	0 ~ 25.8A	0 ~ 23.2A	0 ~ 14.6A	0 ~ 13A	0 ~ 9.7A	0 ~ 7.3A
	RATED POWER	250W	300W	348W	348.3W	348W	350.4W	351W	349.2W	350.4W
	RIPPLE & NOISE (max.) Note.2	150mVp-p	150mVp-p	150mVp-p	150mVp-p	150mVp-p	150mVp-p	200mVp-p	240mVp-p	240mVp-p
	VOLTAGE ADJ. RANGE	4.5 ~ 5.6V	6 ~ 9V	10 ~ 13.2V	12 ~ 15V	13.5 ~ 18V	20 ~ 26.4V	26 ~ 32V	32 ~ 40V	41 ~ 56V
	VOLTAGE TOLERANCE Note.3	±2.0%	±2.0%	±1.0%	±1.0%	±1.0%	±1.0%	±1.0%	±1.0%	±1.0%
	LINE REGULATION	±0.5%	±0.5%	±0.5%	±0.5%	±0.5%	±0.5%	±0.5%	±0.5%	±0.5%
	LOAD REGULATION	±1.0%	±1.0%	±0.5%	±0.5%	±0.5%	±0.5%	±0.5%	±0.5%	±0.5%
	SETUP, RISE TIME	200ms, 50ms at full load								
HOLD UP TIME (Typ.)	20ms at full load									
INPUT	VOLTAGE RANGE	90 ~ 132VAC / 180 ~ 264VAC by switch 254 ~ 370VDC								
	FREQUENCY RANGE	47 ~ 63Hz								
	EFFICIENCY (Typ.)	73%	76%	74%	79%	78%	81%	82%	83%	83%
	AC CURRENT (Typ.)	6.5A/115VAC		4A/230VAC						
	INRUSH CURRENT (Typ.)	50A/115VAC		50A/230VAC						
	LEAKAGE CURRENT	<3.5mA / 240VAC								
PROTECTION	OVERLOAD	105 ~ 135% rated output power Protection type : Constant current limiting, recovers automatically after fault condition is removed								
	OVER VOLTAGE	5.75 ~ 6.75V	9.4 ~ 10.9V	13.8 ~ 16.2V	15.5 ~ 18.2V	18 ~ 21V	27.6 ~ 32.4V	33.7 ~ 39.2V	40.5 ~ 46.5V	57.6 ~ 67.2V
FUNCTION	FAN ON/OFF CONTROL	RTH3 ≥ 55°C FAN ON, ≤ 45°C FAN OFF, ≥ 80°C output shutdown (5 ~ 7.5V)								
		RTH3 ≥ 65°C FAN ON, ≤ 55°C FAN OFF, ≥ 80°C output shutdown (12 ~ 15V)								
		RTH3 ≥ 70°C FAN ON, ≤ 60°C FAN OFF, ≥ 85°C output shutdown (24 ~ 48V)								
ENVIRONMENT	WORKING TEMP.	-10 ~ +60°C (Refer to output load derating curve)								
	WORKING HUMIDITY	20 ~ 90% RH non-condensing								
	STORAGE TEMP., HUMIDITY	-20 ~ +85°C, 10 ~ 95% RH								
	TEMP. COEFFICIENT	±0.03%/°C (0 ~ 50°C)								
SAFETY & EMC	WITHSTAND VOLTAGE	I/P-O/P:1.5KVAC I/P-FG:1.5KVAC O/P-FG:0.5KVAC								
	ISOLATION RESISTANCE	I/P-O/P, I/P-FG, O/P-FG:100M Ohms/500VDC								
OTHERS	MTBF	234.3K hrs min. MIL-HDBK-217F (25°C)								
	DIMENSION	215*115*50mm (L*W*H)								
	PACKING	1.07Kg; 12pcs/13.5Kg/0.92CUFT								
NOTE	1. All parameters NOT specially mentioned are measured at 230VAC input, rated load and 25°C of ambient temperature. 2. Ripple & noise are measured at 20MHz of bandwidth by using a 12" twisted pair-wire terminated with a 0.1uf & 47uf parallel capacitor. 3. Tolerance : includes set up tolerance, line regulation and load regulation.									

Mechanical Specification

Case No. 912C Unit:mm

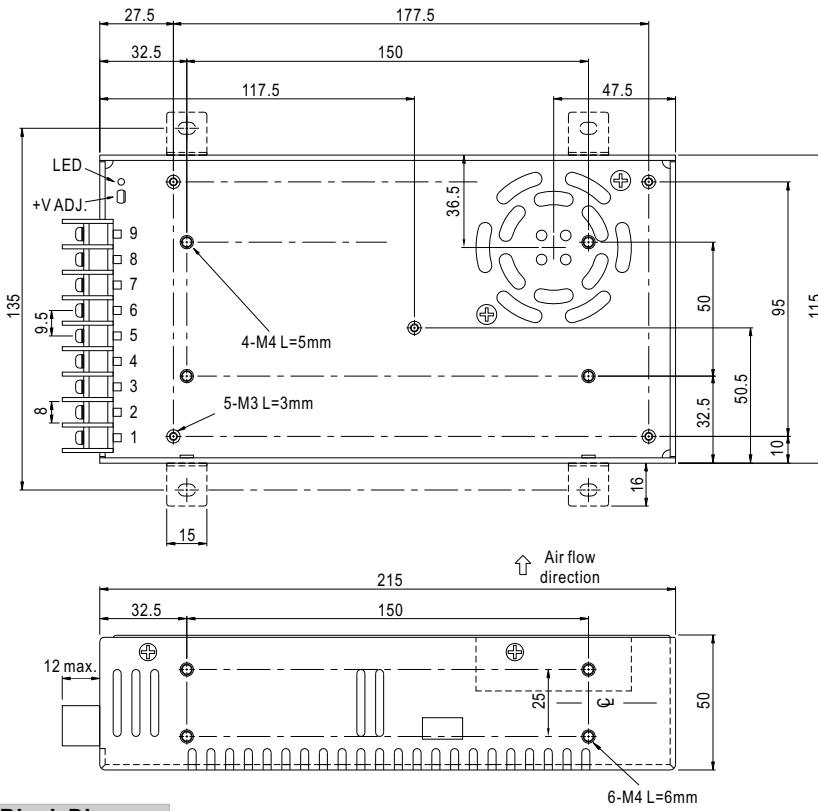

Terminal Pin No. Assignment

Pin No.	Assignment	Pin No.	Assignment
1	AC/L	4-6	DC OUTPUT -V
2	AC/N	7-9	DC OUTPUT +V
3	FG		

Block Diagram

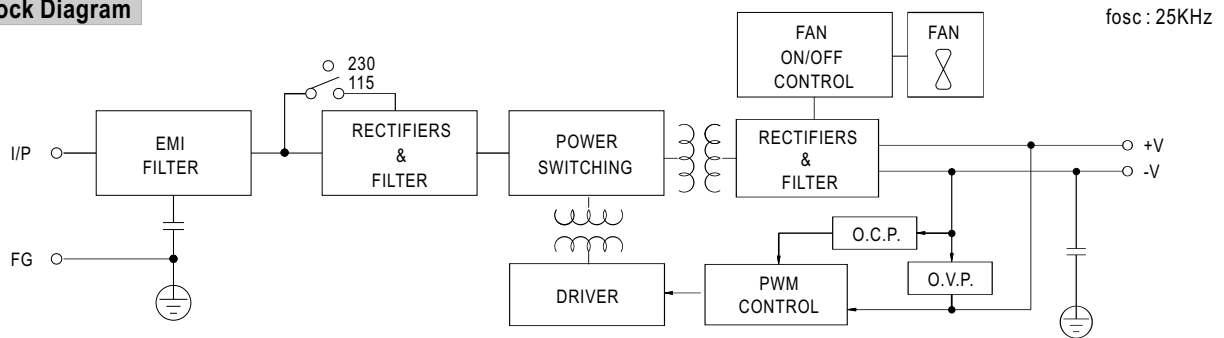

Derating Curve

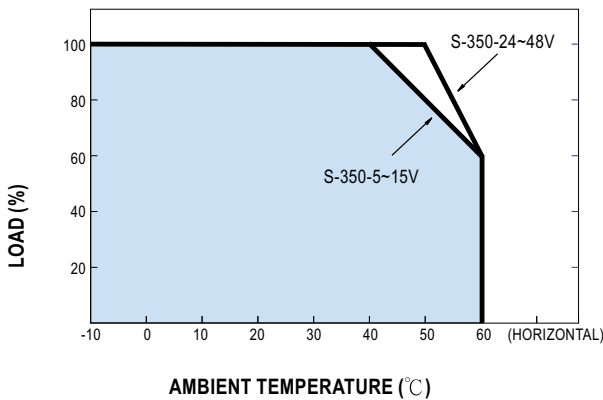

Static Characteristics (24V)

