

NOTE.
 1. 嵌合相手: 504051****
 MATE WITH: 504051****
 △ 偶数極の製品に適用
 APPLY EVEN CIRCUIT PRODUCTS.
 3. 材質
 MATERIAL
 ハウジング: 耐熱性樹脂 UL94-V0 BLACK
 HOUSING: HEATPROOF RESIN UL94-V0 BLACK
 ターミナル: 銅合金
 TERMINAL: COPPER ALLOY
 ネール: 銅合金
 NAIL: COPPER ALLOY
 4. メッキ
 PLATING
 ターミナル: 下地 ニッケルメッキ、コンタクト・半田付け部 金メッキ
 TERMINAL: UNDER NICKEL PLATING
 CONTACT AND TAIL GOLD PLATING
 ネール: 下地 ニッケルメッキ、鍍メッキ
 NAIL: UNDER NICKEL PLATING, TIN PLATING
 5. ELV及びRoHS適合品
 ELV AND RoHS COMPLIANT.

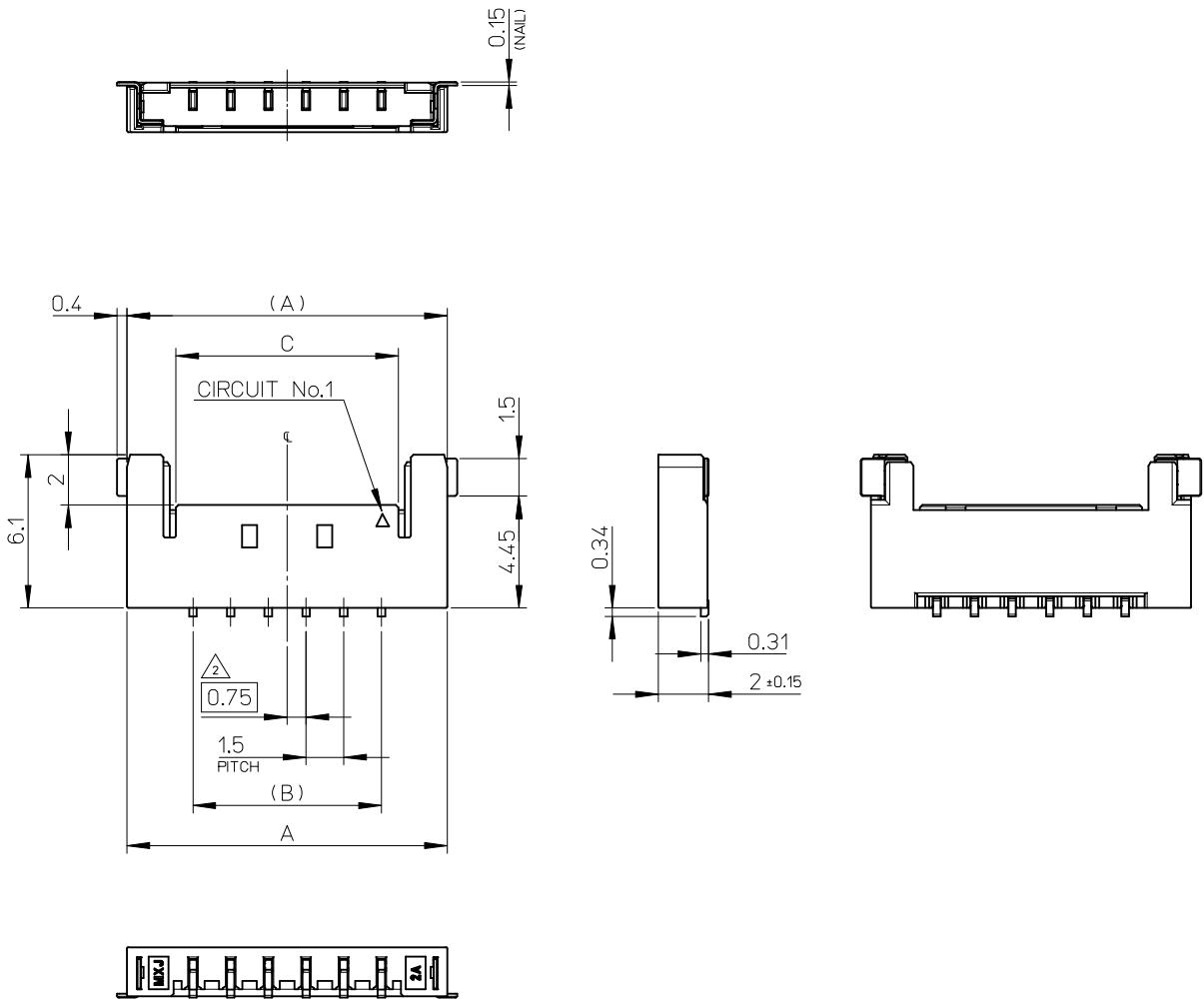

17.85	16.5	21.75	5040501291	12
14.85	13.5	18.75	5040501091	10
11.85	10.5	15.75	5040500891	8
10.35	9.0	14.25	5040500791	7
8.85	7.5	12.75	5040500691	6
5.85	4.5	9.75	5040500491	4
C	B	A	EMBOSSED PACKAGE	CIRCUIT
			ORDER No.	
CONNECTOR SERIES No. : 504050**91				

REVISED EC NO: J2014-1166 DRWN: YMAKE 2014/01/23 CHKD: KASAKAWA 2014/01/23 APPR: NUKITA 2014/03/03	DESCRIPTION	GENERAL TOLERANCES (UNLESS SPECIFIED)		DIMENSION STYLE MM ONLY		SCALE 5:1	DESIGN UNITS METRIC	THIRD ANGLE PROJECTION	
		10 UNDER	± 0.2	DRAWN BY THANYU	DATE 2012/03/29	TITLE 1.5 WIRE TO BOARD CONN. R/A H=2MM HEADER ASS'Y			
		10 OVER 30 UNDER	± 0.25	CHECKED BY KASAKAWA	DATE 2012/03/29				
		30 OVER	± 0.3	APPROVED BY Y01TO	DATE 2012/04/18				
REV		ANGULAR ±3 °	DRAFT WHERE APPLICABLE MUST REMAIN WITHIN DIMENSIONS	MATERIAL NO. SEE CHART	DOCUMENT NO. SD-504050-001	SHEET NO. 1 OF 2			

10 9 8 7 6 5 4 3 2 1

F

E

D

C

B

A

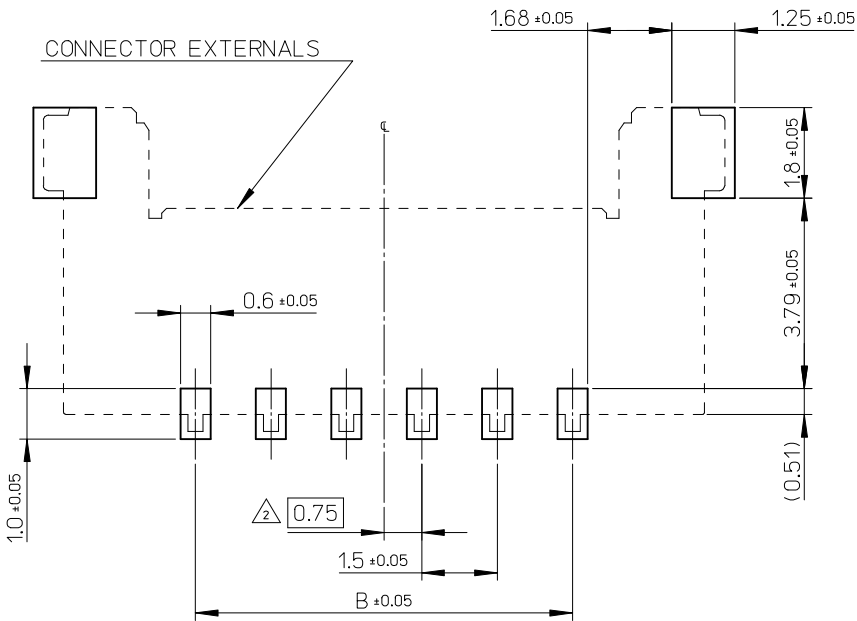

RECOMMENDED PATTERN LAYOUT (REF.)

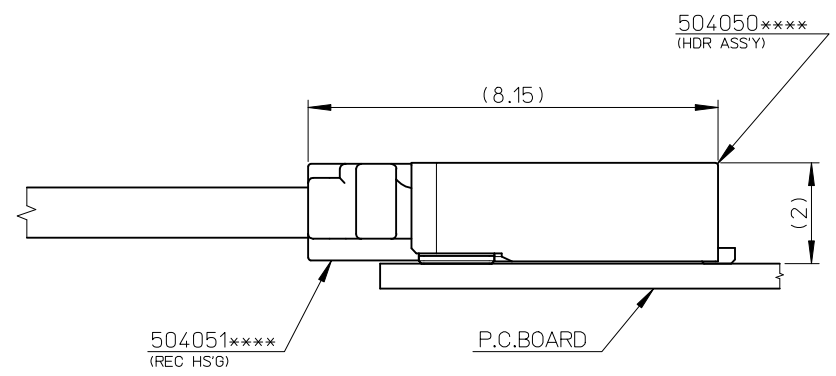

MATED CONNECTORS

REVISED EC NO: J2014-1166 DRWN: YMAKE 2014/01/23 CHKD: KASAKAWA 2014/01/23 APPR: NUKITA 2014/03/03	GENERAL TOLERANCES (UNLESS SPECIFIED)		DIMENSION STYLE MM ONLY	SCALE 10:1	DESIGN UNITS METRIC	THIRD ANGLE PROJECTION	
	10 UNDER	± 0.2	DRAWN BY THANYU	DATE 2012/03/29	TITLE 1.5 WIRE TO BOARD CONN. R/A H=2MM HEADER ASS'Y		
	10 OVER 30 UNDER	± 0.25	CHECKED BY KASAKAWA	DATE 2012/03/29	molex		
	30 OVER	± 0.3	APPROVED BY YOITO	DATE 2012/04/18	MATERIAL NO. SEE CHART	DOCUMENT NO. SD-504050-001	SHEET NO. 2 OF 2
ANGULAR ± 3 °	DRAFT WHERE APPLICABLE MUST REMAIN WITHIN DIMENSIONS		SIZE A3	THIS DRAWING CONTAINS INFORMATION THAT IS PROPRIETARY TO MOLEX INCORPORATED AND SHOULD NOT BE USED WITHOUT WRITTEN PERMISSION			

9 8 7 6 5 4 3 2

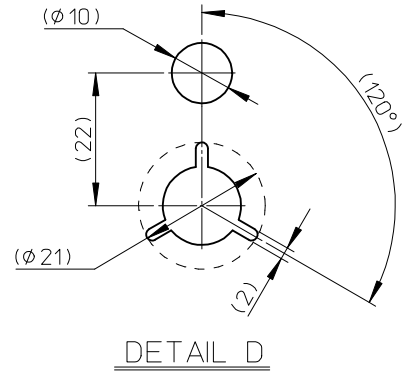
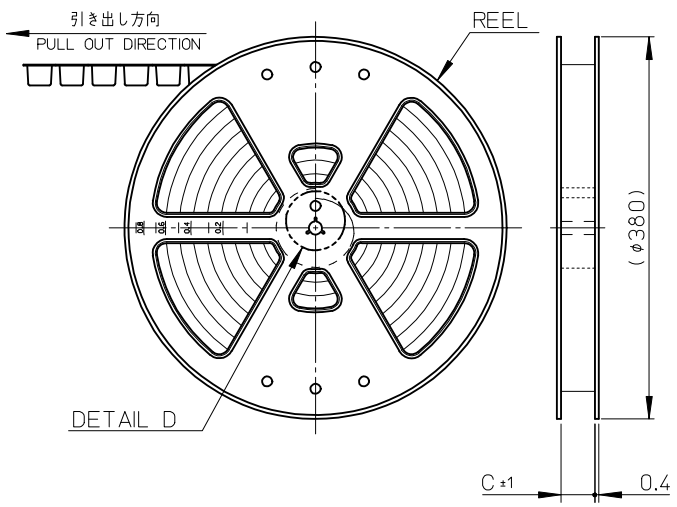
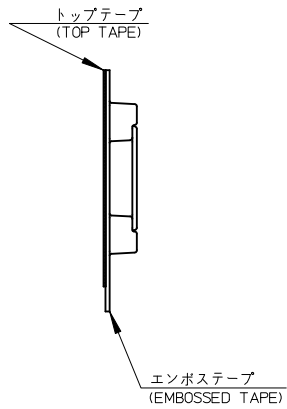
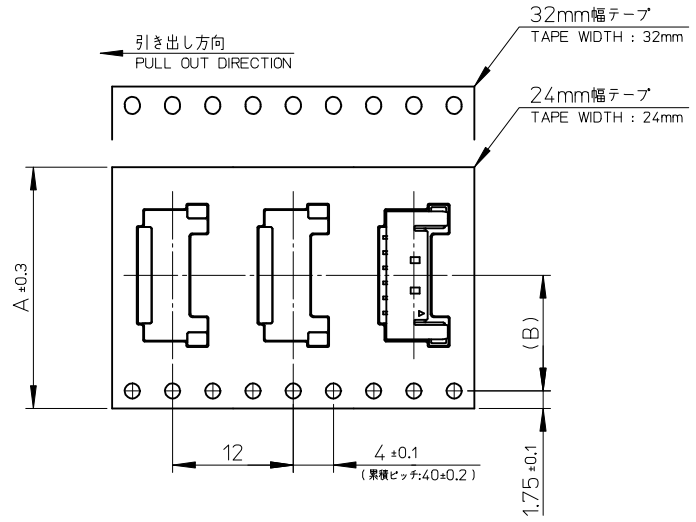

NOTE

1. 梱包数量: 2700個 /リール
NUMBER OF CONNECTORS : 2700 PIECES/REEL

2. リードテープ長さ
LEAD TAPE LENGTH

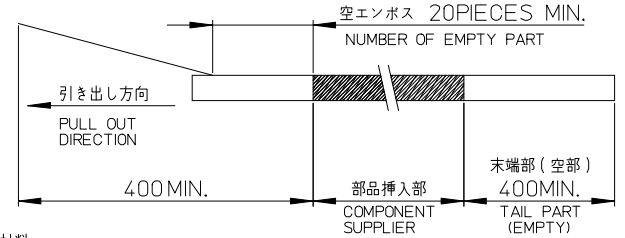

3. 材料

MATERIALS
 キャリアテープ : ポリスチレン
 CARRIER TAPE : POLYSTYRENE
 トップテープ : ポリエステル, ポリエチレン, ポリエチレンテレフタレート
 TOP TAPE : POLYESTER, POLYETHLENE, POLYETHYLENE TEREPHTHALATE
 リール : ポリスチレン (リサイクル材を含む)
 REEL : POLYSTYRENE (RECYCLE MATERIAL CONTAINED)

4. 製品詳細寸法については、RSD-504050-001を参照して下さい。
PLEASE REFER TO RSD-504050-001 FOR THE DETAILED DIMENSION OF THE CONNECTOR.

5. ELV及びRoHS適合品
ELV AND RoHS COMPLIANT.

6. トップテープの剥離強度については、IEC60286-3に準拠の事。
TOP TAPE PEEL FORCE IS DEFINED BY IEC60286-3.

45.5	20.2	44	5040501291	12
33.5	14.2	32	5040501091	10
33.5	14.2	32	5040500891	8
25.5	11.5	24	5040500791	7
25.5	11.5	24	5040500691	6
25.5	11.5	24	5040500491	4
C	B	A	ORDER No.	CIRCUIT
WIDTH OF TAPE				

REVISED EC NO: J2014-1166 DRWN:YMAKE CHKD:KASAKAWA APPR:NUKITA	DESCRIPTION 2014/01/23 2014/01/23 2014/03/03	GENERAL TOLERANCES (UNLESS SPECIFIED)		DIMENSION STYLE MM ONLY	SCALE 5:1	DESIGN UNITS METRIC	THIRD ANGLE PROJECTION	
		10 UNDER	±0.2	DRAWN BY THANYU	DATE 2012/03/29	TITLE EMBOSSED TAPE PACKAGE FOR 504050-**** (1.5 W/B CONN. H=2MM) molex		
		10 OVER 30 UNDER	±0.25	CHECKED BY KASAKAWA	DATE 2012/03/29			
		30 OVER	±0.3	APPROVED BY YOITO	DATE 2012/04/18			
ANGULAR ±3 °		MATERIAL NO. SEE CHART	DOCUMENT NO. SD-504050-002	SHEET NO. 1 OF 1				
DRAFT WHERE APPLICABLE MUST REMAIN WITHIN DIMENSIONS		SIZE A3	THIS DRAWING CONTAINS INFORMATION THAT IS PROPRIETARY TO MOLEX INCORPORATED AND SHOULD NOT BE USED WITHOUT WRITTEN PERMISSION					