

CTL Crimp Tool

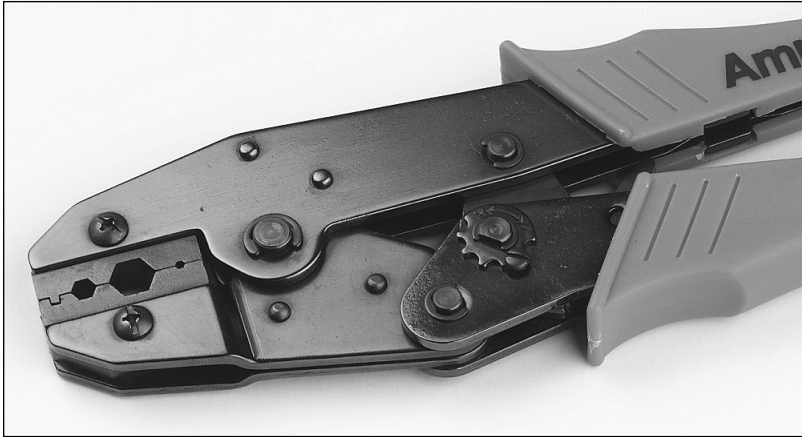

Amphenol CTL Series crimp tools are sold complete as a tool handle with the die set included. Purchase of some or all of the seven tools shown below will allow the user to terminate most popular RG coaxial cables.

To order the crimp tool required for a specific application, please refer to the Connector Assembly Instruction for the Amphenol part number. The recommended tool number is listed under the column labeled "CTL Series Tool Number".

CTL Crimp Tool order information

Crimp Tool Part Number	Cable RG-/U	Connector Series by Cavity Used	Hex Sizes Across Flats, In. (mm)		
			Cavity 1	Cavity 2	Cavity 3
CTL-13	RG-174, 178, 188, 196, 316, RD-316	MicroMate, SMB, SMA	.105 (2.67)	.128 (3.25)	.151 (3.84)
PCTL-1300 Die set only for Bench Crimper					

CAP Installation and Connector Removal Tool

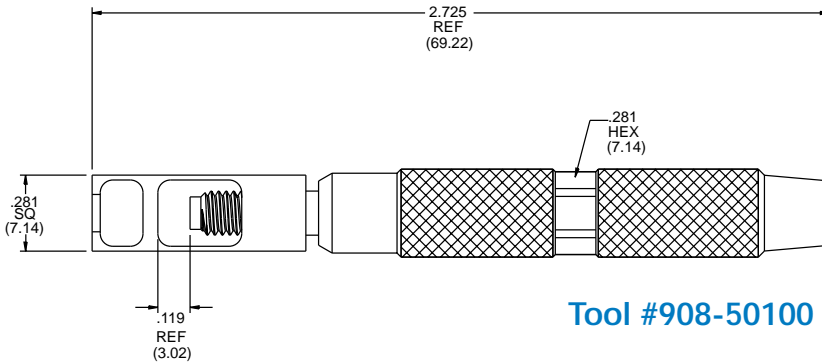

Universal tool for MicroMate (MMCX) right angle connectors for protective cap mounting and decoupling of connectors.

Tool Data

CTL Series Tool No.	Hex Sizes	Cable RG-/U	Connectors	Notes
CTL-14		Belden 8281, 1694A AT&T 734A		for 3-Piece BNC Crimp Connectors
CTL-15		AT&T 735A AT&T 734A Belden 8218		for 3-Piece BNC Crimp Connectors

▲ distributor stocked