



Technical Data Sheet

5mm Phototransistor T-1 3/4

PT331C

Features

- Fast response time
- High photo sensitivity
- Pb free
- The product itself will remain within RoHS compliant version.

Descriptions

- PT331C is a high speed and high sensitive silicon NPN epitaxial planar phototransistor in a standard 5 Φ package. Due to its water clear epoxy the device is sensitive to visible and near infrared radiation.



Applications

- Infrared applied system
- Floppy disk drive
- Optoelectronic switch

Device Selection Guide

| LED Part No. | Chip | Lens Color |
|--------------|----------|-------------|
| | Material | |
| PT | Silicon | Water Clear |

Package Dimensions

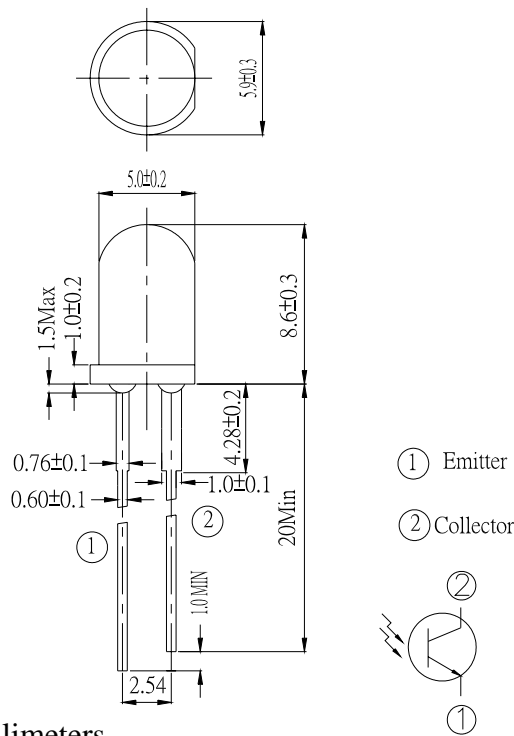

- Notes:** 1.All dimensions are in millimeters
 2.Tolerances unless dimensions $\pm 0.25\text{mm}$

Absolute Maximum Ratings (Ta=25°C)

| Parameter | Symbol | Rating | Units |
|--|-----------|-------------|-------|
| Collector-Emitter Voltage | V_{CEO} | 30 | V |
| Emitter-Collector-Voltage | V_{ECO} | 5 | V |
| Collector Current | I_C | 20 | mA |
| Operating Temperature | T_{opr} | -25 ~ +85°C | °C |
| Storage Temperature | T_{stg} | -40 ~ +85°C | °C |
| Lead Soldering Temperature | T_{sol} | 260 | °C |
| Power Dissipation at (or below) 25°C Free Air Temperature | P_c | 75 | mW |

Notes: *1:Soldering time ≤ 5 seconds.

Electro-Optical Characteristics (Ta=25°C)

| Parameter | Symbol | Condition | Min. | Typ. | Max. | Units |
|---------------------------------------|-----------------|--|------|----------|------|---------|
| Collector – Emitter Breakdown Voltage | BV_{CEO} | $I_C=100\ \mu A$ $E_e=0mW/cm^2$ | 30 | --- | --- | V |
| Emitter-Collector Breakdown Voltage | BV_{ECO} | $I_E=100\ \mu A$ $E_e=0mW/cm^2$ | 5 | --- | --- | V |
| Collector-Emitter Saturation Voltage | $V_{CE(sat)}$ | $I_C=2mA$ $E_e=1mW/cm^2$ | --- | --- | 0.4 | V |
| Rise Time | t_r | $V_{CE}=5V$ $I_C=mA$ $RL=1000\ \Omega$ | --- | 15 | --- | μS |
| Fall Time | t_f | | --- | 15 | --- | |
| Collector Dark Current | I_{CEO} | $E_e=0mW/cm^2$ $V_{CE}=20V$ | --- | --- | 100 | nA |
| On State Collector Current | $I_{C(on)}$ | $E_e=1mW/cm^2$ $V_{CE}=5V$ | 0.7 | 2.5 | --- | mA |
| Wavelength of Peak Sensitivity | λ_p | --- | --- | 940 | --- | nm |
| Rang of Spectral Bandwidth | $\lambda_{0.5}$ | --- | --- | 400-1100 | --- | nm |

Rankings

| Parameter | Symbol | Min | Max | Unit | Test Condition |
|-----------|-------------|------|------|------|---------------------------------|
| G | $I_{C(ON)}$ | 0.70 | 1.90 | mA | $V_{CE}=5V$ $E_e=1mW/c\ m^2$ |
| H | | 1.14 | 2.60 | | |
| J | | 1.77 | 3.61 | | |
| K | | 2.67 | 5.07 | | |
| L | | 4.18 | 7.07 | | |

Typical Electro-Optical Characteristics Curves

Fig.1 Collector Power Dissipation vs. Ambient Temperature

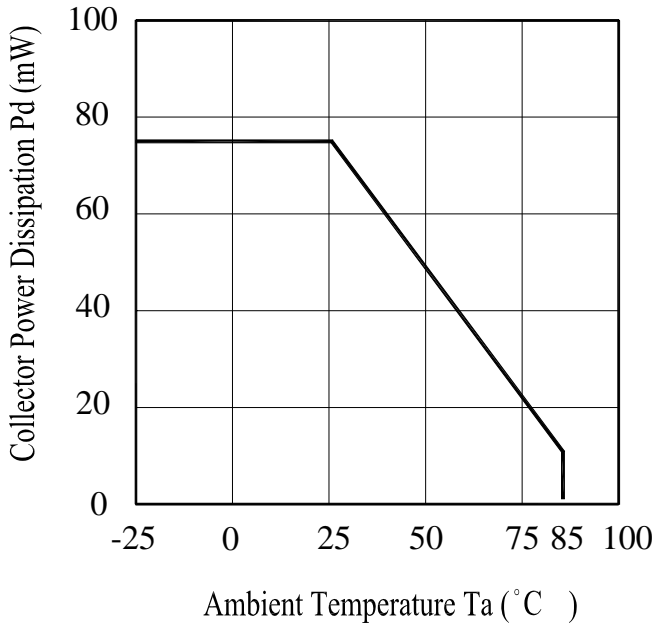

Fig.2 Spectral Sensitivity

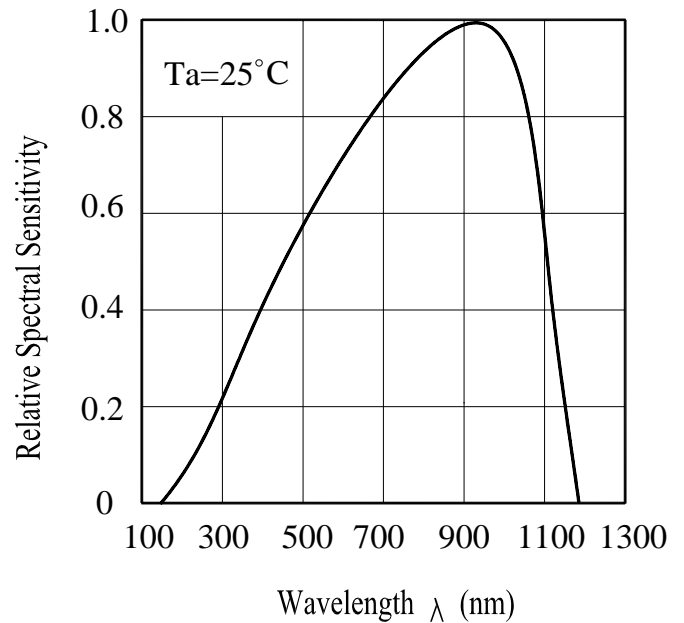

Fig.3 Relative Collector Current vs. Ambient Temperature

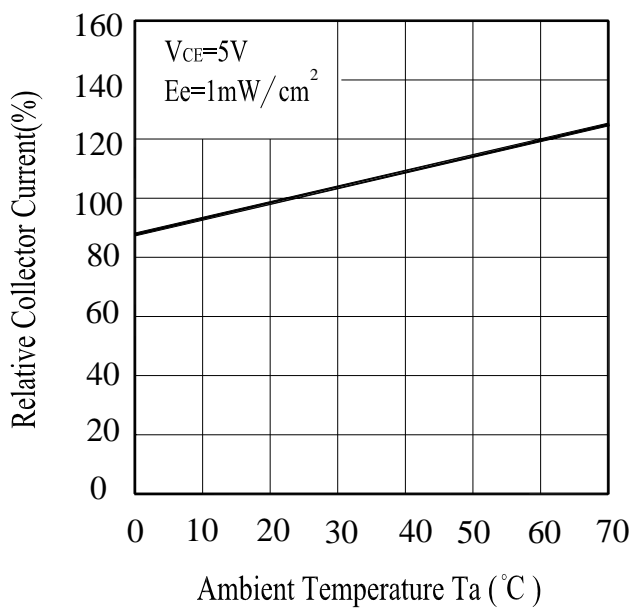
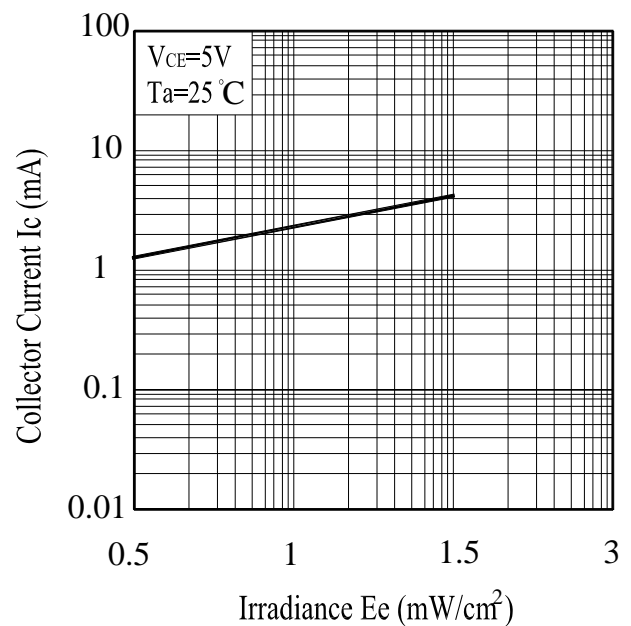

Fig.4 Collector Current vs. Irradiance



Typical Electro-Optical Characteristics Curves

Fig.5 Collector Dark Current vs. Ambient Temperature

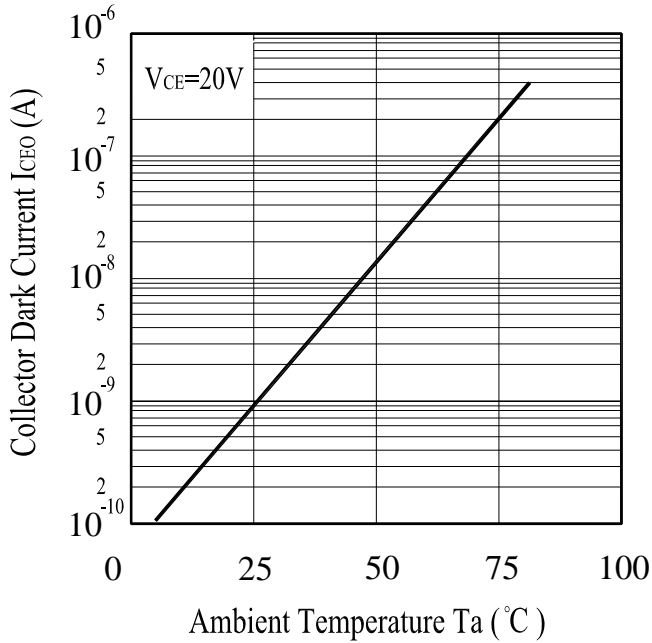
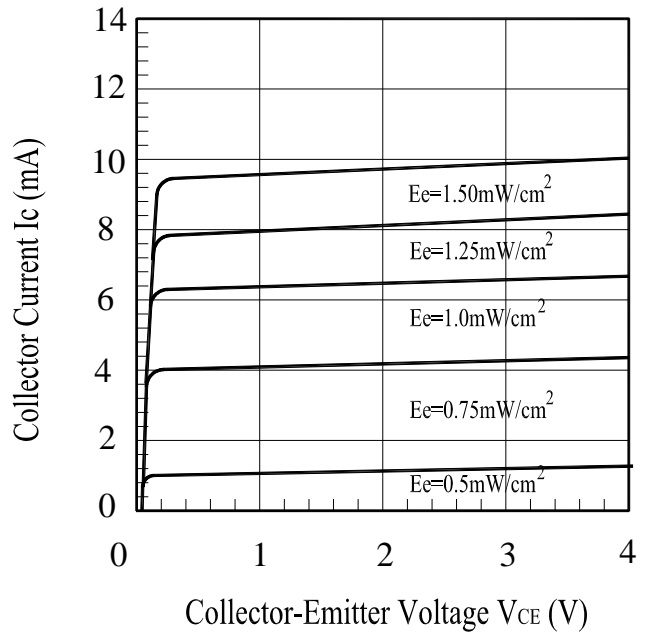

Fig.6 Collector Current vs. Collector-Emitter Voltage



Reliability Test Item And Condition

The reliability of products shall be satisfied with items listed below.

Confidence level : 90%

LTPD : 10%

| NO. | Item | Test Conditions | Test Hours/ Cycles | Sample Sizes | Failure Judgement Criteria | Ac/Re |
|-----|------------------------------------|--|-----------------------|-----------------|--|-------|
| 1 | Solder Heat | TEMP. : 260°C±5°C | 10secs | 22pcs | $I_{C(ON)} \leq L \times 0.8$ L : Lower Specification Limit | 0/1 |
| 2 | Temperature Cycle | H : +100°C 15mins ↑ 5mins ↓ L : -40°C 15mins | 300Cycles | 22pcs | | 0/1 |
| 3 | Thermal Shock | H : +100°C 5mins ↑ 10secs ↓ L : -10°C 5mins | 300Cycles | 22pcs | | 0/1 |
| 4 | High Temperature Storage | TEMP. : +100°C | 1000hrs | 22pcs | | 0/1 |
| 5 | Low Temperature Storage | TEMP. : -40°C | 1000hrs | 22pcs | | 0/1 |
| 6 | DC Operating Life | $V_{CE}=5V$ | 1000hrs | 22pcs | | 0/1 |
| 7 | High Temperature/ High Humidity | 85°C / 85% R.H | 1000hrs | 22pcs | | 0/1 |

Packing Quantity Specification

1.500PCS/1Bag , 5Bags/1Box

2.10Boxes/1Carton

Label Form Specification

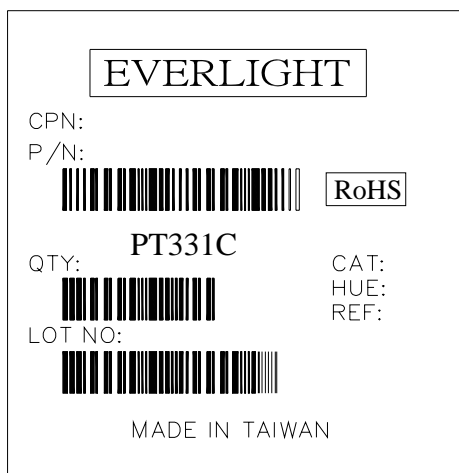

CPN: Customer's Production Number

P/N : Production Number

QTY: Packing Quantity

CAT: Ranks

HUE: Peak Wavelength

REF: Reference

LOT No: Lot Number

MADE IN TAIWAN: Production Place

Notes

1. Above specification may be changed without notice. EVERLIGHT will reserve authority on material change for above specification.
2. When using this product, please observe the absolute maximum ratings and the instructions for using outlined in these specification sheets. EVERLIGHT assumes no responsibility for any damage resulting from use of the product which does not comply with the absolute maximum ratings and the instructions included in these specification sheets.
3. These specification sheets include materials protected under copyright of EVERLIGHT corporation. Please don't reproduce or cause anyone to reproduce them without EVERLIGHT's consent.

EVERLIGHT ELECTRONICS CO., LTD.

Office: No 25, Lane 76, Sec 3, Chung Yang Rd,

Tucheng, Taipei 236, Taiwan, R.O.C

Tel: 886-2-2267-2000, 2267-9936

Fax: 886-2267-6244, 2267-6189, 2267-6306

<http://www.everlight.com>