

1 Form A Solid State Relay

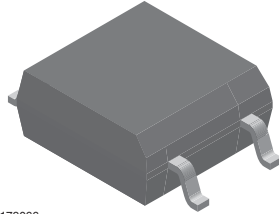

i179066

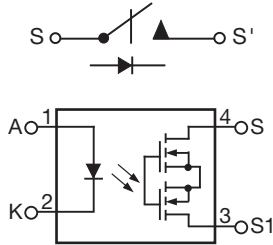

20050

FEATURES

- Maximum R_{ON} 5 Ω
- Load voltage 60 V
- Load current 100 mA
- Isolation test voltage 1500 V_{RMS}
- Small 4 pin SOP package
- Clean bounce free switching
- TTL/CMOS compatible input
- High reliability hybrid receptor
- Available on tape and reel
- Compliant to RoHS Directive 2002/95/EC and in accordance to WEEE 2002/96/EC

RoHS
COMPLIANT

APPLICATIONS

- Security systems
- Instrumentation
- Industrial controls

AGENCY APPROVALS

UL: file no. E300068 system code K

cUL: file no. E300068

Note

- IEC 60747-5-2 (VDE 0884) capable, consult sales representative for details

DESCRIPTION

The VO1400AEFTR is an optically isolated 1 form A solid-state relay in a surface mount 4 pin SOP package.

ORDERING INFORMATION

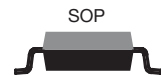
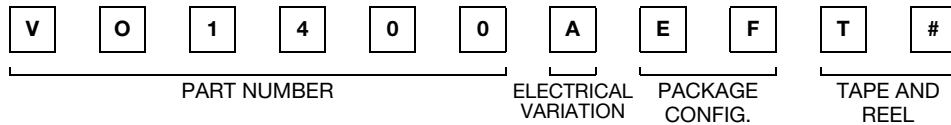

PACKAGE	UL, cUL
SOP-4, Tape and reel	VO1400AEFTR
SOP-4, Tape and reel (product rotated in tape)	VO1400AEFT2

ABSOLUTE MAXIMUM RATINGS ($T_{amb} = 25\text{ }^{\circ}\text{C}$, unless otherwise specified)

PARAMETER	TEST CONDITION	SYMBOL	VALUE	UNIT
INPUT				
LED continuous forward current		I_F	50	mA
LED reverse voltage		V_R	5	V
OUTPUT				
DC or peak AC load voltage		V_L	60	V
Load current AC peak		I_L	100	mA
Peak load current	$t = 10\text{ ms}$	I_{LPK}	350	mA
SSR				
Total power dissipation		P_{diss}	400	mW
Ambient temperature range		T_{amb}	- 40 to + 85	$^{\circ}\text{C}$
Storage temperature range		T_{stg}	- 40 to + 125	$^{\circ}\text{C}$
Soldering temperature ⁽¹⁾	$t \leq 10\text{ s max.}$	T_{sld}	260	$^{\circ}\text{C}$
Isolation test voltage	$t = 1\text{ s}$	V_{ISO}	1500	V_{RMS}

Notes

- Stresses in excess of the absolute maximum ratings can cause permanent damage to the device. Functional operation of the device is not implied at these or any other conditions in excess of those given in the operational sections of this document. Exposure to absolute maximum ratings for extended periods of the time can adversely affect reliability.

⁽¹⁾ Refer to reflow profile for soldering conditions for surface mounted devices.

ABSOLUTE MAXIMUM RATING CURVE

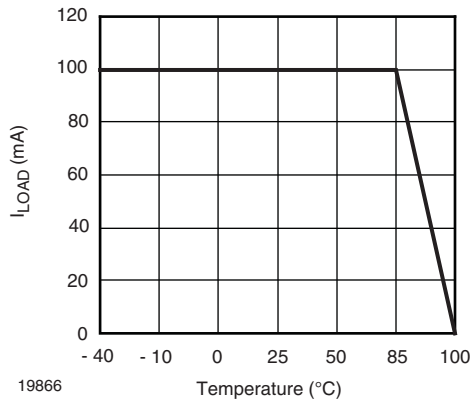
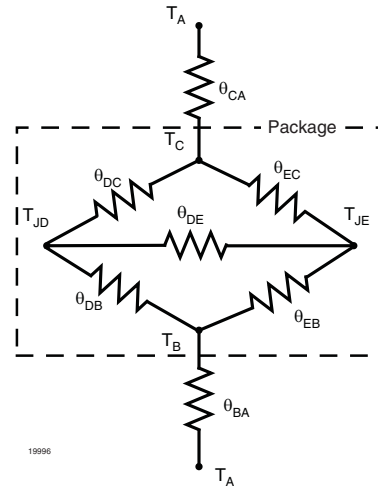

Fig. 1 - I_{LOAD} vs. Temperature

THERMAL CHARACTERISTICS			
PARAMETER	SYMBOL	VALUE	UNIT
LED power dissipation	P_{diss}	60	mW
Output power dissipation	P_{diss}	50	mW
Total power dissipation	P_{tot}	110	mW
Maximum LED junction temperature	$T_{jmax.}$	125	°C
Maximum output die junction temperature	$T_{jmax.}$	125	°C
Thermal resistance, junction emitter to board	θ_{JEB}	114	°C/W
Thermal resistance, junction emitter to case	θ_{JEC}	99	°C/W
Thermal resistance, junction detector to board	θ_{JDB}	60	°C/W
Thermal resistance, junction detector to case	θ_{JDC}	80	°C/W
Thermal resistance, junction emitter to junction detector	θ_{JED}	115	°C/W
Thermal resistance, case to ambient	θ_{CA}	2396	°C/W



Note

- The thermal model is represented in the thermal network below. Each resistance value given in this model can be used to calculate the temperatures at each node for a given operating condition. The thermal resistance from board to ambient will be dependent on the type of PCB, layout and thickness of copper traces. For a detailed explanation of the thermal model, please reference Vishay's Thermal Characteristics of Optocouplers application note.

ELECTRICAL CHARACTERISTICS ($T_{amb} = 25\text{ }^{\circ}\text{C}$, unless otherwise specified)						
PARAMETER	TEST CONDITION	SYMBOL	MIN.	TYP.	MAX.	UNIT
INPUT						
LED forward current, switch turn-on	$I_L = 100\text{ mA}$, $V_L \leq 0.5\text{ V}$, $t = 10\text{ ms}$	I_{Fon}	0.3	1	3.2	mA
LED forward current, switch turn-off	$V_L = 60\text{ V}$	I_{Foff}	100	150		μA
LED reverse current	$V_R = 5\text{ V}$	I_R		0.001	10	μA
LED forward voltage	$I_F = 5\text{ mA}$	V_F	0.8	1.1	1.4	V
LED reverse voltage	$I_R = 10\text{ }\mu\text{A}$	V_R	5	40		V
OUTPUT						
On-resistance	$I_F = 10\text{ mA}$, $I_L = 100\text{ mA}$	R_{ON}		2.3	5	Ω
Off-state leakage current	$I_F = 0\text{ mA}$, $V_L = 60\text{ V}$	I_{LEAK}		0.002	1	μA

Note

- Minimum and maximum values are testing requirements. Typical values are characteristics of the device and are the result of engineering evaluations. Typical values are for information only and are not part of the testing requirements.

SWITCHING CHARACTERISTICS						
PARAMETER	TEST CONDITION	SYMBOL	MIN.	TYP.	MAX.	UNIT
Turn-on time	$I_F = 10\text{ mA}$, $V_L = 20\text{ V}$, $I_L = 100\text{ mA}$	t_{on}		52	500	μs
Turn-off time	$I_F = 10\text{ mA}$, $V_L = 20\text{ V}$, $I_L = 100\text{ mA}$	t_{off}		36	500	μs

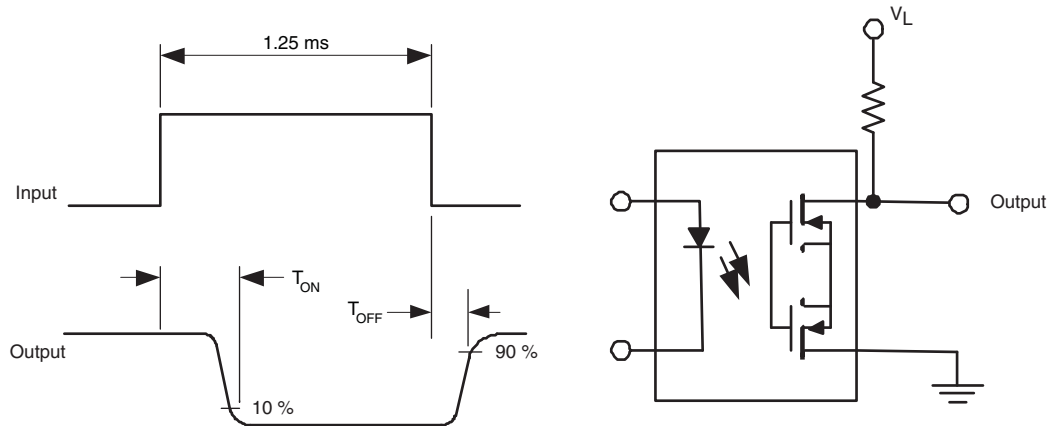

20991-1

SAFETY AND INSULATION RATINGS				
PARAMETER	TEST CONDITION	SYMBOL	VALUE	UNIT
Climatic classification	IEC 68 part 1		40/85/21	
Pollution degree	DIN VDE 0109		2	
Tracking resistance (comparative tracking index)	Insulation group IIIa	CTI	175	
Highest allowable overvoltage	Transient overvoltage	V_{IOTM}	6000	V_{peak}
Maximum working insulation voltage	Recurring peak voltage	V_{IORM}	707	V_{peak}
Insulation resistance at 25 °C	$V_{IO} = 500\text{ V}$	R_{IS}	$\geq 10^{12}$	Ω
Insulation resistance at T_S	$V_{IO} = 500\text{ V}$	R_{IS}	$\geq 10^9$	Ω
Insulation resistance at 100 °C	$V_{IO} = 500\text{ V}$	R_{IS}	$\geq 10^{11}$	Ω
Partial discharge test voltage	Method a, $V_{pd} = V_{IORM} \times 1.875$	V_{pd}	1325	V_{peak}
Isolation test voltage, 1 s		V_{RMS}	1800	V_{RMS}
Safety limiting values - maximum values allowed in the event of a failure	Output power	P_{SO}	400	mW
	Input current	I_{SI}	150	mA
	Case temperature	T_{SI}	165	°C
Minimum external air gap (clearance distance)	Measured from input terminals to output terminals, shortest distance through air		≥ 5	mm
Minimum external tracking (creepage distance)	Measured from input terminals to output terminals, shortest distance path along body		≥ 5	mm

Note

- This SSR is suitable for "safe electrical insulation" only within the safety ratings. Compliance with the safety ratings shall be ensured by means of protective circuits.

TYPICAL CHARACTERISTICS ($T_{amb} = 25\text{ °C}$, unless otherwise specified)

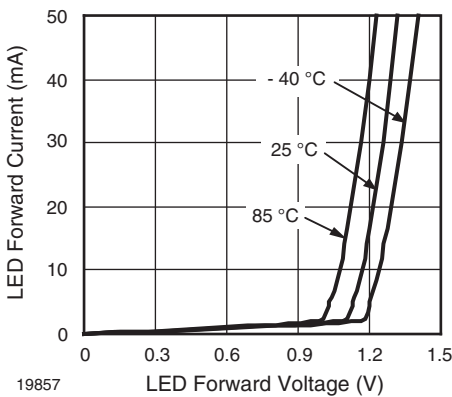

Fig. 2 - Typical LED Forward Voltage vs. Current

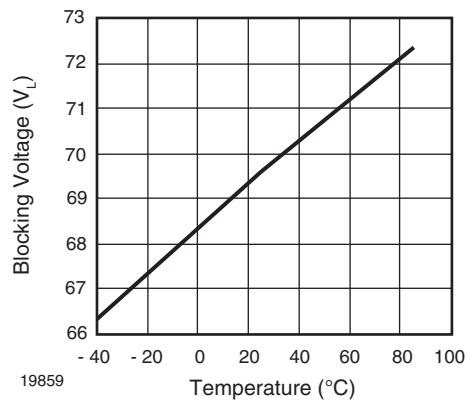

Fig. 3 - Typical Blocking Voltage vs. Temperature

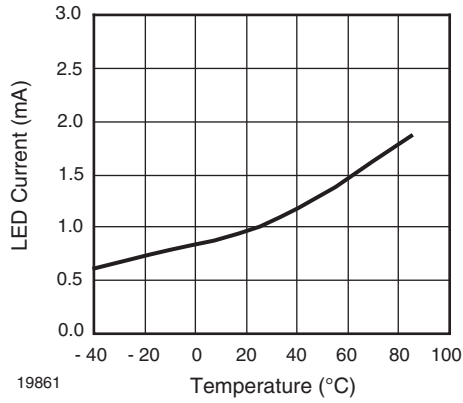

Fig. 4 - Typical I_F for Switch Operation vs. Temperature (Load Current = 100 mA)

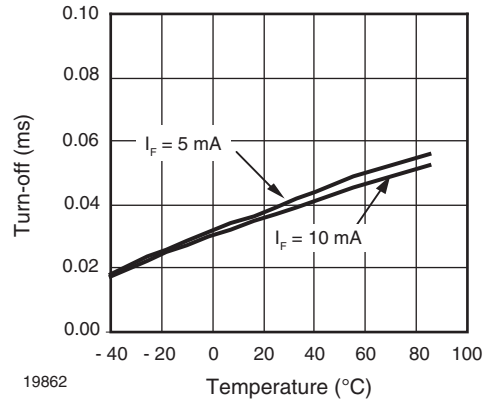

Fig. 7 - Typical Turn-off vs. Temperature (Load Current = 100 mA)

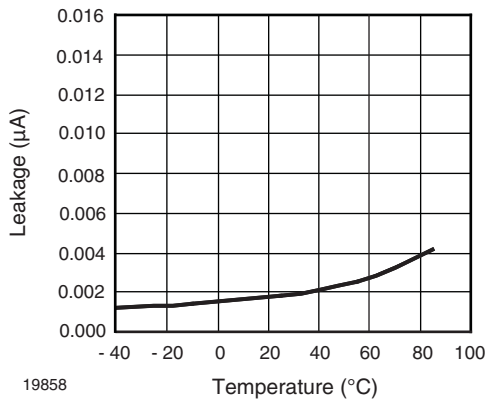

Fig. 5 - Typical Leakage vs. Temperature ($V_L = 60 V$)

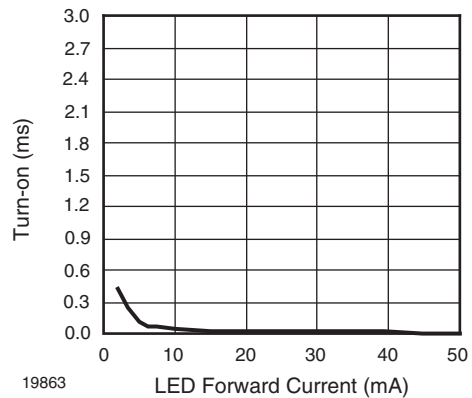

Fig. 8 - Typical Turn-on vs. LED Forward Current (Load Current = 100 mA)

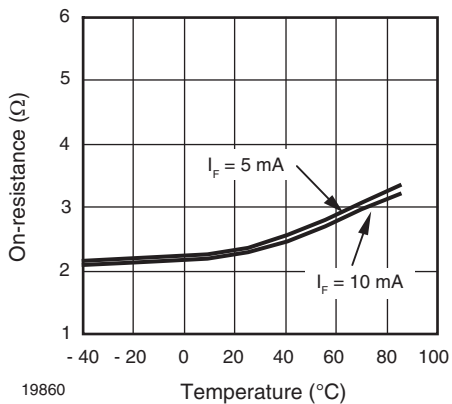

Fig. 6 - Typical On-resistance vs. Temperature (Load Current = 100 mA)

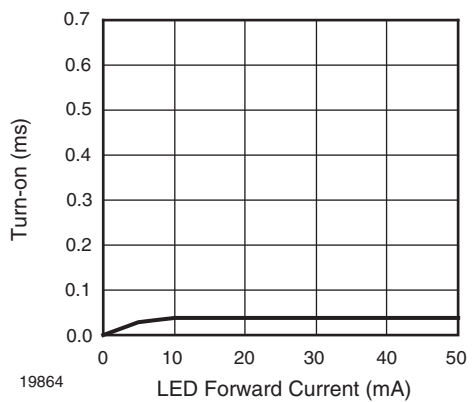
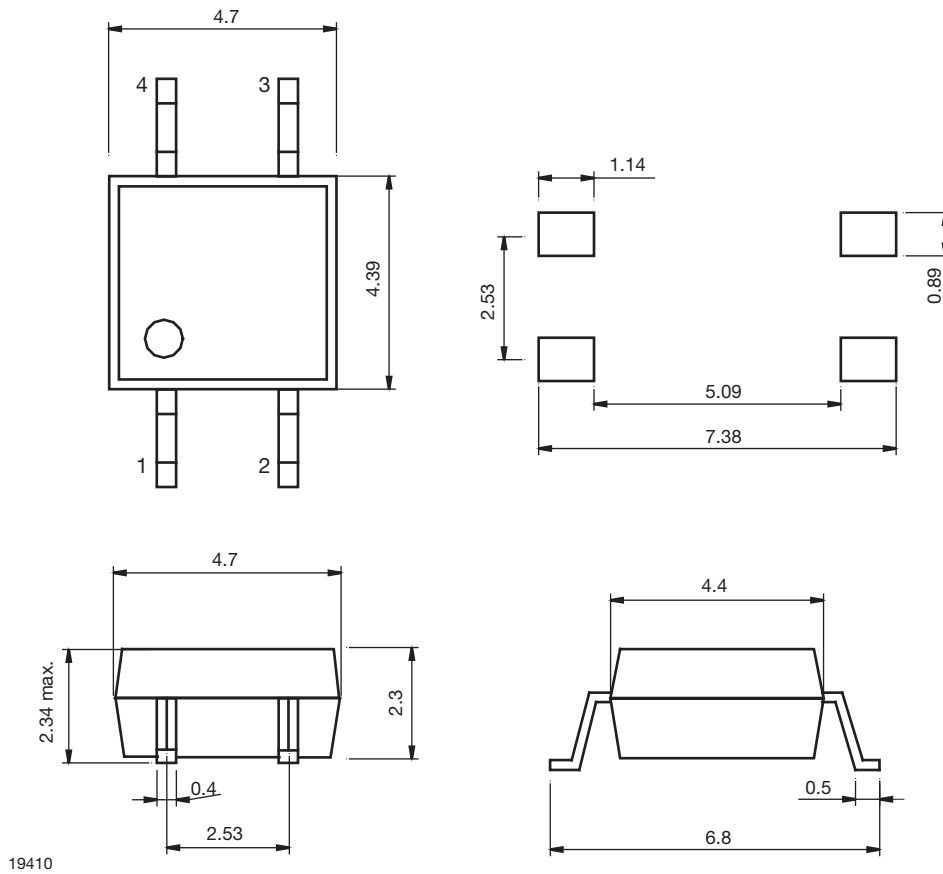

Fig. 9 - Typical Turn-off vs. LED Forward Current (Load Current = 100 mA)

PACKAGE DIMENSIONS in millimeters



PACKAGE MARKING



Note

- Tape and reel suffix (TR) is not part of the package marking.

ESD CAUTION

This is an ESD (electro static discharge) sensitive device. Electrostatic charges accumulate on the human body and test equipment and can discharge without detection. Therefore, proper ESD precautions are recommended to avoid performance degradation or loss of functionality. ESD withstand voltage of this device is up to 1500 V acc. to JESD22-A114-B.



20055_1



Disclaimer

ALL PRODUCT, PRODUCT SPECIFICATIONS AND DATA ARE SUBJECT TO CHANGE WITHOUT NOTICE TO IMPROVE RELIABILITY, FUNCTION OR DESIGN OR OTHERWISE.

Vishay Intertechnology, Inc., its affiliates, agents, and employees, and all persons acting on its or their behalf (collectively, "Vishay"), disclaim any and all liability for any errors, inaccuracies or incompleteness contained in any datasheet or in any other disclosure relating to any product.

Vishay makes no warranty, representation or guarantee regarding the suitability of the products for any particular purpose or the continuing production of any product. To the maximum extent permitted by applicable law, Vishay disclaims (i) any and all liability arising out of the application or use of any product, (ii) any and all liability, including without limitation special, consequential or incidental damages, and (iii) any and all implied warranties, including warranties of fitness for particular purpose, non-infringement and merchantability.

Statements regarding the suitability of products for certain types of applications are based on Vishay's knowledge of typical requirements that are often placed on Vishay products in generic applications. Such statements are not binding statements about the suitability of products for a particular application. It is the customer's responsibility to validate that a particular product with the properties described in the product specification is suitable for use in a particular application. Parameters provided in datasheets and/or specifications may vary in different applications and performance may vary over time. All operating parameters, including typical parameters, must be validated for each customer application by the customer's technical experts. Product specifications do not expand or otherwise modify Vishay's terms and conditions of purchase, including but not limited to the warranty expressed therein.

Except as expressly indicated in writing, Vishay products are not designed for use in medical, life-saving, or life-sustaining applications or for any other application in which the failure of the Vishay product could result in personal injury or death. Customers using or selling Vishay products not expressly indicated for use in such applications do so at their own risk and agree to fully indemnify and hold Vishay and its distributors harmless from and against any and all claims, liabilities, expenses and damages arising or resulting in connection with such use or sale, including attorneys fees, even if such claim alleges that Vishay or its distributor was negligent regarding the design or manufacture of the part. Please contact authorized Vishay personnel to obtain written terms and conditions regarding products designed for such applications.

No license, express or implied, by estoppel or otherwise, to any intellectual property rights is granted by this document or by any conduct of Vishay. Product names and markings noted herein may be trademarks of their respective owners.

Material Category Policy

Vishay Intertechnology, Inc. hereby certifies that all its products that are identified as RoHS-Compliant fulfill the definitions and restrictions defined under Directive 2011/65/EU of The European Parliament and of the Council of June 8, 2011 on the restriction of the use of certain hazardous substances in electrical and electronic equipment (EEE) - recast, unless otherwise specified as non-compliant.

Please note that some Vishay documentation may still make reference to RoHS Directive 2002/95/EC. We confirm that all the products identified as being compliant to Directive 2002/95/EC conform to Directive 2011/65/EU.

Mouser Electronics

Authorized Distributor

Click to View Pricing, Inventory, Delivery & Lifecycle Information:

[Vishay:](#)

[VO1400AEFTR](#)