

Table of Contents

1 Features	1	8.2 Functional Block Diagram	7
2 Applications	1	8.3 Feature Description	8
3 Description	1	8.4 Device Functional Modes	8
4 Circuit Protection Scheme	1	9 Application and Implementation	9
5 Revision History	2	9.1 Application Information	9
6 Pin Configuration and Functions	3	9.2 Typical Application	9
7 Specifications	4	10 Power Supply Recommendations	10
7.1 Absolute Maximum Ratings	4	11 Layout	11
7.2 Handling Ratings	4	11.1 Layout Guidelines	11
7.3 Recommended Operating Conditions	4	11.2 Layout Example	11
7.4 Thermal Information	4	12 Device and Documentation Support	12
7.5 Electrical Characteristics	5	12.1 Trademarks	12
7.6 Typical Characteristics	6	12.2 Electrostatic Discharge Caution	12
8 Detailed Description	7	12.3 Glossary	12
8.1 Overview	7	13 Mechanical, Packaging, and Orderable Information	12

5 Revision History

Changes from Revision C (January 2013) to Revision D

Page

- Added Handling Rating table, Feature Description section, Device Functional Modes, Application and Implementation section, Power Supply Recommendations section, Layout section, Device and Documentation Support section, and Mechanical, Packaging, and Orderable Information section. **1**

6 Pin Configuration and Functions

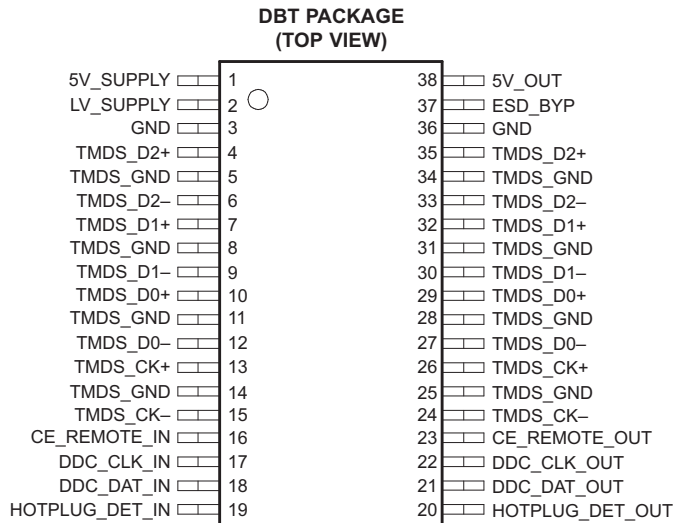

Pin Functions

PIN		TYPE	ESD	DESCRIPTION
NAME	NO.			
5V_SUPPLY	1	PWR	2 kV ⁽¹⁾	Current source for 5V_OUT.
LV_SUPPLY	2			Bias for CE/DDC/HOTPLUG level shifters.
GND, TMDS_GND	3, 5, 8, 11, 14, 25, 28, 31, 34, 36	GND	NA	TMDS ESD and parasitic GND return.
TMDS_D2+	4, 35	ESD clamp	8 kV ⁽²⁾	TMDS 0.8-pF ESD protection. ⁽³⁾
TMDS_D2-	6, 33			
TMDS_D1+	7, 32			
TMDS_D1-	9, 30			
TMDS_D0+	10, 29			
TMDS_D0-	12, 27			
TMDS_CK+	13, 26			
TMDS_CK-	15, 24			
CE_REMOTE_IN	16	IO	2 kV ⁽¹⁾	LV_SUPPLY referenced logic level into ASIC.
DDC_CLK_IN	17			
DDC_DAT_IN	18			
HOTPLUG_DET_IN	19			
HOTPLUG_DET_OUT	20	IO, ESD clamp	8 kV ⁽²⁾	5 V_SUPPLY referenced logic level out, plus 3.5-pF ESD ⁽⁴⁾ to connector.
DDC_DAT_OUT	21			5 V_SUPPLY referenced logic level out, plus 3.5-pF ESD to connector.
DDC_CLK_OUT	22			
CE_REMOTE_OUT	23	ESD Bypass	2 kV ⁽¹⁾	ESD bypass. This pin must be connected to a 0.1-μF ceramic capacitor.
ESD_BYP	37			
5V_OUT	38	PWR	2 kV ⁽¹⁾	5-V regulator output

(1) Human-Body Model (HBM) per MIL-STD-883C, Method 3015, $C_{DISCHARGE} = 100$ pF, $R_{DISCHARGE} = 1.5$ kΩ, 5V_SUPPLY and LV_SUPPLY within recommended operating conditions, GND = 0 V, and ESD_BYP (pin 37) and HOTPLUG_DET_OUT (pin 20) each bypassed with a 0.1-μF ceramic capacitor connected to GND.

(2) Standard IEC 61000-4-2, $C_{DISCHARGE} = 150$ pF, $R_{DISCHARGE} = 330$ Ω, 5V_SUPPLY and LV_SUPPLY within recommended operating conditions, GND = 0 V, and ESD_BYP (pin 37) and HOTPLUG_DET_OUT (pin 20) each bypassed with a 0.1-μF ceramic capacitor connected to GND.

(3) These two pins must be connected together inline on the PCB.

(4) This output can be connected to an external 0.1-μF ceramic capacitor, resulting in an increased ESD withstand voltage rating.

7 Specifications

7.1 Absolute Maximum Ratings⁽¹⁾⁽²⁾

over operating free-air temperature range (unless otherwise noted)

		MIN	MAX	UNIT
V _{5V_SUPPLY}	Supply voltage	-0.3	6	V
V _{LV_SUPPLY}				
V _{I/O}	DC voltage at any channel input	-0.5	6	V

- (1) Stresses beyond those listed under "absolute maximum ratings" may cause permanent damage to the device. These are stress ratings only, and functional operation of the device at these or any other conditions beyond those indicated under "recommended operating conditions" is not implied. Exposure to absolute-maximum-rated conditions for extended periods may affect device reliability.
- (2) The algebraic convention, whereby the most negative value is a minimum and the most positive value is a maximum.

7.2 Handling Ratings

			MIN	MAX	UNIT
T _{stg}	Storage temperature range		-65	150	°C
V _(ESD)	Electrostatic discharge	Human body model (HBM), per MIL-STD-883, Method 3015, C _{DISCHARGE} = 100 pF, R _{DISCHARGE} = 1.5 kΩ	-2	+2	kV
		IEC 61000-4-2 Contact Discharge	-8	+8	kV

7.3 Recommended Operating Conditions

over operating free-air temperature range (unless otherwise noted)

		MIN	TYP	MAX	UNIT
T _A	Operating free-air temperature	-40		85	°C
5V_SUPPLY	Operating supply voltage		5	5.5	V
LV_SUPPLY	Bias supply voltage	1	3.3	5.5	V

7.4 Thermal Information

THERMAL METRIC ⁽¹⁾		TPD12S521	UNIT
		DBT	
		38 PINS	
R _{θJA}	Junction-to-ambient thermal resistance	83.6	°C/W
R _{θJC(top)}	Junction-to-case (top) thermal resistance	29.8	
R _{θJB}	Junction-to-board thermal resistance	44.7	
ψ _{JT}	Junction-to-top characterization parameter	2.9	
ψ _{JB}	Junction-to-board characterization parameter	44.1	

- (1) For more information about traditional and new thermal metrics, see the *IC Package Thermal Metrics* application report, [SPRA953](#).

7.5 Electrical Characteristics

over operating free-air temperature range (unless otherwise noted)

PARAMETER		TEST CONDITIONS		MIN	TYP	MAX	UNIT
I_{CC5}	Operating supply current	5V_SUPPLY = 5 V			110	130	μ A
I_{CC3}	Bias supply current	LV_SUPPLY = 3.3 V			1	5	μ A
V_{DROP}	5V_OUT overcurrent output drop	5V_SUPPLY = 5 V, $I_{OUT} = 55$ mA			150	200	mV
I_{SC}	5V_OUT short-circuit current limit	5V_SUPPLY = 5 V, 5V_OUT = GND		90	135	175	mA
I_{OFF}	OFF-state leakage current, level-shifting NFET	LV_SUPPLY = 0 V			0.1	5	μ A
$I_{BACK\ DRIVE}$	Current conducted from output pins to V_SUPPLY rails when powered down	$5V_SUPPLY < V_{CH_OUT}$	TMDS_D[2:0] +/-, TMDS_CK +/-, CE_REMOTE_OUT, DDC_DAT_OUT, DDC_CLK_OUT, HOTPLUG_DET_OUT		0.1	5	μ A
V_{ON}	Voltage drop across level-shifting NFET when ON	LV_SUPPLY = 2.5 V, $V_S = GND$, $I_{DS} = 3$ mA		75	95	140	mV
V_F	Diode forward voltage	$I_F = 8$ mA, $T_A = 25^\circ\text{C}^{(1)}$	Top diode	0.85			V
			Bottom diode	0.85			
V_{CL}	Channel clamp voltage at ± 8 kV HBM ESD	$T_A = 25^\circ\text{C}^{(1)(2)}$	Positive transients	9			V
			Negative transients	-9			
R_{DYN}	Dynamic resistance	$I = 1$ A, $T_A = 25^\circ\text{C}^{(3)}$	Positive transients	3			Ω
			Negative transients	1.5			
I_{LEAK}	TMDS channel leakage current	$T_A = 25^\circ\text{C}^{(1)}$			0.01	1	μ A
$C_{IN, TMDS}$	TMDS channel input capacitance	5V_SUPPLY = 5 V, Measured at 1 MHz, $V_{BIAS} = 2.5$ V ⁽¹⁾			0.8	1.0	pF
$\Delta C_{IN, TMDS}$	TMDS channel input capacitance matching	5V_SUPPLY = 5 V, Measured at 1 MHz, $V_{BIAS} = 2.5$ V ⁽¹⁾⁽⁴⁾			0.05		pF
C_{MUTUAL}	Mutual capacitance between signal pin and adjacent signal pin	5V_SUPPLY = 0 V, Measured at 1 MHz, $V_{BIAS} = 2.5$ V ⁽¹⁾			0.07		pF
C_{IN}	Level-shifting input capacitance, capacitance to GND	5V_SUPPLY = 0 V, Measured at 100 KHz, $V_{BIAS} = 2.5$ V ⁽¹⁾	DDC	3.5	4		pF
			CEC	3.5	4		
			HP	3.5	4		

(1) This parameter is specified by design and verified by device characterization

 (2) Human-Body Model (HBM) per MIL-STD-883, Method 3015, $C_{DISCHARGE} = 100$ pF, $R_{DISCHARGE} = 1.5$ k Ω

(3) These measurements performed with no external capacitor on ESD_BYP.

(4) Intrapair matching, each TMDS pair (i.e., D+, D-)

7.6 Typical Characteristics

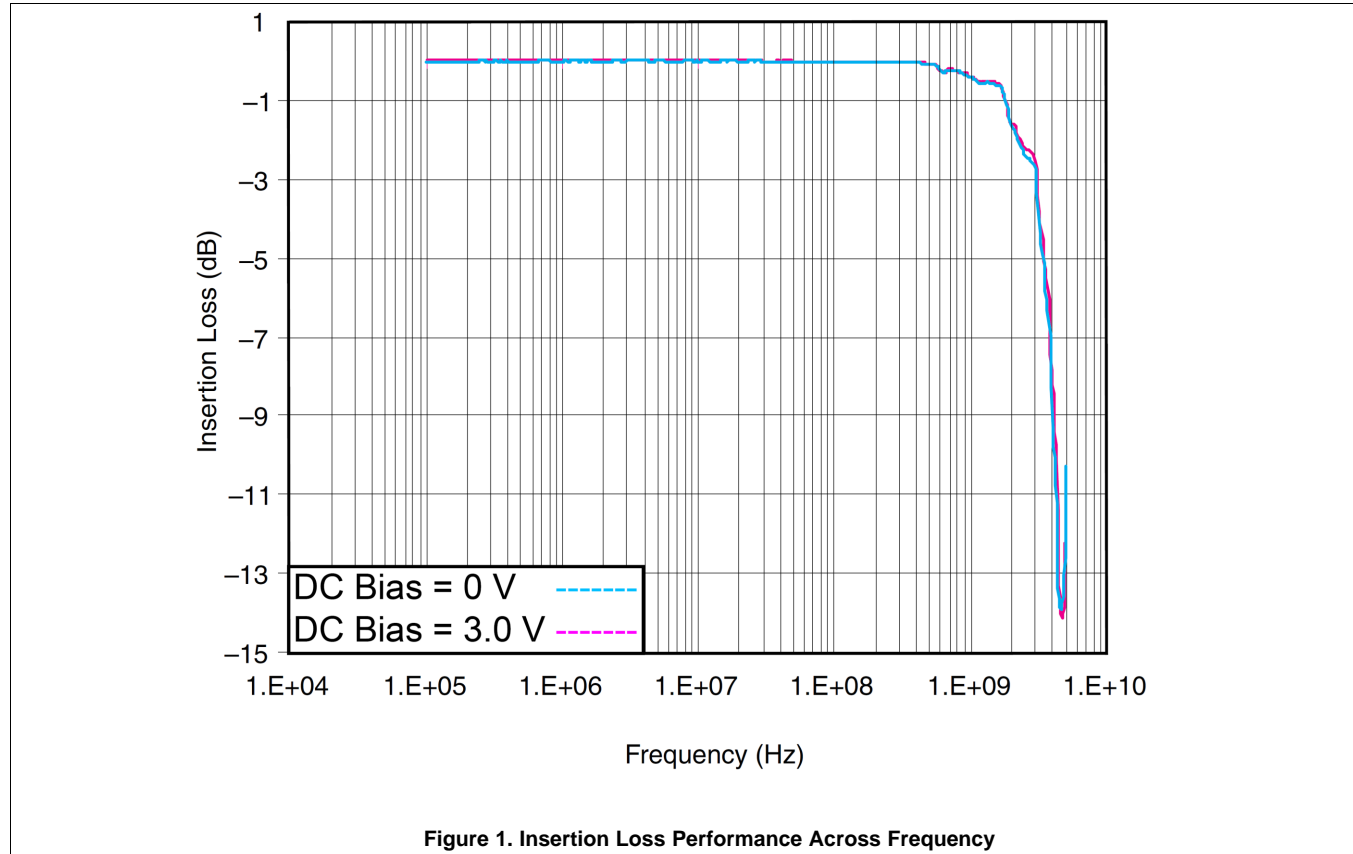

8 Detailed Description

8.1 Overview

The TPD12S521 is a single-chip ESD solution for the HDMI transmitter port. In many cases the core ICs, such as the scalar chipset, may not have robust ESD cells to sustain system-level ESD strikes. In these cases, the TPD12S521 provides the desired system-level ESD protection, such as the IEC61000-4-2 (Level 4) ESD, by absorbing the energy associated with the ESD strike.

While providing the ESD protection, the TPD12S521 adds little or no additional glitch in the high-speed differential signals (see Figure 5 and Figure 6). The high-speed TMDS lines add only 0.8-pF capacitance to the lines. In addition, the monolithic integrated circuit technology ensures that there is excellent matching between the two-signal pair of the differential line. This is a direct advantage over discrete ESD clamp solutions where variations between two different ESD clamps may significantly degrade the differential signal quality.

The low-speed control lines offer voltage-level shifting to eliminate the need for an external voltage level-shifter IC. The control line ESD clamps add 3.5-pF capacitance to the control lines. The 38-pin DBT package offers a seamless layout routing option to eliminate the routing glitch for the differential signal pairs.

The TPD12S521 provides an on-chip regulator with current output ratings of 55 mA at pin 38. This current enables HDMI receiver detection even when the receiver device is powered off. DBT package pitch (0.5 mm) matches with HDMI connector pitch. In addition, pin mapping follows the same order as the HDMI connector pin mapping.

8.2 Functional Block Diagram

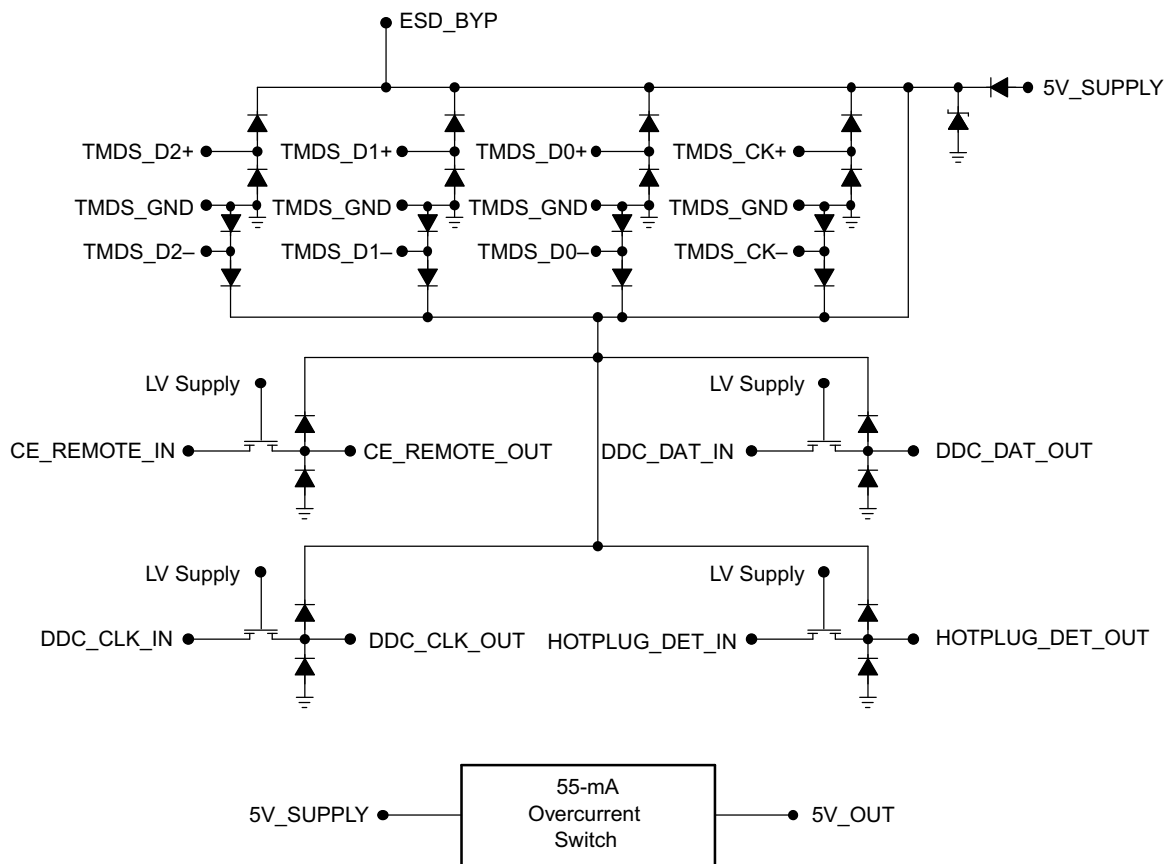

8.3 Feature Description

8.3.1 Single-Chip ESD Solution for HDMI Driver

TPD12S521 provides a complete ESD protection scheme for an HDMI 1.4 compliant port. The monolithic integrated circuit technology ensures that there is excellent matching between the two-signal pair of the differential line. This is a direct advantage over discrete ESD clamp solutions where variations between two different ESD clamps may significantly degrade the differential signal quality. The 38-pin DBT package offers a seamless layout routing option to eliminate the routing glitch for the differential signal pair.

8.3.2 Supports HDMI 1.3 and HDMI 1.4 Data Rates

The high-speed TMDS pins of the TPD12S521 add only 0.8 pF of capacitance to the TMDS lines. Excellent intra-pair capacitance matching of 0.05 pF provides ultra low intra-pair skew. Insertion loss -3 dB point > 3 GHz provides enough bandwidth to pass HDMI 1.4 TMDS data rates.

8.3.3 Integrated Level Shifting for the Control Lines

The low-speed control lines offer voltage-level shifting to eliminate the need for an external voltage level-shifter IC. The control line ESD clamps add 3.5-pF capacitance to the control lines.

8.3.4 ±8-kV Contact ESD Protection on External Lines

In many cases, the core ICs, such as the scalar chipset, may not have robust ESD cells to sustain system-level ESD strikes. In these cases, the TPD12S521 provides the desired system-level ESD protection, such as the the IEC61000-4-2 (Level 4) ESD, by absorbing the energy associated with the ESD strike.

8.3.5 38-Pin TSSOP Provides Seamless Layout Option With HDMI Connector

The 38-pin DBT package offers seamless layout routing option to eliminate the routing glitch for the differential signal pair. DBT package pitch (0.5 mm) matches with HDMI connector pitch. In addition, pin mapping follows the same order as the HDMI connector pin mapping. This HDMI receiver port protection and interface device is specifically designed for next-generation HDMI transmitter protection.

8.3.6 Backdrive Protection

Backdrive protection is offered on the following pins: TMDS_D[2:0]±/, TMDS_CK±/, CE_REMOTE_OUT, DDC_DAT_OUT, DDC_CLK_OUT, HOTPLUG_DET_OUT.

8.3.7 Lead-Free Package

Lead-Free Package for RoHS Compliance.

8.3.8 On-Chip Current Regulator With 55-mA Current Output

The TPD12S521 provides an on-chip regulator with current output ratings of 55 mA at pin 38. This current enables HDMI receiver detection even when the receiver device is powered off.

8.4 Device Functional Modes

TPD12S521 is active with the conditions in the [Recommended Operating Conditions](#) met. The bi-directional voltage-level translators provide non-inverting level shifting from V_{LV} on the system side to either 5V (for SDA, SCL, HPD), or 3.3 V (for CEC) on the connector side. Each connector side pin has an ESD clamp that triggers when voltages are above V_{BR} or below the lower diode's V_f . During ESD events, voltages as high as ±8-kV (contact ESD) can be directed to ground via the internal diode network. Once the voltages on the protected line fall below these trigger levels (usually within 10's of nano-seconds), these pins revert to a non-conductive state.

9 Application and Implementation

NOTE

Information in the following applications sections is not part of the TI component specification, and TI does not warrant its accuracy or completeness. TI's customers are responsible for determining suitability of components for their purposes. Customers should validate and test their design implementation to confirm system functionality.

9.1 Application Information

TPD12S521 provides IEC61000-4-2 Level 4 Contact ESD rating to the HDMI 1.4 transmitter port. Integrated voltage-level shifting reduces the board space needed to implement the control lines.

9.2 Typical Application

Refer to [Figure 2](#) for a typical schematic for an HDMI 1.4 transmitter port protected with TPD12S521. The eight TMDS data lines (D2+/-, D1+/-, D0+/-, CLK+/-) each have two pins on TPD12S521 to connect to. The TMDS data lines flow through their respective pin pairs, attaching to the passive ESD protection circuitry.

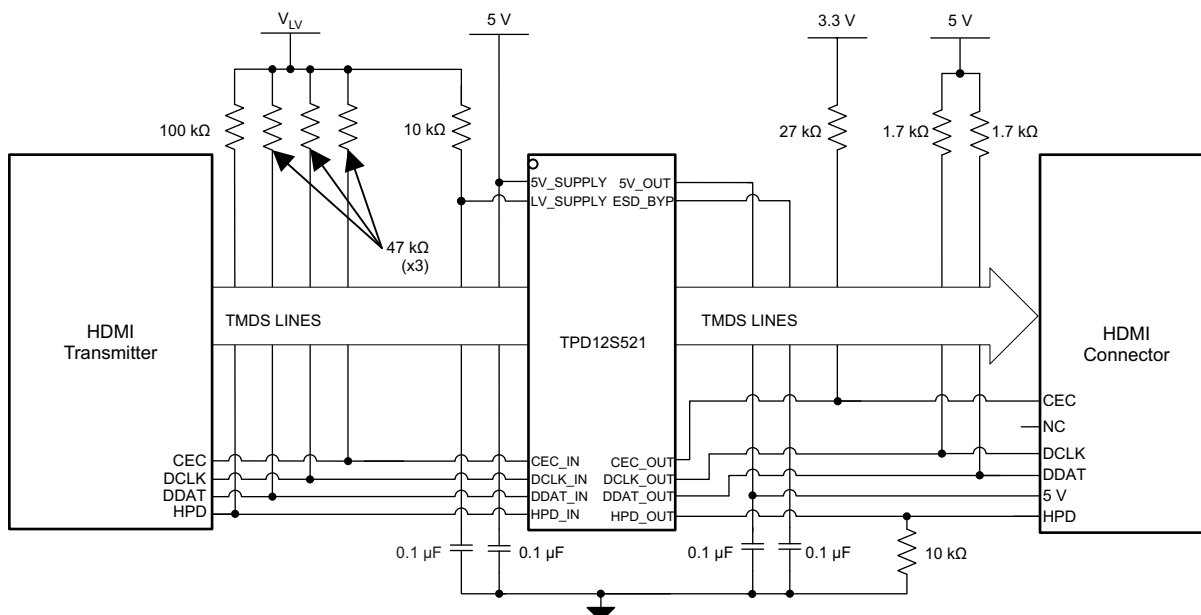

Figure 2. TPD12S521 Configured With an HDMI 1.4 Transmitter Port

9.2.1 Design Requirements

For this example, use the following table as input parameters:

Design Parameters	Example Value
Voltage on 5V_SUPPLY	4.5 V - 5.5 V
Voltage on LV_SUPPLY	1.7 V - 1.9 V

9.2.2 Detailed Design Procedure

To begin the design process the designer needs to know the 5V_SUPPLY voltage range and the logic level, LV_SUPPLY, voltage range.

9.2.3 Application Curves

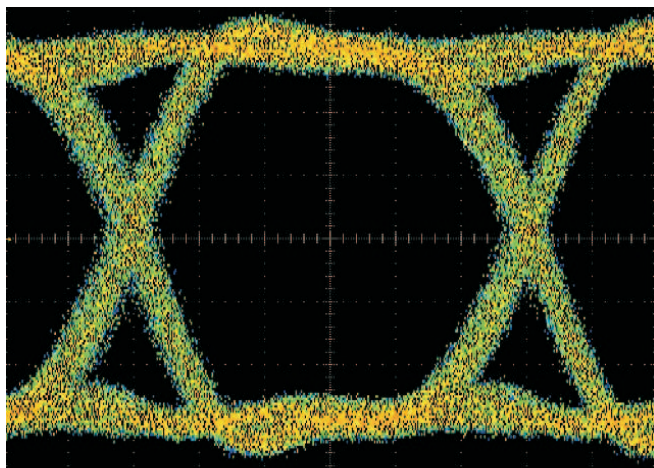

Figure 3. HDMI 1.65Gbps Eye Diagram With TPD12S521 on a Test Board

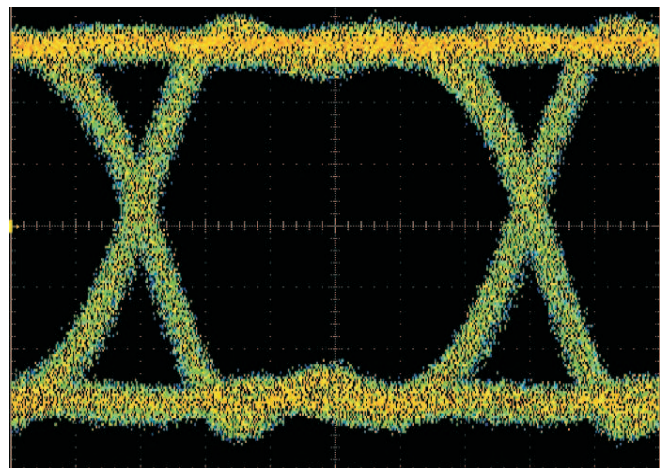

Figure 4. HDMI 1.65Gbps Eye Diagram Without TPD12S521 on a Test Board

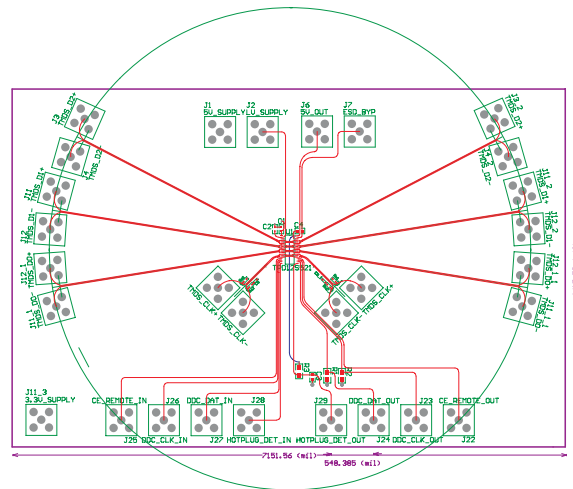

Figure 5. Test Board to Measure Eye Diagram for the TPD12S521 (Refer to Eye Diagram Plot)

10 Power Supply Recommendations

The designer needs to consider the requirement for the HDMI Transmitters Hot Plug Detect (HPD) scheme. If it is a requirement, then the V_{IH} of HPD on the core scalar chip is the minimum voltage needed to detect a Hot Plug event. The minimum voltage requirement is $V_{5V_SUPPLY} - V_{DROP_MAX} - V_{DROP_SYSTEM} - V_{ON_MAX} > V_{IH} \Rightarrow V_{5V_SUPPLY} > V_{IH} + V_{DROP_MAX} + V_{DROP_SYSTEM} + V_{ON_MAX}$; where V_{DROP_MAX} is the maximum voltage drop across TPD12S521's current limiter, V_{DROP_SYSTEM} is the voltage drop across the path from Pin 38 of TPD12S521 through the sink and back to Pin 20, and V_{ON_MAX} is the maximum voltage drop across TPD12S521's level shifting NFET when ON. Otherwise, TPD12S521 is a passive ESD protection device and there is no need to power it.

11 Layout

11.1 Layout Guidelines

- The optimum placement is as close to the connector as possible.
 - EMI during an ESD event can couple from the trace being struck to other nearby unprotected traces, resulting in early system failures.
 - The PCB designer needs to minimize the possibility of EMI coupling by keeping any unprotected traces away from the protected traces which are between the TVS and the connector.
- Route the protected traces as straight as possible.
- Eliminate any sharp corners on the protected traces between the TVS and the connector by using rounded corners with the largest radii possible.
 - Electric fields tend to build up on corners, increasing EMI coupling.

11.2 Layout Example

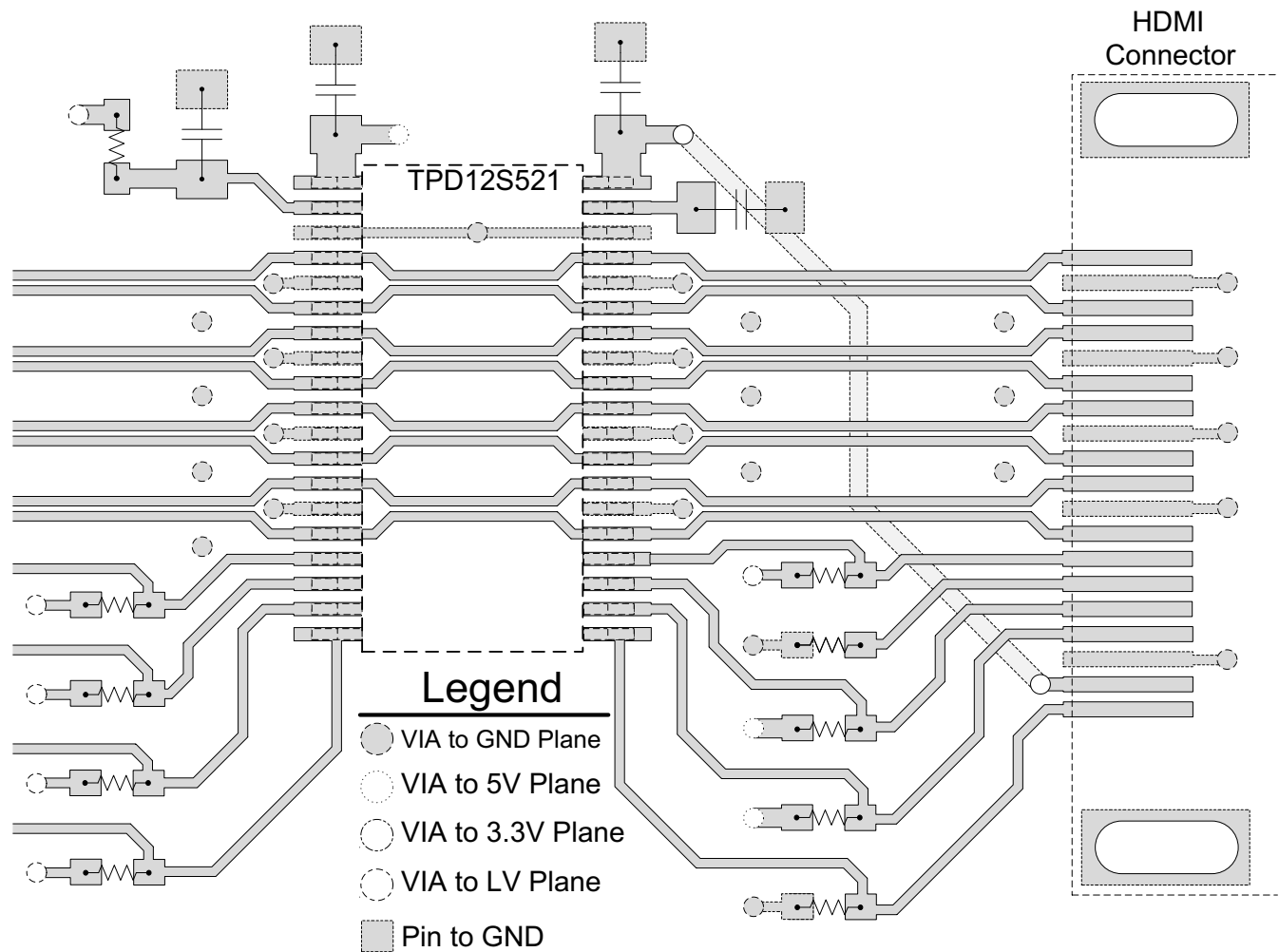

Use external and internal ground planes and stitch them together with VIAs as close to the GND pins of TPD12S521 as possible. This allows for a low impedance path to ground so that the device can properly dissipate an ESD event.

12 Device and Documentation Support

12.1 Trademarks

All trademarks are the property of their respective owners.

12.2 Electrostatic Discharge Caution



This integrated circuit can be damaged by ESD. Texas Instruments recommends that all integrated circuits be handled with appropriate precautions. Failure to observe proper handling and installation procedures can cause damage.

ESD damage can range from subtle performance degradation to complete device failure. Precision integrated circuits may be more susceptible to damage because very small parametric changes could cause the device not to meet its published specifications.

12.3 Glossary

[SLYZ022](#) — *TI Glossary*.

This glossary lists and explains terms, acronyms, and definitions.

13 Mechanical, Packaging, and Orderable Information

The following pages include mechanical packaging and orderable information. This information is the most current data available for the designated devices. This data is subject to change without notice and revision of this document. For browser-based versions of this data sheet, refer to the left-hand navigation.

PACKAGING INFORMATION

Orderable Device	Status (1)	Package Type	Package Drawing	Pins	Package Qty	Eco Plan (2)	Lead/Ball Finish (6)	MSL Peak Temp (3)	Op Temp (°C)	Device Marking (4/5)	Samples
TPD12S521DBTR	ACTIVE	TSSOP	DBT	38	2000	Green (RoHS & no Sb/Br)	CU NIPDAU	Level-2-260C-1 YEAR	-40 to 85	PN521	Samples
TPD12S521DBTRG4	ACTIVE	TSSOP	DBT	38	2000	Green (RoHS & no Sb/Br)	CU NIPDAU	Level-2-260C-1 YEAR	-40 to 85	PN521	Samples

(1) The marketing status values are defined as follows:

ACTIVE: Product device recommended for new designs.

LIFEBUY: TI has announced that the device will be discontinued, and a lifetime-buy period is in effect.

NRND: Not recommended for new designs. Device is in production to support existing customers, but TI does not recommend using this part in a new design.

PREVIEW: Device has been announced but is not in production. Samples may or may not be available.

OBsolete: TI has discontinued the production of the device.

(2) Eco Plan - The planned eco-friendly classification: Pb-Free (RoHS), Pb-Free (RoHS Exempt), or Green (RoHS & no Sb/Br) - please check <http://www.ti.com/productcontent> for the latest availability information and additional product content details.

TBD: The Pb-Free/Green conversion plan has not been defined.

Pb-Free (RoHS): TI's terms "Lead-Free" or "Pb-Free" mean semiconductor products that are compatible with the current RoHS requirements for all 6 substances, including the requirement that lead not exceed 0.1% by weight in homogeneous materials. Where designed to be soldered at high temperatures, TI Pb-Free products are suitable for use in specified lead-free processes.

Pb-Free (RoHS Exempt): This component has a RoHS exemption for either 1) lead-based flip-chip solder bumps used between the die and package, or 2) lead-based die adhesive used between the die and leadframe. The component is otherwise considered Pb-Free (RoHS compatible) as defined above.

Green (RoHS & no Sb/Br): TI defines "Green" to mean Pb-Free (RoHS compatible), and free of Bromine (Br) and Antimony (Sb) based flame retardants (Br or Sb do not exceed 0.1% by weight in homogeneous material)

(3) MSL, Peak Temp. - The Moisture Sensitivity Level rating according to the JEDEC industry standard classifications, and peak solder temperature.

(4) There may be additional marking, which relates to the logo, the lot trace code information, or the environmental category on the device.

(5) Multiple Device Markings will be inside parentheses. Only one Device Marking contained in parentheses and separated by a "~" will appear on a device. If a line is indented then it is a continuation of the previous line and the two combined represent the entire Device Marking for that device.

(6) Lead/Ball Finish - Orderable Devices may have multiple material finish options. Finish options are separated by a vertical ruled line. Lead/Ball Finish values may wrap to two lines if the finish value exceeds the maximum column width.

Important Information and Disclaimer: The information provided on this page represents TI's knowledge and belief as of the date that it is provided. TI bases its knowledge and belief on information provided by third parties, and makes no representation or warranty as to the accuracy of such information. Efforts are underway to better integrate information from third parties. TI has taken and continues to take reasonable steps to provide representative and accurate information but may not have conducted destructive testing or chemical analysis on incoming materials and chemicals. TI and TI suppliers consider certain information to be proprietary, and thus CAS numbers and other limited information may not be available for release.

In no event shall TI's liability arising out of such information exceed the total purchase price of the TI part(s) at issue in this document sold by TI to Customer on an annual basis.

TAPE AND REEL INFORMATION



QUADRANT ASSIGNMENTS FOR PIN 1 ORIENTATION IN TAPE



*All dimensions are nominal

Device	Package Type	Package Drawing	Pins	SPQ	Reel Diameter (mm)	Reel Width W1 (mm)	A0 (mm)	B0 (mm)	K0 (mm)	P1 (mm)	W (mm)	Pin1 Quadrant
TPD12S521DBTR	TSSOP	DBT	38	2000	330.0	16.4	6.9	10.2	1.8	12.0	16.0	Q1

TAPE AND REEL BOX DIMENSIONS



*All dimensions are nominal

Device	Package Type	Package Drawing	Pins	SPQ	Length (mm)	Width (mm)	Height (mm)
TPD12S521DBTR	TSSOP	DBT	38	2000	367.0	367.0	38.0

MECHANICAL DATA

DBT (R-PDSO-G38)

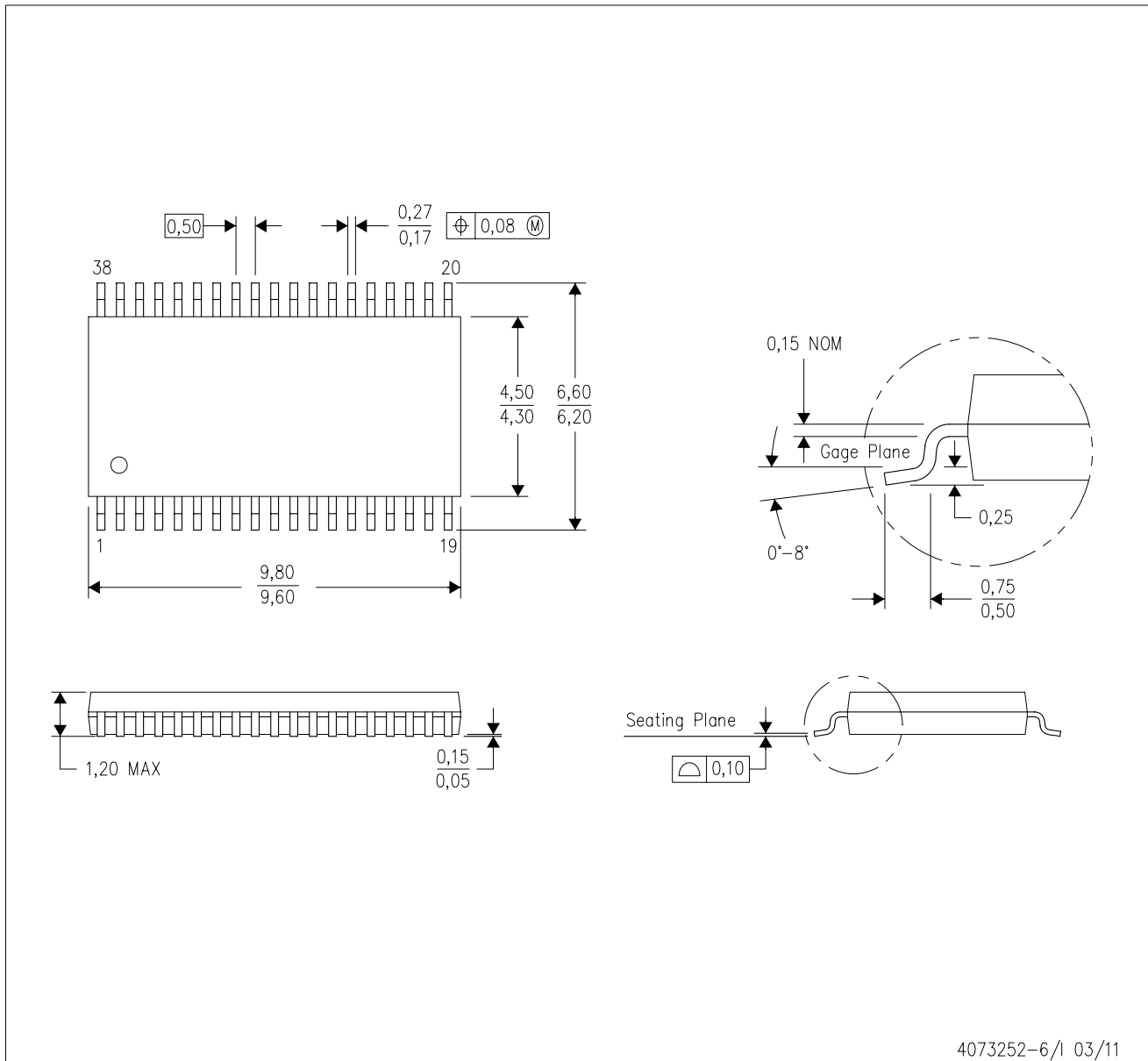
PLASTIC SMALL OUTLINE



- NOTES:
- All linear dimensions are in millimeters. Dimensioning and tolerancing per ASME Y14.5M-1994.
 - This drawing is subject to change without notice.
 - Body dimensions do not include mold flash or protrusion.
 - Falls within JEDEC MO-153.

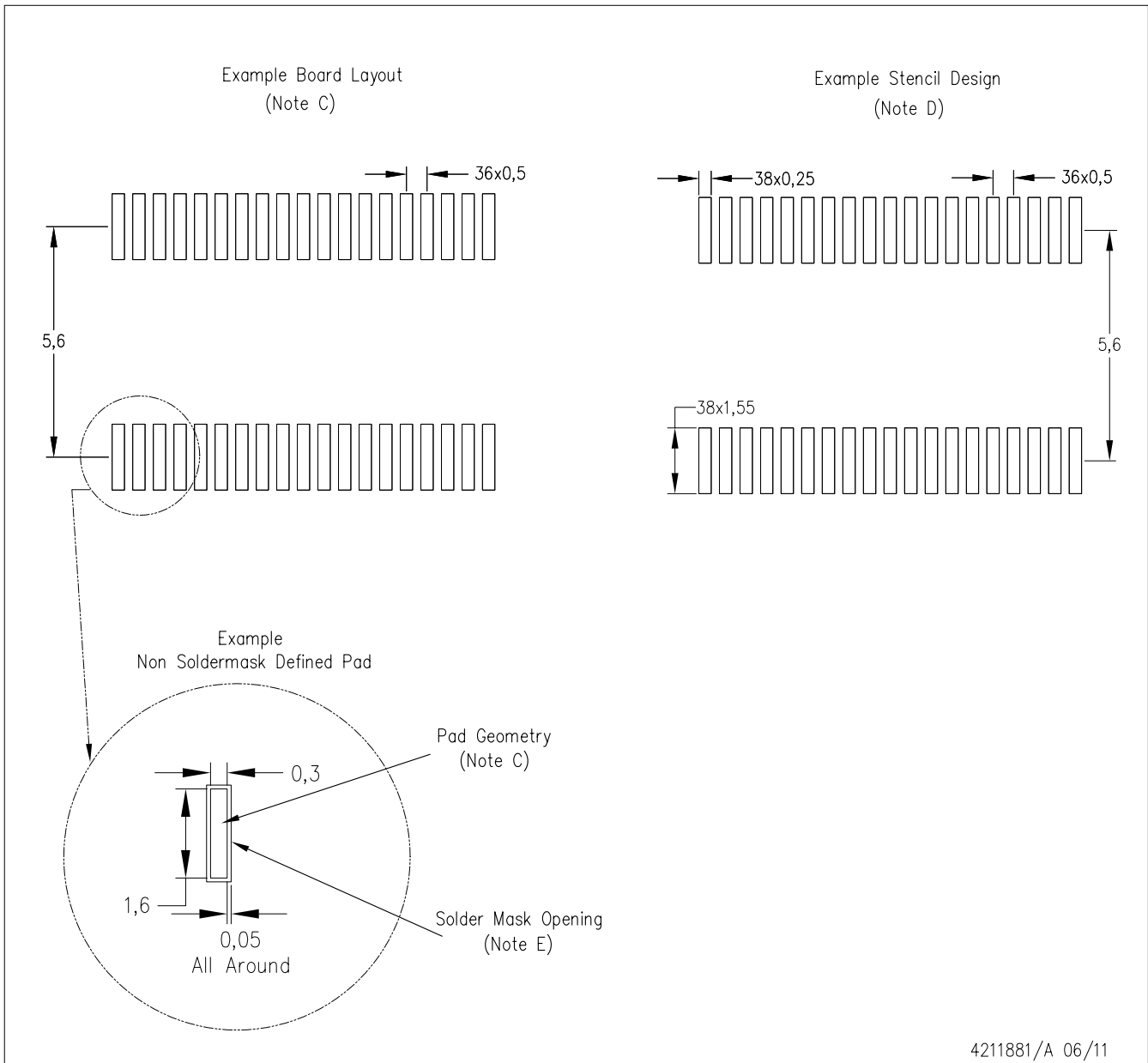

- NOTES:
- A. All linear dimensions are in millimeters.
 - B. This drawing is subject to change without notice.
 - C. Publication IPC-7351 is recommended for alternate designs.
 - D. Laser cutting apertures with trapezoidal walls and also rounding corners will offer better paste release. Customers should contact their board assembly site for stencil design recommendations. Refer to IPC-7525.
 - E. Customers should contact their board fabrication site for solder mask tolerances between and around signal pads.

IMPORTANT NOTICE

Texas Instruments Incorporated and its subsidiaries (TI) reserve the right to make corrections, enhancements, improvements and other changes to its semiconductor products and services per JESD46, latest issue, and to discontinue any product or service per JESD48, latest issue. Buyers should obtain the latest relevant information before placing orders and should verify that such information is current and complete. All semiconductor products (also referred to herein as "components") are sold subject to TI's terms and conditions of sale supplied at the time of order acknowledgment.

TI warrants performance of its components to the specifications applicable at the time of sale, in accordance with the warranty in TI's terms and conditions of sale of semiconductor products. Testing and other quality control techniques are used to the extent TI deems necessary to support this warranty. Except where mandated by applicable law, testing of all parameters of each component is not necessarily performed.

TI assumes no liability for applications assistance or the design of Buyers' products. Buyers are responsible for their products and applications using TI components. To minimize the risks associated with Buyers' products and applications, Buyers should provide adequate design and operating safeguards.

TI does not warrant or represent that any license, either express or implied, is granted under any patent right, copyright, mask work right, or other intellectual property right relating to any combination, machine, or process in which TI components or services are used. Information published by TI regarding third-party products or services does not constitute a license to use such products or services or a warranty or endorsement thereof. Use of such information may require a license from a third party under the patents or other intellectual property of the third party, or a license from TI under the patents or other intellectual property of TI.

Reproduction of significant portions of TI information in TI data books or data sheets is permissible only if reproduction is without alteration and is accompanied by all associated warranties, conditions, limitations, and notices. TI is not responsible or liable for such altered documentation. Information of third parties may be subject to additional restrictions.

Resale of TI components or services with statements different from or beyond the parameters stated by TI for that component or service voids all express and any implied warranties for the associated TI component or service and is an unfair and deceptive business practice. TI is not responsible or liable for any such statements.

Buyer acknowledges and agrees that it is solely responsible for compliance with all legal, regulatory and safety-related requirements concerning its products, and any use of TI components in its applications, notwithstanding any applications-related information or support that may be provided by TI. Buyer represents and agrees that it has all the necessary expertise to create and implement safeguards which anticipate dangerous consequences of failures, monitor failures and their consequences, lessen the likelihood of failures that might cause harm and take appropriate remedial actions. Buyer will fully indemnify TI and its representatives against any damages arising out of the use of any TI components in safety-critical applications.

In some cases, TI components may be promoted specifically to facilitate safety-related applications. With such components, TI's goal is to help enable customers to design and create their own end-product solutions that meet applicable functional safety standards and requirements. Nonetheless, such components are subject to these terms.

No TI components are authorized for use in FDA Class III (or similar life-critical medical equipment) unless authorized officers of the parties have executed a special agreement specifically governing such use.

Only those TI components which TI has specifically designated as military grade or "enhanced plastic" are designed and intended for use in military/aerospace applications or environments. Buyer acknowledges and agrees that any military or aerospace use of TI components which have **not** been so designated is solely at the Buyer's risk, and that Buyer is solely responsible for compliance with all legal and regulatory requirements in connection with such use.

TI has specifically designated certain components as meeting ISO/TS16949 requirements, mainly for automotive use. In any case of use of non-designated products, TI will not be responsible for any failure to meet ISO/TS16949.

Products

Audio	www.ti.com/audio
Amplifiers	amplifier.ti.com
Data Converters	dataconverter.ti.com
DLP® Products	www.dlp.com
DSP	dsp.ti.com
Clocks and Timers	www.ti.com/clocks
Interface	interface.ti.com
Logic	logic.ti.com
Power Mgmt	power.ti.com
Microcontrollers	microcontroller.ti.com
RFID	www.ti-rfid.com
OMAP Applications Processors	www.ti.com/omap
Wireless Connectivity	www.ti.com/wirelessconnectivity

Applications

Automotive and Transportation	www.ti.com/automotive
Communications and Telecom	www.ti.com/communications
Computers and Peripherals	www.ti.com/computers
Consumer Electronics	www.ti.com/consumer-apps
Energy and Lighting	www.ti.com/energy
Industrial	www.ti.com/industrial
Medical	www.ti.com/medical
Security	www.ti.com/security
Space, Avionics and Defense	www.ti.com/space-avionics-defense
Video and Imaging	www.ti.com/video

TI E2E Community

e2e.ti.com