

ALUMINUM ELECTROLYTIC CAPACITORS

GU Snap-in Terminal Type, 105°C Standard series



Anti-Solvent Feature (Through 100V only)

- Withstanding 3000 hours application of rated ripple current at 105°C.
- Compliant to the RoHS directive (2011/65/EU).

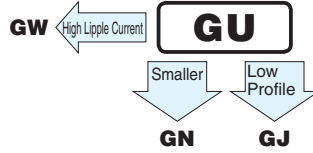
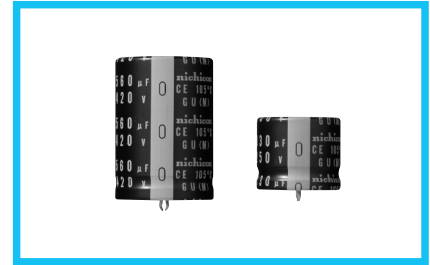

Specifications

Item	Performance Characteristics									
Category Temperature Range	- 40 to + 105°C (16 to 250V) , - 25 to +105°C (315 to 450V)									
Rated Voltage Range	16 to 450V									
Rated Capacitance Range	47 to 47000μF									
Capacitance Tolerance	±20% at 120Hz, 20°C									
Leakage Current	$I \leq 3 \cdot \sqrt{C \cdot V}$ (μA) (After 5 minutes' application of rated voltage) [C : Rated Capacitance (μF) V : Voltage (V)]									
Tangent of loss angle (tan δ)	Measurement frequency : 120Hz at 20°C									
	Rated voltage(V)	16	25	35	50	63	80·100	160 to 420	450	
	tan δ (MAX.)	0.50	0.40	0.35	0.30	0.25	0.20	0.15	0.20	
Stability at Low Temperature	Measurement frequency : 120Hz									
	Rated voltage (V)		16 to 100		160 to 250		315 to 450			
	Impedance ratio	Z - 25°C/Z+20°C	4		3		8			
	ZT/Z20 (MAX.)	Z - 40°C/Z+20°C	20		12		—			
Endurance	The specifications listed at right shall be met when the capacitors are restored to 20°C after D.C. bias plus rated ripple current is applied for 3000 hours at 105°C, the peak voltage shall not exceed the rated voltage.						Capacitance change		Within ±20% of the initial capacitance value	
							tan δ		200% or less than the initial specified value	
							Leakage current		Less than or equal to the initial specified value	
Shelf Life	After storing the capacitors under no load at 105°C for 1000 hours and then performing voltage treatment based on JIS C 5101-4 clause 4.1 at 20°C, they shall meet the characteristic requirements listed at right.						Capacitance change		Within ±15% of the initial capacitance value	
							tan δ		150% or less than the initial specified value	
							Leakage current		Less than or equal to the initial specified value	
Marking	Printed with white color letter on black sleeve.									

Drawing

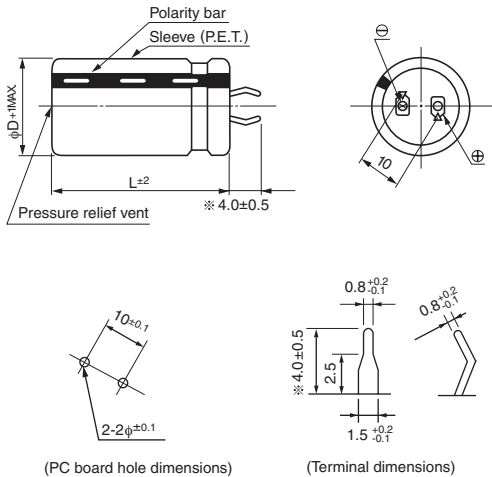

* The other terminal is also available upon request. Please refer page 326 for schematic of dimensions.

Type numbering system (Example : 200V 680μF)

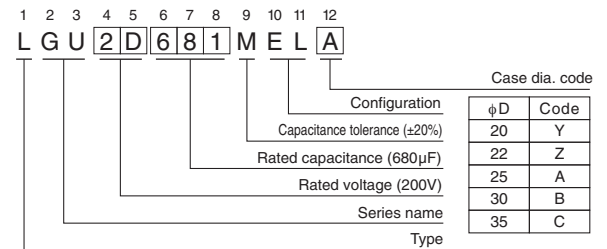

Frequency coefficient of rated ripple current

Frequency (Hz)	50	60	120	300	1k	10k	50k or more
Coeff.	16 to 100V	0.88	0.90	1.00	1.07	1.15	1.15
	160 to 250V	0.81	0.85	1.00	1.17	1.32	1.45
	315 to 450V	0.77	0.82	1.00	1.16	1.30	1.41

Minimum order quantity : 50pcs.

- Dimension table in next page.



■ Dimensions

16V (1C)				
Cap. (μF)	Size φD×L(mm)	Rated ripple (mA)	Leakage Current (mA)	Code
6800	22 × 25	1750	0.98	LGU1C682MELZ
8200	22 × 30	2000	1.08	LGU1C822MELZ
10000	22 × 30	2100	1.20	LGU1C103MELZ
	25 × 25	2050	1.20	LGU1C103MELA
12000	22 × 35	2310	1.31	LGU1C123MELZ
	25 × 30	2300	1.31	LGU1C123MELA
	30 × 25	2380	1.31	LGU1C123MELB
15000	22 × 40	2680	1.46	LGU1C153MELZ
	25 × 35	2680	1.46	LGU1C153MELA
	30 × 30	2570	1.46	LGU1C153MELB
18000	22 × 45	2980	1.60	LGU1C183MELZ
	25 × 40	3160	1.60	LGU1C183MELA
	30 × 30	3000	1.60	LGU1C183MELB
22000	25 × 45	3400	1.77	LGU1C223MELA
	30 × 35	3390	1.77	LGU1C223MELB
	35 × 30	3250	1.77	LGU1C223MELC
27000	25 × 50	3850	1.97	LGU1C273MELA
	30 × 40	3830	1.97	LGU1C273MELB
	35 × 30	3740	1.97	LGU1C273MELC
33000	30 × 45	4300	2.17	LGU1C333MELB
	35 × 35	4270	2.17	LGU1C333MELC
39000	30 × 50	4810	2.36	LGU1C393MELB
	35 × 40	4800	2.36	LGU1C393MELC
47000	35 × 45	5530	2.60	LGU1C473MELC

25V (1E)				
Cap. (μF)	Size φD×L(mm)	Rated ripple (mA)	Leakage Current (mA)	Code
4700	22 × 25	1610	1.02	LGU1E472MELZ
5600	22 × 30	1800	1.12	LGU1E562MELZ
6800	22 × 30	1910	1.23	LGU1E682MELZ
	25 × 25	1910	1.23	LGU1E682MELA
8200	22 × 35	2140	1.35	LGU1E822MELZ
	25 × 30	2340	1.35	LGU1E822MELA
	30 × 25	2250	1.35	LGU1E822MELB
10000	22 × 40	2650	1.50	LGU1E103MELZ
	25 × 35	2610	1.50	LGU1E103MELA
	30 × 30	2610	1.50	LGU1E103MELB
12000	22 × 45	2690	1.64	LGU1E123MELZ
	25 × 40	2810	1.64	LGU1E123MELA
	30 × 30	2740	1.64	LGU1E123MELB
15000	25 × 45	3270	1.83	LGU1E153MELA
	30 × 35	3130	1.83	LGU1E153MELB
	35 × 30	3260	1.83	LGU1E153MELC
18000	25 × 50	3540	2.01	LGU1E183MELA
	30 × 40	3560	2.01	LGU1E183MELB
	35 × 35	3840	2.01	LGU1E183MELC
22000	30 × 45	4240	2.22	LGU1E223MELB
	35 × 35	3960	2.22	LGU1E223MELC
27000	35 × 45	4750	2.46	LGU1E273MELC
33000	35 × 50	5500	2.72	LGU1E333MELC

35V (1V)				
Cap. (μF)	Size φD×L(mm)	Rated ripple (mA)	Leakage Current (mA)	Code
3300	22 × 25	1450	1.01	LGU1V332MELZ
3900	22 × 30	1690	1.10	LGU1V392MELZ
4700	22 × 35	2020	1.21	LGU1V472MELZ
	25 × 25	1780	1.21	LGU1V472MELA
5600	22 × 35	2130	1.32	LGU1V562MELZ
	25 × 30	2040	1.32	LGU1V562MELA
	30 × 25	2120	1.32	LGU1V562MELB
6800	22 × 40	2410	1.46	LGU1V682MELZ
	25 × 35	2310	1.46	LGU1V682MELA
	30 × 25	2310	1.46	LGU1V682MELB
8200	22 × 50	2850	1.60	LGU1V822MELZ
	25 × 40	2730	1.60	LGU1V822MELA
	30 × 30	2750	1.60	LGU1V822MELB
10000	25 × 45	3050	1.77	LGU1V103MELA
	30 × 35	3050	1.77	LGU1V103MELB
	25 × 50	3370	1.94	LGU1V123MELA
12000	30 × 40	3280	1.94	LGU1V123MELB
	35 × 30	3200	1.94	LGU1V123MELC
	30 × 45	3740	2.17	LGU1V153MELB
15000	35 × 35	3690	2.17	LGU1V153MELC
	18000	35 × 40	4370	2.38
22000	35 × 50	4920	2.63	LGU1V223MELC

50V (1H)				
Cap. (μF)	Size φD×L(mm)	Rated ripple (mA)	Leakage Current (mA)	Code
1800	22 × 25	1340	0.90	LGU1H182MELZ
2700	22 × 30	1700	1.10	LGU1H272MELZ
	25 × 25	1700	1.10	LGU1H272MELA
3300	22 × 35	1980	1.21	LGU1H332MELZ
	25 × 30	2000	1.21	LGU1H332MELA
3900	22 × 40	2250	1.32	LGU1H392MELZ
	25 × 30	2280	1.32	LGU1H392MELA
	30 × 25	2220	1.32	LGU1H392MELB
4700	22 × 45	2560	1.45	LGU1H472MELZ
	25 × 35	2610	1.45	LGU1H472MELA
	30 × 30	2580	1.45	LGU1H472MELB
5600	22 × 50	2890	1.58	LGU1H562MELZ
	25 × 40	2810	1.58	LGU1H562MELA
	30 × 30	2950	1.58	LGU1H562MELB
6800	25 × 45	3370	1.74	LGU1H682MELA
	30 × 35	3390	1.74	LGU1H682MELB
	35 × 30	3310	1.74	LGU1H682MELC
8200	30 × 40	3710	1.92	LGU1H822MELB
	35 × 35	3660	1.92	LGU1H822MELC
10000	30 × 50	4090	2.12	LGU1H103MELB
	35 × 40	4070	2.12	LGU1H103MELC
12000	35 × 45	4560	2.32	LGU1H123MELC
15000	35 × 50	4770	2.59	LGU1H153MELC

Rated ripple current (mA_{rms}) at 105°C 120Hz



■ Dimensions

63V (1J)				
Cap. (μF)	Size φD×L(mm)	Rated ripple (mA)	Leakage Current (mA)	Code
1200	22 × 25	1250	0.82	LGU1J122MELZ
1500	22 × 30	1470	0.92	LGU1J152MELZ
	25 × 25	1440	0.92	LGU1J152MELA
1800	22 × 30	1580	1.01	LGU1J182MELZ
	25 × 25	1520	1.01	LGU1J182MELA
2200	22 × 35	1820	1.11	LGU1J222MELZ
	25 × 30	1750	1.11	LGU1J222MELA
2700	22 × 40	2070	1.23	LGU1J272MELZ
	25 × 35	2110	1.23	LGU1J272MELA
	30 × 25	1930	1.23	LGU1J272MELB
3300	22 × 45	2330	1.36	LGU1J332MELZ
	25 × 35	2270	1.36	LGU1J332MELA
	30 × 30	2240	1.36	LGU1J332MELB
3900	25 × 40	2540	1.48	LGU1J392MELA
	30 × 35	2550	1.48	LGU1J392MELB
4700	25 × 50	2970	1.63	LGU1J472MELA
	30 × 40	2900	1.63	LGU1J472MELB
	35 × 30	2830	1.63	LGU1J472MELC
5600	30 × 40	3280	1.78	LGU1J562MELB
	35 × 35	3240	1.78	LGU1J562MELC
6800	30 × 50	3730	1.96	LGU1J682MELB
	35 × 40	3710	1.96	LGU1J682MELC
8200	35 × 45	4160	2.15	LGU1J822MELC
10000	35 × 50	4690	2.38	LGU1J103MELC

80V (1K)				
Cap. (μF)	Size φD×L(mm)	Rated ripple (mA)	Leakage Current (mA)	Code
820	22 × 25	1110	0.76	LGU1K821MELZ
1000	22 × 25	1290	0.84	LGU1K102MELZ
1200	22 × 30	1440	0.92	LGU1K122MELZ
	25 × 25	1390	0.92	LGU1K122MELA
1500	22 × 30	1610	1.03	LGU1K152MELZ
	25 × 25	1620	1.03	LGU1K152MELA
1800	22 × 35	1830	1.13	LGU1K182MELZ
	25 × 30	1860	1.13	LGU1K182MELA
	30 × 25	1810	1.13	LGU1K182MELB
2200	22 × 40	2090	1.25	LGU1K222MELZ
	25 × 35	2010	1.25	LGU1K222MELA
	30 × 25	2100	1.25	LGU1K222MELB
2700	25 × 40	2430	1.39	LGU1K272MELA
	30 × 30	2430	1.39	LGU1K272MELB
3300	25 × 45	2760	1.54	LGU1K332MELA
	30 × 35	2780	1.54	LGU1K332MELB
	35 × 30	2710	1.54	LGU1K332MELC
3900	25 × 50	2920	1.67	LGU1K392MELA
	30 × 40	3120	1.67	LGU1K392MELB
	35 × 30	3070	1.67	LGU1K392MELC
4700	30 × 45	3520	1.83	LGU1K472MELB
	35 × 35	3500	1.83	LGU1K472MELC
5600	30 × 50	3800	2.00	LGU1K562MELB
	35 × 40	3870	2.00	LGU1K562MELC
6800	35 × 45	4190	2.21	LGU1K682MELC

100V (2A)				
Cap. (μF)	Size φD×L(mm)	Rated ripple (mA)	Leakage Current (mA)	Code
560	22 × 25	1070	0.70	LGU2A561MELZ
820	22 × 30	1350	0.85	LGU2A821MELZ
	25 × 25	1350	0.85	LGU2A821MELA
1000	22 × 30	1540	0.94	LGU2A102MELZ
	25 × 30	1560	0.94	LGU2A102MELA
1200	22 × 40	1740	1.03	LGU2A122MELZ
	25 × 30	1760	1.03	LGU2A122MELA
	30 × 25	1710	1.03	LGU2A122MELB
1500	22 × 45	1990	1.16	LGU2A152MELZ
	25 × 35	2030	1.16	LGU2A152MELA
	30 × 30	2000	1.16	LGU2A152MELB
1800	25 × 40	2280	1.27	LGU2A182MELA
	30 × 35	2270	1.27	LGU2A182MELB
2200	25 × 50	2570	1.40	LGU2A222MELA
	30 × 35	2590	1.40	LGU2A222MELB
	35 × 30	2520	1.40	LGU2A222MELC
2700	30 × 45	2940	1.55	LGU2A272MELB
	35 × 35	2900	1.55	LGU2A272MELC
3300	30 × 50	3320	1.72	LGU2A332MELB
	35 × 40	3310	1.72	LGU2A332MELC
3900	35 × 45	3690	1.87	LGU2A392MELC
4700	35 × 50	4140	2.05	LGU2A472MELC

160V (2C)				
Cap. (μF)	Size φD×L(mm)	Rated ripple (mA)	Leakage Current (mA)	Code
270	20 × 25	1100	0.62	LGU2C271MELY
330	20 × 30	1200	0.68	LGU2C331MELY
390	20 × 30	1300	0.74	LGU2C391MELY
	22 × 25	1300	0.74	LGU2C391MELZ
470	20 × 35	1340	0.82	LGU2C471MELY
	22 × 30	1550	0.82	LGU2C471MELZ
	25 × 25	1550	0.82	LGU2C471MELA
560	20 × 40	1500	0.89	LGU2C561MELY
	22 × 35	1670	0.89	LGU2C561MELZ
	25 × 30	1670	0.89	LGU2C561MELA
	30 × 25	1670	0.89	LGU2C561MELB
680	20 × 45	1700	0.98	LGU2C681MELY
	22 × 40	1820	0.98	LGU2C681MELZ
	25 × 30	1820	0.98	LGU2C681MELA
	30 × 25	1820	0.98	LGU2C681MELB
820	22 × 45	2040	1.08	LGU2C821MELZ
	25 × 35	2040	1.08	LGU2C821MELA
	30 × 30	2040	1.08	LGU2C821MELB
	35 × 25	2040	1.08	LGU2C821MELC
1000	22 × 50	2250	1.20	LGU2C102MELZ
	25 × 40	2250	1.20	LGU2C102MELA
	30 × 30	2250	1.20	LGU2C102MELB
	35 × 25	2250	1.20	LGU2C102MELC
1200	25 × 45	2490	1.31	LGU2C122MELA
	30 × 35	2490	1.31	LGU2C122MELB
	35 × 30	2490	1.31	LGU2C122MELC
1500	30 × 40	2840	1.46	LGU2C152MELB
	35 × 30	2840	1.46	LGU2C152MELC
1800	30 × 45	3320	1.60	LGU2C182MELB
	35 × 35	3000	1.60	LGU2C182MELC
2200	35 × 45	3500	1.77	LGU2C222MELC
2700	35 × 50	4000	1.97	LGU2C272MELC

Rated ripple current (mA_{rms}) at 105°C 120Hz



■ Dimensions

180V (2Z)				
Cap.(μF)	Size φD×L(mm)	Rated ripple (mA)	Leakage Current (mA)	Code
220	20 × 25	1000	0.59	LGU2Z221MELY
270	20 × 30	1100	0.66	LGU2Z271MELY
330	20 × 30	1200	0.73	LGU2Z331MELY
	22 × 25	1200	0.73	LGU2Z331MELZ
390	20 × 35	1300	0.79	LGU2Z391MELY
	22 × 30	1350	0.79	LGU2Z391MELZ
	25 × 25	1350	0.79	LGU2Z391MELA
470	20 × 40	1400	0.87	LGU2Z471MELY
	22 × 35	1500	0.87	LGU2Z471MELZ
	25 × 30	1500	0.87	LGU2Z471MELA
	30 × 25	1500	0.87	LGU2Z471MELB
560	20 × 45	1550	0.95	LGU2Z561MELY
	22 × 40	1670	0.95	LGU2Z561MELZ
	25 × 30	1670	0.95	LGU2Z561MELA
	30 × 25	1670	0.95	LGU2Z561MELB
680	22 × 45	1780	1.04	LGU2Z681MELZ
	25 × 35	1780	1.04	LGU2Z681MELA
	30 × 30	1780	1.04	LGU2Z681MELB
	35 × 25	1780	1.04	LGU2Z681MELC
820	22 × 50	2040	1.15	LGU2Z821MELZ
	25 × 40	2040	1.15	LGU2Z821MELA
	30 × 30	2040	1.15	LGU2Z821MELB
	35 × 25	2040	1.15	LGU2Z821MELC
1000	25 × 45	2300	1.27	LGU2Z102MELA
	30 × 35	2300	1.27	LGU2Z102MELB
	35 × 30	2300	1.27	LGU2Z102MELC
1200	25 × 50	2550	1.39	LGU2Z122MELA
	30 × 40	2550	1.39	LGU2Z122MELB
	35 × 30	2550	1.39	LGU2Z122MELC
1500	30 × 45	2900	1.55	LGU2Z152MELB
	35 × 35	2900	1.55	LGU2Z152MELC
1800	35 × 45	3300	1.70	LGU2Z182MELC
2200	35 × 50	3650	1.88	LGU2Z222MELC

200V (2D)				
Cap.(μF)	Size φD×L(mm)	Rated ripple (mA)	Leakage Current (mA)	Code
220	20 × 25	1000	0.62	LGU2D221MELY
270	20 × 30	1100	0.69	LGU2D271MELY
	22 × 25	1100	0.69	LGU2D271MELZ
330	20 × 35	1200	0.77	LGU2D331MELY
	22 × 30	1250	0.77	LGU2D331MELZ
	25 × 25	1250	0.77	LGU2D331MELA
390	20 × 40	1310	0.83	LGU2D391MELY
	22 × 30	1350	0.83	LGU2D391MELZ
	25 × 25	1350	0.83	LGU2D391MELA
470	20 × 45	1450	0.91	LGU2D471MELY
	22 × 35	1500	0.91	LGU2D471MELZ
	25 × 30	1500	0.91	LGU2D471MELA
	30 × 25	1500	0.91	LGU2D471MELB
560	20 × 50	1580	1.00	LGU2D561MELY
	22 × 40	1670	1.00	LGU2D561MELZ
	25 × 30	1670	1.00	LGU2D561MELA
	30 × 25	1670	1.00	LGU2D561MELB
680	22 × 45	1780	1.10	LGU2D681MELZ
	25 × 35	1780	1.10	LGU2D681MELA
	30 × 30	1780	1.10	LGU2D681MELB
	35 × 25	1780	1.10	LGU2D681MELC
820	25 × 45	2040	1.21	LGU2D821MELA
	30 × 30	2040	1.21	LGU2D821MELB
	35 × 25	2040	1.21	LGU2D821MELC
1000	25 × 50	2300	1.34	LGU2D102MELA
	30 × 35	2300	1.34	LGU2D102MELB
	35 × 30	2300	1.34	LGU2D102MELC
1200	30 × 40	2650	1.46	LGU2D122MELB
	35 × 35	2650	1.46	LGU2D122MELC
1500	30 × 50	3080	1.64	LGU2D152MELB
	35 × 40	3080	1.64	LGU2D152MELC
1800	35 × 45	3480	1.80	LGU2D182MELC
2200	35 × 50	3780	1.98	LGU2D222MELC

220V (2P)				
Cap.(μF)	Size φD×L(mm)	Rated ripple (mA)	Leakage Current (mA)	Code
180	20 × 25	900	0.59	LGU2P181MELY
220	20 × 30	1000	0.66	LGU2P221MELY
	22 × 25	1000	0.66	LGU2P221MELZ
270	20 × 35	1150	0.73	LGU2P271MELY
	22 × 30	1150	0.73	LGU2P271MELZ
330	20 × 40	1250	0.80	LGU2P331MELY
	22 × 35	1250	0.80	LGU2P331MELZ
	25 × 25	1250	0.80	LGU2P331MELA
390	20 × 45	1400	0.87	LGU2P391MELY
	22 × 35	1400	0.87	LGU2P391MELZ
	25 × 30	1400	0.87	LGU2P391MELA
470	20 × 50	1450	0.96	LGU2P471MELY
	22 × 40	1450	0.96	LGU2P471MELZ
	25 × 35	1450	0.96	LGU2P471MELA
	30 × 25	1450	0.96	LGU2P471MELB
560	22 × 45	1700	1.05	LGU2P561MELZ
	25 × 40	1700	1.05	LGU2P561MELA
	30 × 30	1700	1.05	LGU2P561MELB
680	25 × 45	1780	1.16	LGU2P681MELA
	30 × 35	1780	1.16	LGU2P681MELB
	35 × 25	1780	1.16	LGU2P681MELC
820	25 × 50	2100	1.27	LGU2P821MELA
	30 × 40	2100	1.27	LGU2P821MELB
	35 × 30	2100	1.27	LGU2P821MELC
1000	30 × 45	2400	1.40	LGU2P102MELB
	35 × 35	2400	1.40	LGU2P102MELC
1200	30 × 50	2600	1.54	LGU2P122MELB
	35 × 40	2600	1.54	LGU2P122MELC
1500	35 × 45	3000	1.72	LGU2P152MELC

250V (2E)				
Cap.(μF)	Size φD×L(mm)	Rated ripple (mA)	Leakage Current (mA)	Code
150	20 × 25	790	0.58	LGU2E151MELY
180	20 × 30	900	0.63	LGU2E181MELY
220	20 × 30	1000	0.70	LGU2E221MELY
	22 × 25	1000	0.70	LGU2E221MELZ
270	20 × 35	1100	0.77	LGU2E271MELY
	22 × 35	1180	0.77	LGU2E271MELZ
	25 × 25	1180	0.77	LGU2E271MELA
330	20 × 40	1200	0.86	LGU2E331MELY
	22 × 40	1300	0.86	LGU2E331MELZ
	25 × 30	1300	0.86	LGU2E331MELA
	30 × 25	1300	0.86	LGU2E331MELB
	20 × 50	1450	0.93	LGU2E391MELY
390	22 × 45	1490	0.93	LGU2E391MELZ
	25 × 35	1490	0.93	LGU2E391MELA
	30 × 25	1490	0.93	LGU2E391MELB
	22 × 50	1650	1.02	LGU2E471MELZ
470	25 × 40	1650	1.02	LGU2E471MELA
	30 × 30	1650	1.02	LGU2E471MELB
	35 × 25	1650	1.02	LGU2E471MELC
	25 × 45	1800	1.12	LGU2E561MELA
560	30 × 35	1800	1.12	LGU2E561MELB
	35 × 25	1800	1.12	LGU2E561MELC
	25 × 50	2000	1.23	LGU2E681MELA
680	30 × 40	2000	1.23	LGU2E681MELB
	35 × 30	2000	1.23	LGU2E681MELC
	30 × 45	2300	1.35	LGU2E821MELB
820	35 × 35	2300	1.35	LGU2E821MELC
	30 × 50	2470	1.50	LGU2E102MELB
1000	35 × 40	2470	1.50	LGU2E102MELC
	35 × 45	2600	1.64	LGU2E122MELC
1500	35 × 50	3000	1.83	LGU2E152MELC

Rated ripple current (mArms) at 105°C 120Hz



■ Dimensions

315V (2F)				
Cap.(μF)	Size φD×L(mm)	Rated ripple (mA)	Leakage Current (mA)	Code
82	20 × 25	640	0.48	LGU2F820MELY
100	20 × 30	690	0.53	LGU2F101MELY
120	20 × 30	750	0.58	LGU2F121MELY
	22 × 25	750	0.58	LGU2F121MELZ
150	20 × 35	820	0.65	LGU2F151MELY
	22 × 30	820	0.65	LGU2F151MELZ
	25 × 25	820	0.65	LGU2F151MELA
180	20 × 40	900	0.71	LGU2F181MELY
	22 × 35	920	0.71	LGU2F181MELZ
	25 × 25	920	0.71	LGU2F181MELA
220	20 × 50	1000	0.78	LGU2F221MELY
	22 × 40	1040	0.78	LGU2F221MELZ
	25 × 30	1040	0.78	LGU2F221MELA
	30 × 25	1040	0.78	LGU2F221MELB
270	22 × 45	1160	0.87	LGU2F271MELY
	25 × 35	1160	0.87	LGU2F271MELA
	30 × 25	1160	0.87	LGU2F271MELB
330	22 × 50	1330	0.96	LGU2F331MELZ
	25 × 40	1330	0.96	LGU2F331MELA
	30 × 30	1330	0.96	LGU2F331MELB
	35 × 25	1330	0.96	LGU2F331MELC
390	25 × 45	1470	1.05	LGU2F391MELA
	30 × 35	1470	1.05	LGU2F391MELB
	35 × 30	1470	1.05	LGU2F391MELC
470	25 × 50	1700	1.15	LGU2F471MELA
	30 × 40	1700	1.15	LGU2F471MELB
	35 × 30	1700	1.15	LGU2F471MELC
560	30 × 45	2050	1.26	LGU2F561MELB
	35 × 35	2050	1.26	LGU2F561MELC
680	30 × 50	2170	1.38	LGU2F681MELB
	35 × 40	2170	1.38	LGU2F681MELC
820	35 × 45	2200	1.52	LGU2F821MELC

400V (2G)				
Cap.(μF)	Size φD×L(mm)	Rated ripple (mA)	Leakage Current (mA)	Code
56	20 × 25	510	0.44	LGU2G560MELY
68	20 × 30	560	0.49	LGU2G680MELY
82	20 × 30	640	0.54	LGU2G820MELY
	22 × 25	640	0.54	LGU2G820MELZ
100	20 × 35	700	0.60	LGU2G101MELY
	22 × 30	700	0.60	LGU2G101MELZ
	25 × 25	700	0.60	LGU2G101MELA
120	20 × 40	750	0.65	LGU2G121MELY
	22 × 35	750	0.65	LGU2G121MELZ
	25 × 25	750	0.65	LGU2G121MELA
	20 × 45	830	0.73	LGU2G151MELY
150	22 × 40	880	0.73	LGU2G151MELZ
	25 × 30	880	0.73	LGU2G151MELA
	30 × 25	880	0.73	LGU2G151MELB
180	22 × 45	980	0.80	LGU2G181MELY
	25 × 35	980	0.80	LGU2G181MELZ
	30 × 30	980	0.80	LGU2G181MELB
	35 × 25	980	0.80	LGU2G181MELC
220	22 × 50	1100	0.88	LGU2G221MELY
	25 × 40	1100	0.88	LGU2G221MELA
	30 × 30	1100	0.88	LGU2G221MELB
	35 × 25	1100	0.88	LGU2G221MELC
270	25 × 45	1220	0.98	LGU2G271MELA
	30 × 35	1220	0.98	LGU2G271MELB
	35 × 30	1220	0.98	LGU2G271MELC
330	25 × 50	1440	1.08	LGU2G331MELA
	30 × 40	1440	1.08	LGU2G331MELB
	35 × 30	1440	1.08	LGU2G331MELC
390	30 × 45	1600	1.18	LGU2G391MELB
	35 × 35	1600	1.18	LGU2G391MELC
470	30 × 50	1900	1.30	LGU2G471MELB
	35 × 40	1900	1.30	LGU2G471MELC
560	35 × 45	2120	1.41	LGU2G561MELC

420V (W6)				
Cap.(μF)	Size φD×L(mm)	Rated ripple (mA)	Leakage Current (mA)	Code
56	20 × 25	510	0.46	LGUW6560MELY
68	20 × 30	560	0.50	LGUW6680MELY
82	20 × 35	640	0.55	LGUW6820MELY
	22 × 25	640	0.55	LGUW6820MELZ
100	20 × 35	700	0.61	LGUW6101MELY
	22 × 30	700	0.61	LGUW6101MELZ
	25 × 25	700	0.61	LGUW6101MELA
	20 × 40	750	0.67	LGUW6121MELY
120	22 × 35	750	0.67	LGUW6121MELZ
	25 × 30	750	0.67	LGUW6121MELA
	20 × 50	880	0.75	LGUW6151MELY
150	22 × 40	880	0.75	LGUW6151MELZ
	25 × 35	880	0.75	LGUW6151MELA
	30 × 25	880	0.75	LGUW6151MELB
	22 × 45	950	0.82	LGUW6181MELZ
180	25 × 35	950	0.82	LGUW6181MELA
	30 × 30	950	0.82	LGUW6181MELB
	22 × 50	1100	0.91	LGUW6221MELZ
220	25 × 45	1100	0.91	LGUW6221MELA
	30 × 35	1100	0.91	LGUW6221MELB
	35 × 25	1100	0.91	LGUW6221MELC
	25 × 50	1220	1.01	LGUW6271MELA
270	30 × 40	1220	1.01	LGUW6271MELB
	35 × 30	1220	1.01	LGUW6271MELC
	30 × 45	1450	1.11	LGUW6331MELB
330	35 × 35	1450	1.11	LGUW6331MELC
	30 × 50	1550	1.21	LGUW6391MELB
470	35 × 40	1550	1.21	LGUW6391MELC
	35 × 45	1900	1.33	LGUW6471MELC
560	35 × 50	2150	1.45	LGUW6561MELC

450V (2W)				
Cap.(μF)	Size φD×L(mm)	Rated ripple (mA)	Leakage Current (mA)	Code
47	20 × 25	390	0.43	LGU2W470MELY
56	20 × 30	510	0.47	LGU2W560MELY
68	20 × 35	560	0.52	LGU2W680MELY
	20 × 35	640	0.57	LGU2W820MELY
82	22 × 30	640	0.57	LGU2W820MELZ
	25 × 25	640	0.57	LGU2W820MELA
	20 × 45	690	0.63	LGU2W101MELY
	22 × 35	690	0.63	LGU2W101MELZ
100	25 × 30	690	0.63	LGU2W101MELA
	20 × 50	750	0.69	LGU2W121MELY
	22 × 40	800	0.69	LGU2W121MELZ
120	25 × 30	800	0.69	LGU2W121MELA
	30 × 25	800	0.69	LGU2W121MELB
	22 × 45	880	0.77	LGU2W151MELZ
	25 × 35	880	0.77	LGU2W151MELA
150	30 × 30	880	0.77	LGU2W151MELB
	22 × 50	1000	0.85	LGU2W181MELZ
	25 × 40	1000	0.85	LGU2W181MELA
180	30 × 30	1000	0.85	LGU2W181MELB
	25 × 45	1120	0.94	LGU2W221MELA
	30 × 35	1120	0.94	LGU2W221MELC
220	35 × 30	1120	0.94	LGU2W221MELC
	30 × 40	1280	1.04	LGU2W271MELB
	35 × 35	1280	1.04	LGU2W271MELC
270	30 × 50	1450	1.15	LGU2W331MELB
	35 × 40	1450	1.15	LGU2W331MELC
390	35 × 40	1500	1.25	LGU2W391MELC
470	35 × 50	1850	1.37	LGU2W471MELC

Rated ripple current (mArms) at 105°C 120Hz

Mouser Electronics

Authorized Distributor

Click to View Pricing, Inventory, Delivery & Lifecycle Information:

Nichicon:

[LGU1J222MELZ](#) [LGU2D152MELC](#) [LGU2W221MHLC](#) [LGU2W820MESA](#) [LGUW6221MELC](#) [LGU2D821MELB](#)
[LGU2G471MELB](#) [LGU1H103MELC](#) [LGU1H272MELZ](#) [LGU1H472MELZ](#) [LGU1H822MELB](#) [LGU2D102MELB](#)
[LGU2D681MELB](#) [LGU2E181MELENA](#) [LGU2G221MELB](#) [LGU2G221MELC](#) [LGU2G271MELA](#) [LGU2G560MELY](#)
[LGU2G820MELZ](#) [LGU2W101MELZ](#) [LGU2W181MELA](#) [LGU2W271MELB](#) [LGU2W271MELENA](#) [LGUW6151MELZ](#)
[LGU1H103MELB](#) [LGU1H272MELA](#) [LGU2W101MELA](#) [LGU1K392MHLC](#) [LGU2G121MELZ](#) [LGU2G391MELB](#)
[LGU2W151MELB](#) [LGU2W221MELB](#) [LGU2W221MELC](#) [LGU2W331MELC](#) [LGU2W391MELC](#) [LGU1K562MELC](#)
[LGU2G221MELZ](#) [LGU1K102MELZ](#) [LGU2W121MELZ](#) [LGU2W121MELB](#) [LGU2G331MHLA](#) [LGU2G331MHLB](#)
[LGUW6221MHLC](#) [LGU2F331MELB](#) [LGU2W470MHLY](#) [LGU2W271MHLB](#) [LGU2C561MHLB](#) [LGU2W820MELA](#)
[LGU2C182MHLC](#) [LGU2W181MHLA](#) [LGU2D681MHLA](#) [LGU2E821MHLC](#) [LGU1C103MELA](#) [LGU1C103MHLA](#)
[LGU1C223MELA](#) [LGU1C223MHLA](#) [LGU1H103MHLC](#) [LGU1H472MELB](#) [LGU1H472MHLZ](#) [LGU1H682MELC](#)
[LGU1H822MHLB](#) [LGU1J332MELA](#) [LGU1V103MELA](#) [LGU1V103MHLA](#) [LGU1V682MHLA](#) [LGU2D102MELC](#)
[LGU2D102MHLB](#) [LGU2D102MHLC](#) [LGU2D122MHLC](#) [LGU2D152MHLC](#) [LGU2D221MHLY](#) [LGU2D561MELA](#)
[LGU2D681MELA](#) [LGU2D681MHLB](#) [LGU2D821MHLB](#) [LGU2E181MHLENA](#) [LGU2E221MELY](#) [LGU2E221MELZ](#)
[LGU2E471MELB](#) [LGU2E681MELB](#) [LGU2G101MELA](#) [LGU2G101MELZ](#) [LGU2G101MHLA](#) [LGU2G121MDLA](#)
[LGU2G121MELA](#) [LGU2G121MHLA](#) [LGU2G151MELA](#) [LGU2G181MELB](#) [LGU2G221MHLB](#) [LGU2G221MHLC](#)
[LGU2G271MHLA](#) [LGU2G331MELB](#) [LGU2G331MELC](#) [LGU2G391MHLC](#) [LGU2G471MELC](#) [LGU2G560MHLY](#)
[LGU2G561MHLC](#) [LGU2W101MHLZ](#) [LGU2W471MELC](#) [LGU2W820MHSA](#)