

PART NUMBER	ITEM ① BCDY	ITEM ② CONTACT	ITEM ③ INSULATOR
142-D7D1-BB1	BRASS GOLD PL .00001 MIN OVER NICKEL PL .00005 MIN OVER COPPER PL .00005 MIN	BERYLLIUM COPPER GOLD PL .00005 MIN OVER NICKEL PL .00005 MIN OVER COPPER PL .00005 MIN	TEFLON
142-D7D1-BB6	BRASS NICKEL PL .0001 MIN OVER COPPER PL .00005 MIN OVER	BERYLLIUM COPPER GOLD PL .00003 MIN OVER NICKEL PL .00005 MIN OVER COPPER PL .00005 MIN	TEFLON

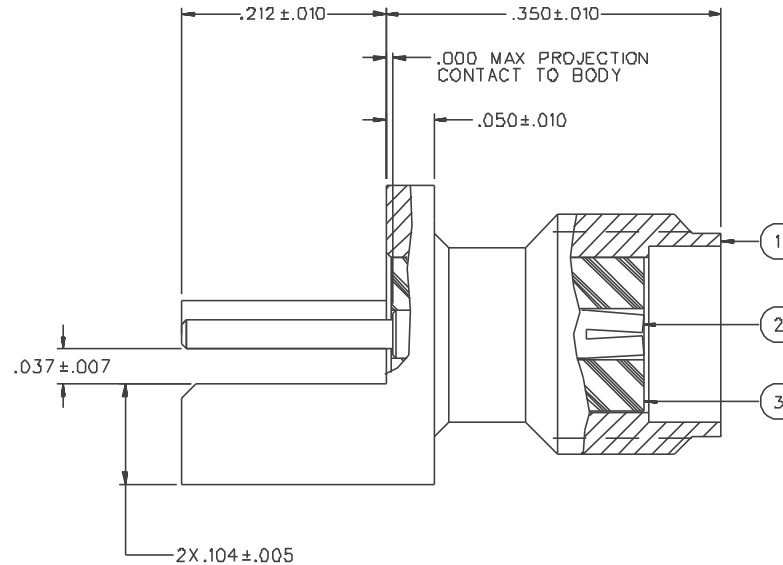
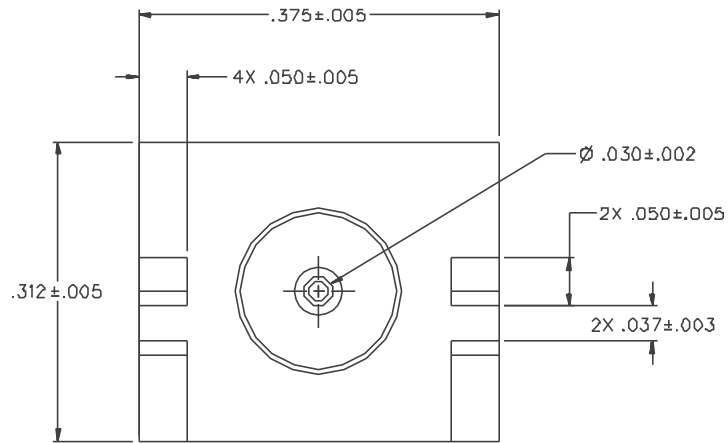

NOTES:

1. SPECIFICATIONS:

IMPEDANCE: 50 OHMS  
 FREQUENCY RANGE: 0-18 GHz  
 VSWR: NOT APPLICABLE  
 WORKING VOLTAGE: 335 VRMS MAX AT SEA LEVEL  
 DIELECTRIC WITHSTANDING VOLTAGE: 1000 VRMS MIN AT SEA LEVEL  
 INSULATION RESISTANCE: 5000 MEGOHM MIN  
 CONTACT RESISTANCE:  
 CENTER CONTACT - INITIAL 3.0 MILLIOHM MAX, AFTER ENVIRONMENTAL 4.0 MILLIOHM MAX  
 OUTER CONDUCTOR - INITIAL 2.0 MILLIOHM MAX AFTER ENVIRONMENTAL NOT APPLICABLE  
 BRAID TO BODY - NOT APPLICABLE  
 CORONA LEVEL: 250 VOLTS MIN AT 70,000 FEET  
 INSERTION LOSS: NOT APPLICABLE  
 RF LEAKAGE: NOT APPLICABLE  
 RF HIGH POTENTIAL WITHSTANDING VOLTAGE: 670 VRMS MIN AT 4 AND 7MHZ

MECHANICAL:

ENGAGE/DISENGAGE TORQUE: 2 INCH-POUNDS MAX  
 MATING TORQUE: 7-10 INCH POUNDS  
 COUPLING PROOF TORQUE: NOT APPLICABLE  
 COUPLING NUT RETENTION: NOT APPLICABLE  
 CONTACT RETENTION: 6 LBS MIN AXIAL FORCE  
 4 IN-OZ MIN RADIAL TORQUE  
 CABLE ACCEPTABILITY: NOT APPLICABLE  
 CABLE HEX CRIMP SIZE: NOT APPLICABLE  
 CABLE RETENTION: NOT APPLICABLE  
 DURABILITY: 500 CYCLES MIN

ENVIRONMENTAL:

(MEETS OR EXCEEDS THE APPLICABLE PARAGRAPH OF MIL-PRF-39012)  
 THERMAL SHOCK: MIL-STD-202, METHOD 107, CONDITION B  
 OPERATING TEMPERATURE: -65 DEG C TO 165 DEG C  
 CORROSION: MIL-STD-202, METHOD 101, CONDITION B  
 SHOCK: MIL-STD-202, METHOD 213, CONDITION I  
 VIBRATION: MIL-STD-202, METHOD 204, CONDITION D  
 MOISTURE RESISTANCE: MIL-STD-202, METHOD 106

DRAWING NO.			
C - 142-0701-881/890			
0 REVISIONS			
ENGINEERING RELEASE			
1	10-27-93	R H P	11-4-93 ECO 42131
ADDED: P/N 142-0701-886 CHANGED: .037±.007 WAS .037±.006, 4X .050±.005 WAS 4X .040±.005, 2X .050±.005 WAS 2X .040±.005, .050±.010 WAS .040±.010			
2	5-10-94	R H P	5-19-94 ECN 42293
ADDED: .000 MAX PROJECTION, CUT AWAY FLANGE DETAIL			
3	10-25-96	R H P	ECN 44265
VERSION UPDATE			
4	3-9-99	R H P	ECN 46208
VERSION UPDATE			
* REVISION NUMBER FOLLOWED BY AN ALPHA * * CHARACTER INDICATES DRAWING CLASS * * ACTION OR PART NUMBER ADDITION ONLY *			
4a	8-13-01	R H P	ECN 47960

CUSTOMER DRAWING

THIS DRAWING TO BE INTERPRETED PER ANSII Y14.5M - 1982

"μSTATION"

COMPANY CONFIDENTIAL

TOLERANCE UNLESS OTHERWISE SPECIFIED	DRAWN BY RJB	DATE 10-11-93	 299 Johnson Ave. P.O. Box 1732 Waseca, MN 56093-0832	
DECIMALS .XX	CHECKED BY RJB	DATE 10-29-93	TITLE JACK ASSEMBLY END LAUNCH SMA	
NATL	APPROVED BY	DATE	CODE NO.	DRAWING NO.
FINISH	RELEASE DATE	11-4-93	C - 142-0701-881/890	
			SCALE 10:1	U/M INCH SHEET 2 OF 2