

DASH NO.	M CODE	MADE FROM
----------	--------	-----------

# GSD

2065-28-9

REVISIONS	
ISSUE	CHANGES
0	ER 39338 JPK 09/29/05
1	CN 39438 C JPK 04/13/06
2	CN 39449 C JPK 05/03/06

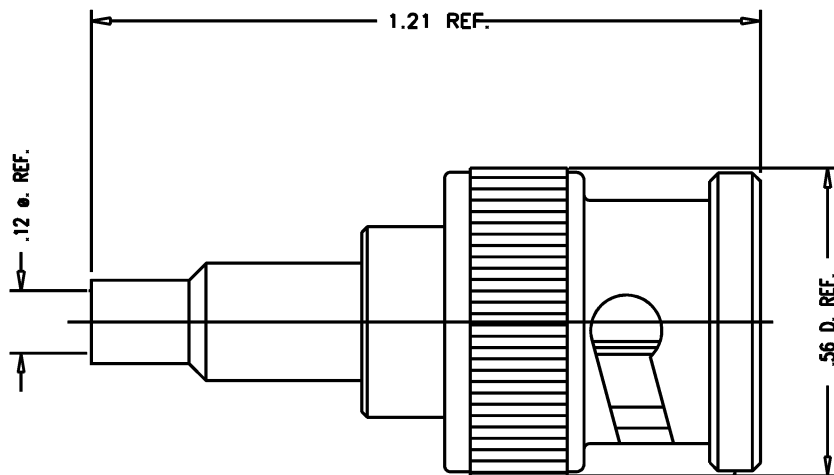

STAMP: KINGS 2065-28-9  
YR WK (DATE CODE)

**NOTES:**

- FOR USE WITH RG-179, 187/U AND BELDEN 9221 & 1790T CABLES.
- FOR CABLING INSTRUCTIONS SEE 3-661-1.
- FOR CRIMPING USE DIE KTH-2258.
- INTERFACE PER KINGS ES-17, FIG 2..
- MATERIALS:
  - INSULATOR-TEFLON, ASTM-D-4894
  - GASKET-SILICONE RUBBER, A-A-59588
  - SPRING WASHER } BER. COP., ASTM-B-196
  - OUTER CONTACT }
  - K-GRIP SLEEVE-COMMERCIAL BRONZE, ASTM-B-135
  - ALL OTHER METAL PARTS-BRASS, ASTM-B16
- FINISHES:
  - CENTER CONTACTS-GOLD PLATE PER ASTM-B488
  - SPRING WASHER-SILVER PLATE PER ASTM-B700
  - ALL OTHER METAL PARTS-KINGS TARNISH RESISTANT NICKEL FINISH (TR-5)
- ELECTRICAL CHARACTERISTICS:
  - NOMINAL IMPEDANCE: 75 OHMS
  - VOLTAGE RATING: 500 VRMS
  - FREQUENCY RANGE: DC TO 3 GHz

2065-28-9SD

SCALE 4:1

APPROX SURFACE AREA

USED ON

REF: EOR 686

PLUG, 75 BNC

DRAWN JLA DATE 07/27/05

DESIGN JLA DATE 07/27/05

APPR. DATE

**KINGS**  
ELECTRONICS CO., INC.  
ROCK HILL, SOUTH CAROLINA 29730

2065-28-9

# GSD