

SUB-ASSEMBLY SHOWN AS SHIPPED

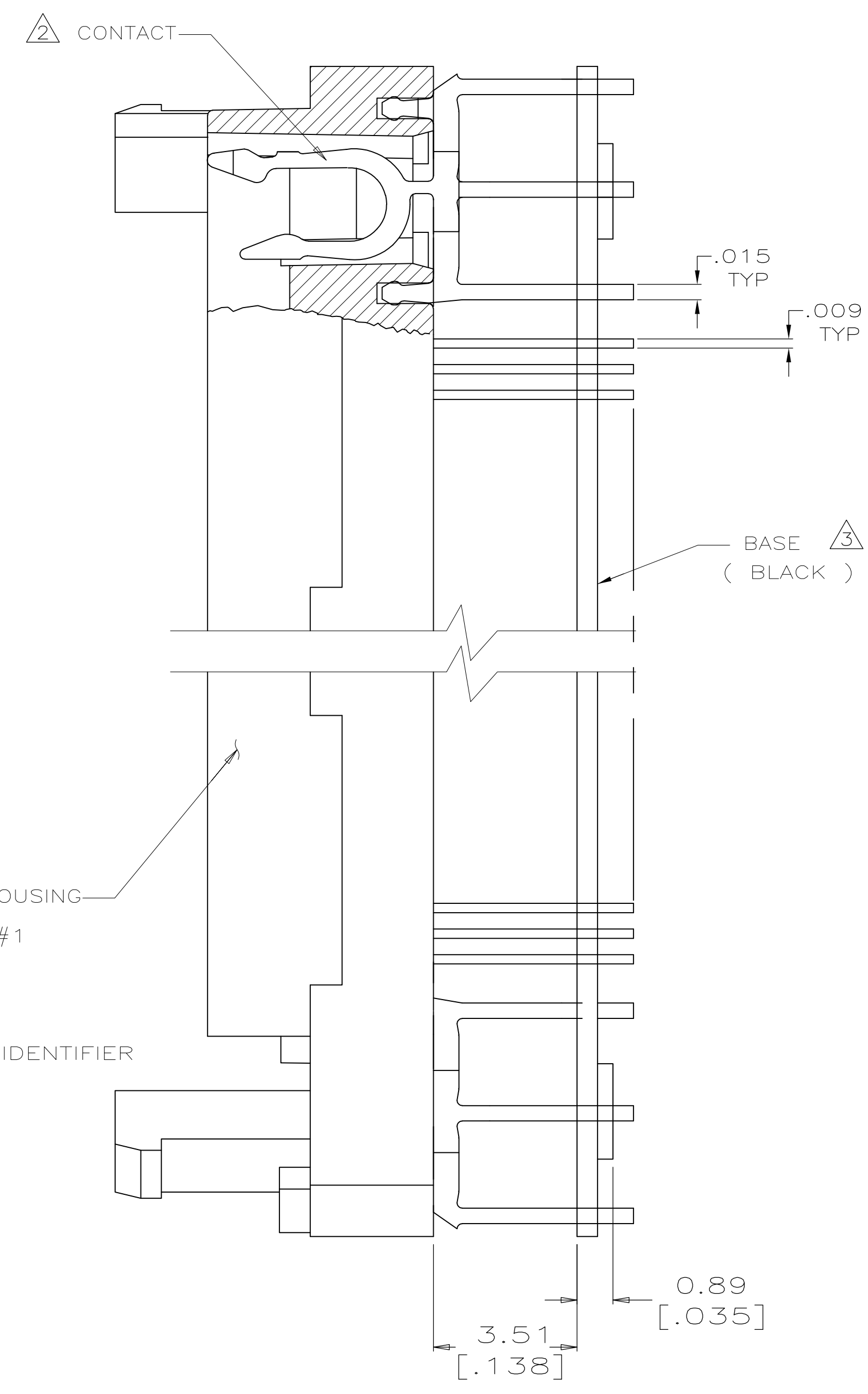

SUB-ASSEMBLY SHOWN IN FINAL POSITION

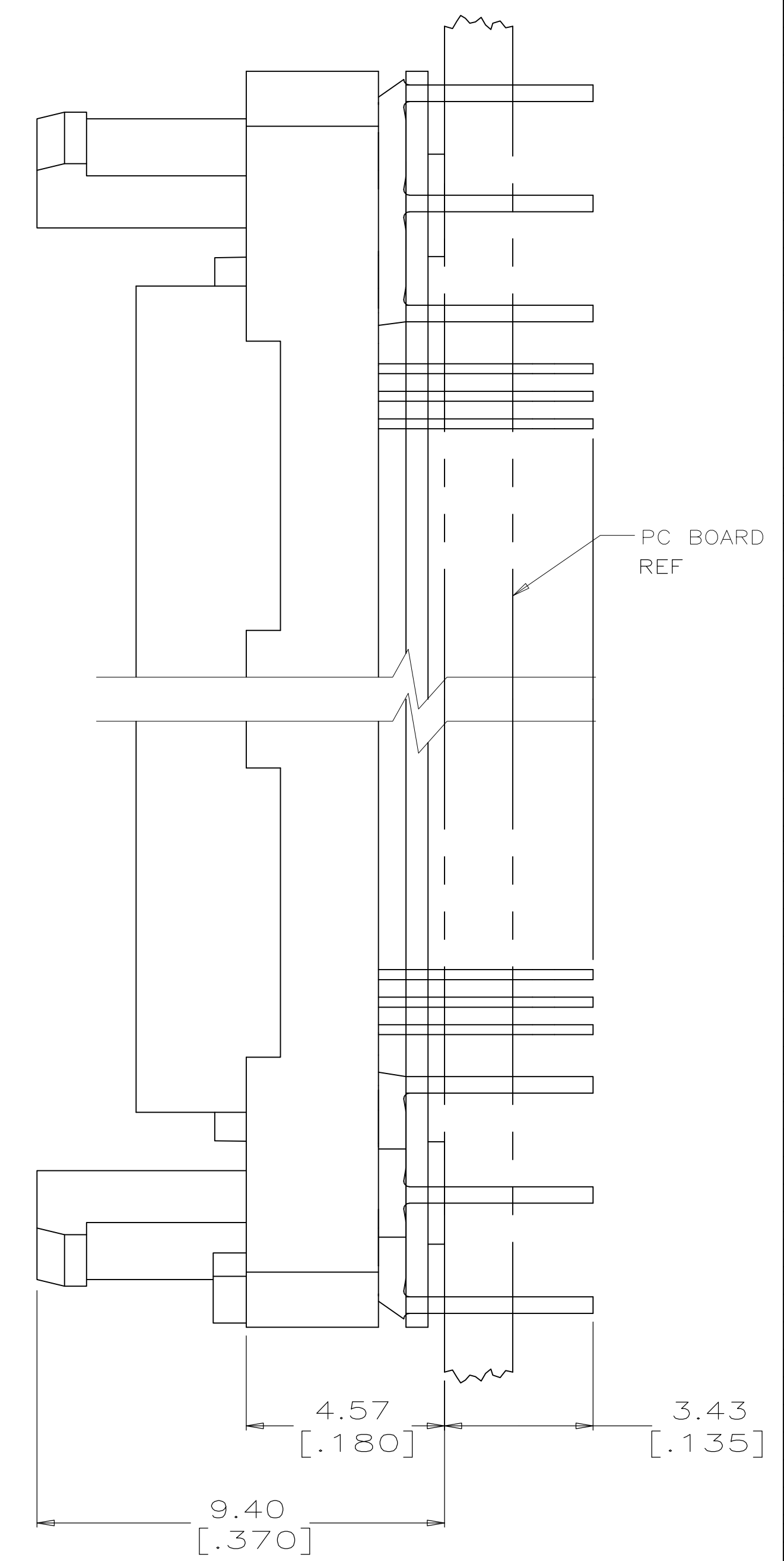

- 1 HOUSING MATERIAL SHALL BE LIQUID CRYSTAL POLYMER. (BLACK)
- 2 CONTACT MATERIAL SHALL BE PHOS. BRONZE. PLATING SHALL BE .000200 [0.00508] MIN. TIN/LEAD OVER .000050 [0.00127] MIN. NICKEL ALL OVER.
- 3 BASE MATERIAL SHALL BE LIQUID CRYSTAL POLYMER. (BLACK)
- 4 CONTACT MATERIAL SHALL BE PHOS. BRONZE. PLATING SHALL BE .000200 [0.00508] MIN. TIN (LEAD FREE) OVER .000050 [0.00127] MIN. NICKEL ALL OVER.

822115-4	4	6.43 [.253]	25.35 [.998]	38.20 [1.504]	2-822114-4	160
822115-3	4	7.73 [.304]	22.76 [.896]	38.20 [1.504]	2-822114-3	144
822115-4	2	6.43 [.253]	25.35 [.998]	38.20 [1.504]	822114-4	160
822115-3	2	7.73 [.304]	22.76 [.896]	38.20 [1.504]	822114-3	144
MATING COVER PART NO.	FINISH	C	B	A	PART NO.	POSN.

THIS DRAWING IS A CONTROLLED DOCUMENT.

DWN	C.WHITT	8-8-91
CHK	R.MILLER	8-8-91
APP'D	G.HOWEL	8-15-91

TE Connectivity

MICRO-PITCH SOCKET, METRIC HOUSING SUB-ASSEMBLY FOR 28mm SQUARE, .65 PITCH PQFP

SIZE: A1 DAGE CODE: C DRAWING NO: 00779 PART NO: 822114

SCALE: 10:1 SHEET: 1 OF 2 REV: E1

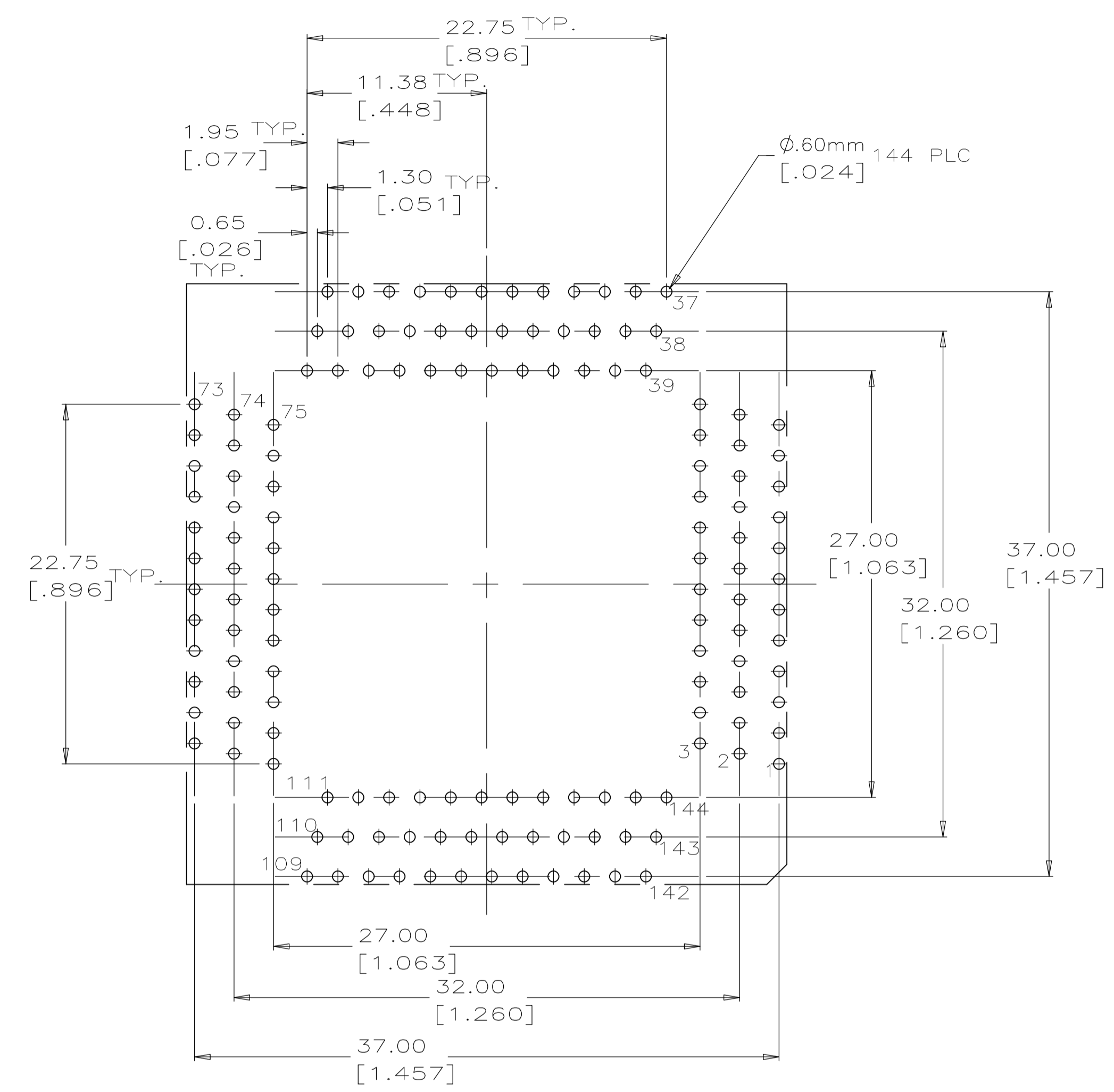

RECOMMENDED P.C. BOARD HOLE PATTERN
SOCKET SIDE
144 POSN.

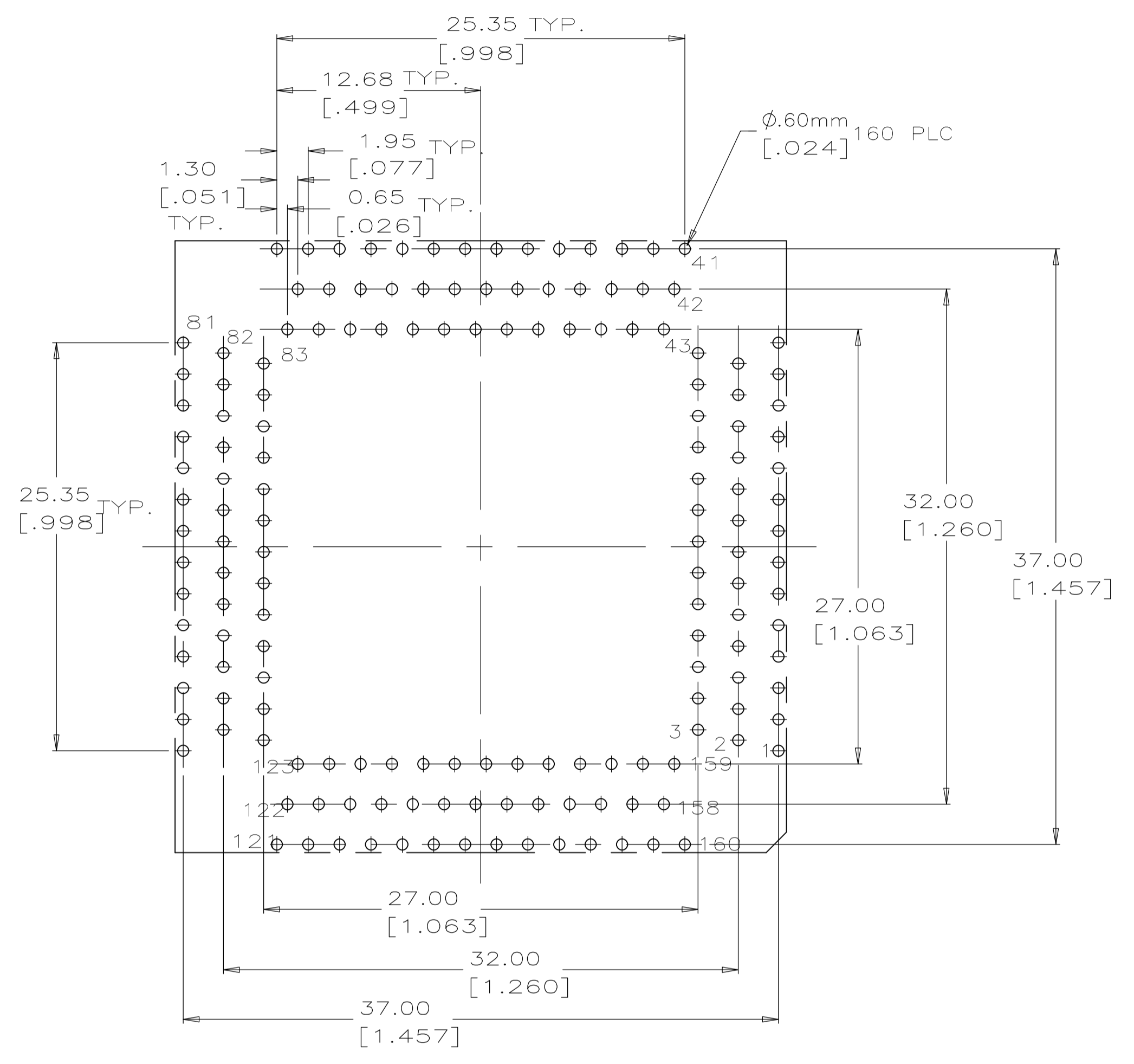

RECOMMENDED P.C. BOARD HOLE PATTERN
SOCKET SIDE
160 POSN.

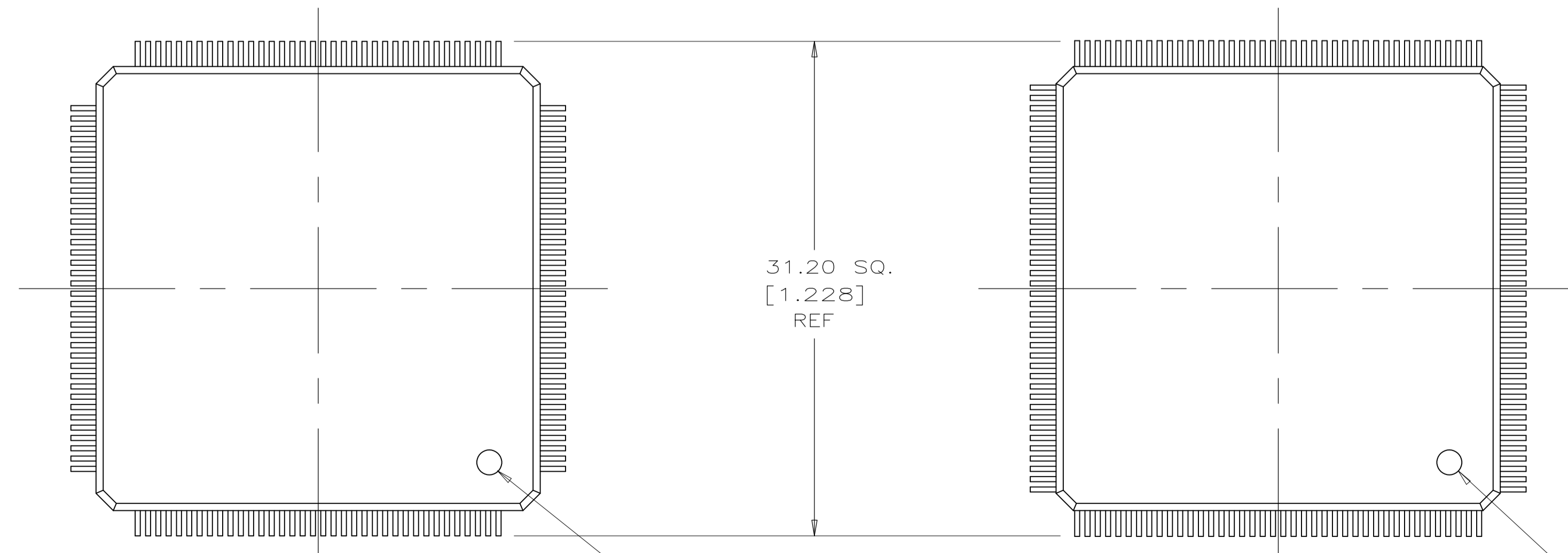

144 POSITION

160 POSITION

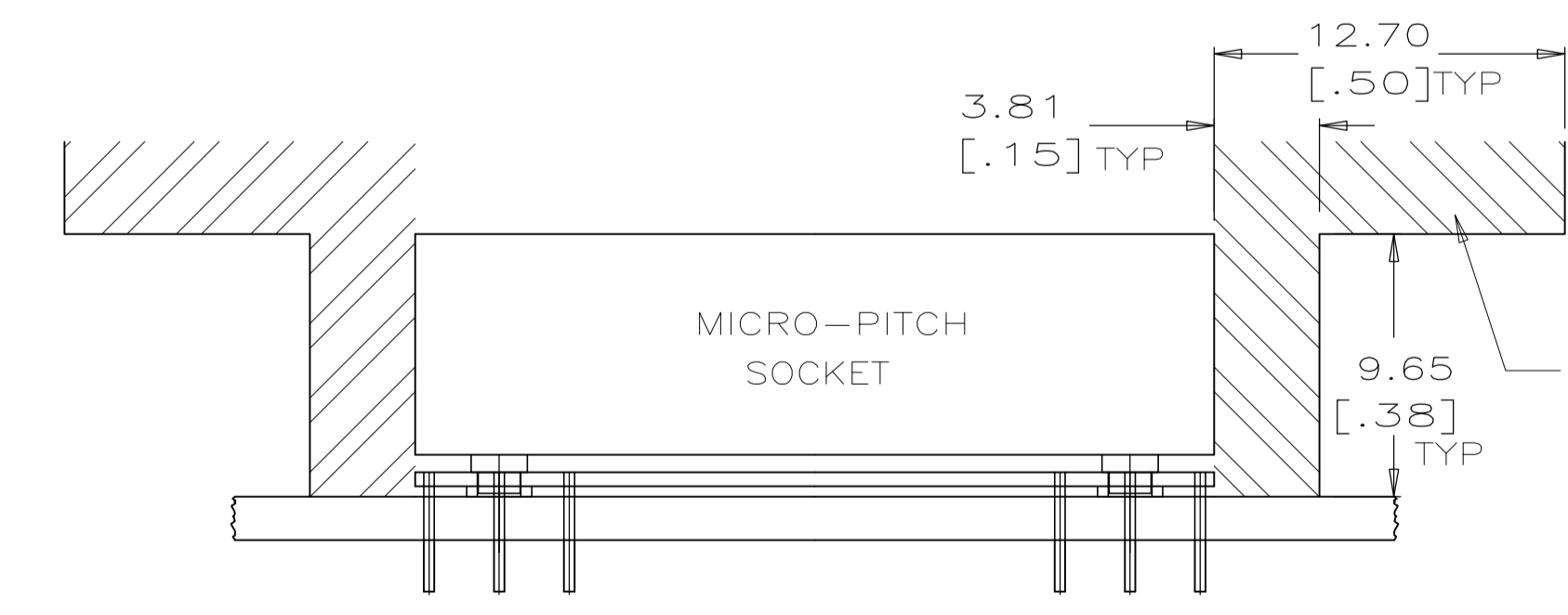

THIS AREA TO BE FREE OF COMPONENTS FOR ACCESS OF THE MICRO-PITCH HAND TOOL. MINIMUM OF TWO OPPOSITE SIDES.

THIS DRAWING IS A CONTROLLED DOCUMENT.		DWN	C. WHITT	8-9-91
DIMENSIONS: INCHES		CHK	R. MILLER	8-9-91
TOLERANCES UNLESS OTHERWISE SPECIFIED:		APVD	G. HOWEL	8-15-91
0 PLC	± -	NAME	MICRO-PITCH SOCKET, METRIC HOUSING SUB-ASSEMBLY FOR 28mm SQUARE, .65 PITCH PQFP	
1 PLC	± -	PRODUCT SPEC	-	
2 PLC	± -	APPLICATION SPEC	-	
3 PLC	± .1mm [.004]	SIZE	A1	00779
4 PLC	± -	SCALE	10:1	822114
ANGLES	± -	WEIGHT	-	
MATERIAL	-	FINISH	-	
CUSTOMER DRAWING		SCALE	10:1	SHEET 2 OF 2
		REV	E1	