

Intelligent +3.0V to +5.5V RS-232 Transceivers

FEATURES

- Meets true EIA/TIA-232-F Standards from a +3.0V to +5.5V power supply
- Interoperable with EIA/TIA-232 and adheres to EIA/TIA-562 down to a +2.7V power source
- AUTO ON-LINE® circuitry automatically wakes up from a 1µA shutdown
- Minimum 250Kbps data rate under load (EB)
- 1 Mbps data rate for high speed RS-232 (EU)
- Regulated Charge Pump Yields Stable RS-232 Outputs Regardless of V_{CC} Variations
- ESD Specifications:
 - ±15KV Human Body Model
 - ±15KV IEC1000-4-2 Air Discharge
 - ±8KV IEC1000-4-2 Contact Discharge

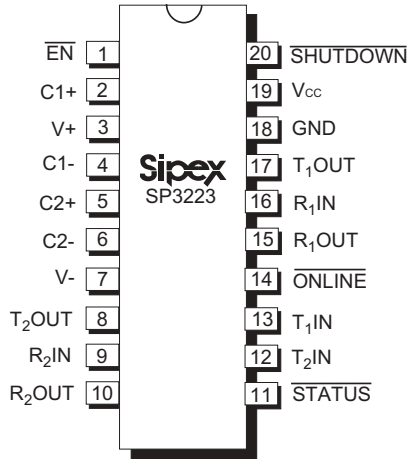

Now Available in Lead Free Packaging

DESCRIPTION

The **SP3223** products are RS-232 transceiver solutions intended for portable applications such as notebook and hand held computers. The **SP3223** use an internal high-efficiency, charge-pump power supply that requires only 0.1µF capacitors in 3.3V operation. This charge pump and **Sipex's** driver architecture allow the **SP3223** series to deliver compliant RS-232 performance from a single power supply ranging from +3.3V to +5.0V. The **SP3223** is a 2-driver/2-receiver device ideal for laptop/notebook computer and PDA applications.

The AUTO ON-LINE® feature allows the device to automatically "wake-up" during a shutdown state when an RS-232 cable is connected and a connected peripheral is turned on. Otherwise, the device automatically shuts itself down drawing less than 1µA.

SELECTION TABLE

Device	Power Supplies	RS-232 Drivers	RS-232 Receivers	External Components	AUTO ON-LINE® Circuitry	TTL 3-State	# of Pins	Gauranteed Data Rate	ESD Rating
SP3223	+3.0V to +5.5V	2	2	4 capacitors	YES	YES	20	120	2kV
SP3223E	+3.0V to +5.5V	2	2	4 capacitors	YES	YES	20	120	15kV
SP3223B	+3.0V to +5.5V	2	2	4 capacitors	YES	YES	20	250	2kV
SP3223EB	+3.0V to +5.5V	2	2	4 capacitors	YES	YES	20	250	15kV
SP3223U	+3.0V to +5.5V	2	2	4 capacitors	YES	YES	20	1000	2kV
SP3223EU	+3.0V to +5.5V	2	2	4 capacitors	YES	YES	20	1000	15kV

Applicable U.S. Patents - 5,306,954; and other patents pending.

ABSOLUTE MAXIMUM RATINGS

These are stress ratings only and functional operation of the device at these ratings or any other above those indicated in the operation sections of the specifications below is not implied. Exposure to absolute maximum rating conditions for extended periods of time may affect reliability and cause permanent damage to the device.

V _{CC}	-0.3V to +6.0V
V+ (NOTE 1).....	-0.3V to +7.0V
V- (NOTE 1).....	+0.3V to -7.0V
V+ + V- (NOTE 1).....	+13V
I _{CC} (DC V _{CC} or GND current).....	±100mA

Input Voltages

TxIN, ONLINE, SHUTDOWN, EN (SP3223).....	-0.3V to +6.0V
RxIN.....	±15V

Output Voltages

TxOUT.....	±13.2V
RxOUT, STATUS.....	-0.3V to (V _{CC} + 0.3V)

Short-Circuit Duration

TxOUT.....	Continuous
Storage Temperature.....	-65°C to +150°C

Power Dissipation per package

20-pin SSOP (derate 9.25mW/°C above +70°C)...	750mW
20-pin TSSOP (derate 11.1mW/°C above +70°C)...	900mW

NOTE 1: V+ and V- can have maximum magnitudes of 7V, but their absolute difference cannot exceed 13V.

ELECTRICAL CHARACTERISTICS

Unless otherwise noted, the following specifications apply for V_{CC} = +3.0V to +5.5V with T_{AMB} = T_{MIN} to T_{MAX}. Typical values apply at V_{CC} = +3.3V or +5.0V and T_{AMB} = 25°C (Note 2).

PARAMETER	MIN.	TYP.	MAX.	UNITS	CONDITIONS
DC CHARACTERISTICS					
Supply Current, AUTO ON-LINE®		1.0	10	μA	All RxIN open, $\overline{\text{ONLINE}} = \text{GND}$, $\overline{\text{SHUTDOWN}} = V_{CC}$, TxIN=V _{CC} or GND, V _{CC} = +3.3V, T _{AMB} = +25° C
Supply Current, Shutdown		1.0	10	μA	$\overline{\text{SHUTDOWN}} = \text{GND}$, TxIN=V _{CC} or GND, V _{CC} = +3.3V, T _{AMB} = +25° C
Supply Current, AUTO ON-LINE® Disabled		0.3	1.0	mA	$\overline{\text{ONLINE}} = \overline{\text{SHUTDOWN}} = V_{CC}$, no load, V _{CC} = +3.3V, T _{AMB} = +25° C
LOGIC INPUTS AND RECEIVER OUTPUTS					
Input Logic Threshold LOW HIGH	GND 2.0		0.8 V _{CC}	V	V _{CC} = +3.3V or +5.0V; TxIN, EN (SP3223), $\overline{\text{ONLINE}}$, $\overline{\text{SHUTDOWN}}$
Input Leakage Current		±0.01	±1.0	μA	TxIN, EN, $\overline{\text{ONLINE}}$, $\overline{\text{SHUTDOWN}}$, T _{AMB} = +25° C, V _{IN} = 0V to V _{CC}
Output Leakage Current		±0.05	±10	μA	Receivers disabled, V _{OUT} = 0V to V _{CC}
Output Voltage LOW			0.4	V	I _{OUT} = 1.6mA
Output Voltage HIGH	V _{CC} - 0.6	V _{CC} - 0.1		V	I _{OUT} = -1.0mA

NOTE 2: C1 - C4 0.1μF, tested at 3.3V ±10%.

C1 = 0.047μF, C2-C4 = 0.33μF, tested at 5V±10%.

ELECTRICAL CHARACTERISTICS

Unless otherwise noted, the following specifications apply for $V_{CC} = +3.0V$ to $+5.5V$ with $T_{AMB} = T_{MIN}$ to T_{MAX} . Typical values apply at $V_{CC} = +3.3V$ or $+5.0V$ and $T_{AMB} = 25^{\circ}C$ (Note 2).

PARAMETER	MIN.	TYP.	MAX.	UNITS	CONDITIONS
DRIVER OUTPUTS					
Output Voltage Swing	±5.0	±5.4		V	All driver outputs loaded with 3KΩ to GND, $T_{AMB} = +25^{\circ}C$
Output Resistance	300			Ω	$V_{CC} = V+ = V- = 0V$, $V_{OUT} = \pm 2V$
Output Short-Circuit Current		±35 ±70	±60 ±100	mA	$V_{OUT} = 0V$ $V_{OUT} = \pm 15V$
Output Leakage Current			±25	μA	$V_{CC} = 0V$ or $3.0V$ to $5.5V$, $V_{OUT} = \pm 12V$, Drivers disabled
RECEIVER INPUTS					
Input Voltage Range	-15		15	V	
Input Threshold LOW	0.6	1.2		V	$V_{CC} = 3.3V$
Input Threshold LOW	0.8	1.5		V	$V_{CC} = 5.0V$
Input Threshold HIGH		1.5	2.4	V	$V_{CC} = 3.3V$
Input Threshold HIGH		1.8	2.4	V	$V_{CC} = 5.0V$
Input Hysteresis		0.3		V	
Input Resistance	3	5	7	kΩ	
AUTO ON-LINE® CIRCUITRY CHARACTERISTICS (ONLINE = GND, SHUTDOWN = V_{CC})					
STATUS Output Voltage LOW			0.4	V	$I_{OUT} = 1.6mA$
STATUS Output Voltage HIGH	$V_{CC} - 0.6$			V	$I_{OUT} = -1.0mA$
Receiver Threshold to Drivers Enabled (t_{ONLINE})		200		μS	Figure 14
Receiver Positive or Negative Threshold to STATUS HIGH (t_{STSH})		0.5		μS	Figure 14
Receiver Positive or Negative Threshold to STATUS LOW (t_{STSL})		20		μS	Figure 14

NOTE 2: C1 - C4 0.1μF, tested at 3.3V ±10%.
C1 = 0.047μF, C2-C4 = 0.33μF, tested at 5V±10%.

TIMING CHARACTERISTICS

Unless otherwise noted, the following specifications apply for $V_{CC} = +3.0V$ to $+5.5V$ with $T_{AMB} = T_{MIN}$ to T_{MAX} . Typical values apply at $V_{CC} = +3.3V$ or $+5.0V$ and $T_{AMB} = 25^{\circ}C$.

PARAMETER	MIN.	TYP.	MAX.	UNITS	CONDITIONS
Maximum Data Rate					
SP3223E	120	235		kbps	$R_L = 3K\Omega$, $C_L = 1000pF$, one driver active
SP3223EB	250				
SP3223EH	460				
SP3223EU	1000				$R_L = 3K\Omega$, $C_L = 250pF$, one driver active
Receiver Propagation Delay					
t_{PHL}		0.15		μs	Receiver input to Receiver output, $C_L = 150pF$
t_{PLH}					
Receiver Output Enable Time		200		ns	Normal operation
Receiver Output Disable Time		200		ns	Normal operation
Driver Skew					
E,EB		100	500	ns	$ t_{PHL} - t_{PLH} $, $T_{AMB} = 25^{\circ}C$
EH, EU		50	100		
Receiver Skew		200	1000	ns	$ t_{PHL} - t_{PLH} $
Transition-Region Slew Rate					
E,EB			30	V/ μs	$V_{CC} = 3.3V$, $R_L = 3K\Omega$, $T_{AMB} = 25^{\circ}C$, measurements taken from $-3.0V$ to $+3.0V$ or $+3.0V$ to $-3.0V$
EH		60			
EU		90			

TYPICAL OPERATING CIRCUIT

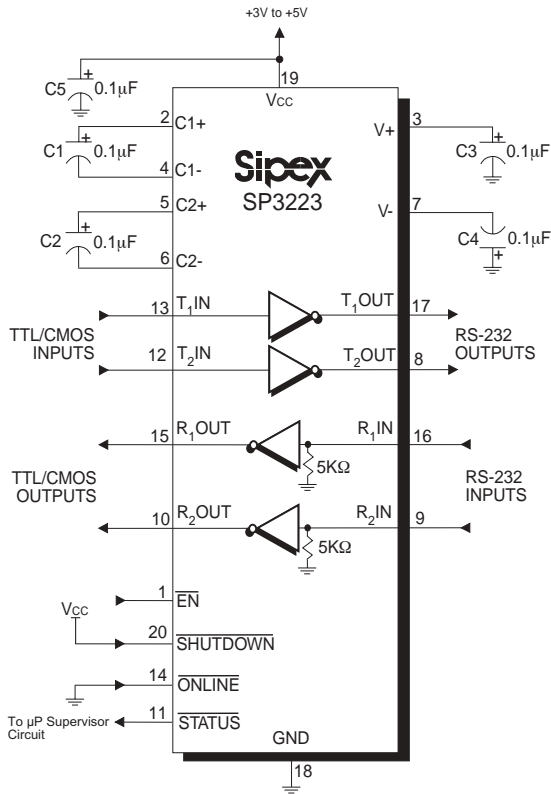

Figure 4. SP3223 Typical Operating Circuit

TYPICAL PERFORMANCE CHARACTERISTICS

Unless otherwise noted, the following performance characteristics apply for $V_{CC} = +3.3V$, 250Kbps data rate, all drivers loaded with $3k\Omega$, $0.1\mu F$ charge pump capacitors, and $T_{AMB} = +25^{\circ}C$.

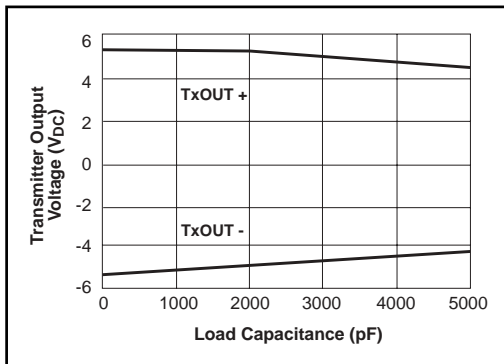

Figure 1. Transmitter Output Voltage VS. Load Capacitance for the SP3223EB

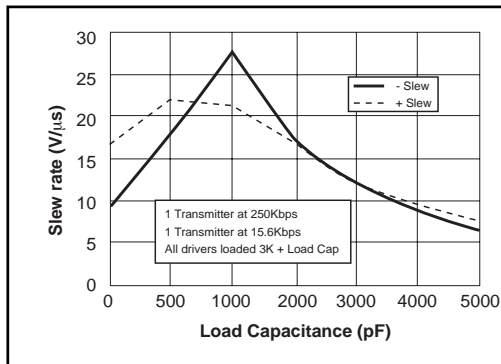

Figure 2. Slew Rate VS. Load Capacitance for the SP3223EB

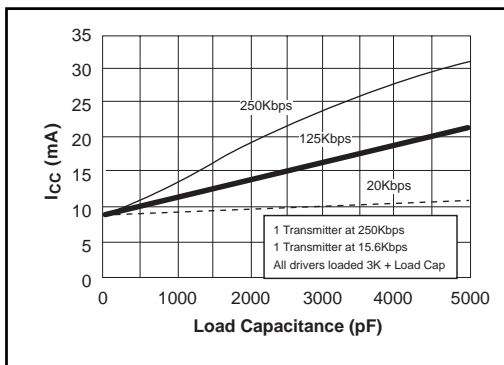

Figure 3. Supply Current VS. Load Capacitance when Transmitting Data for the SP3223EB

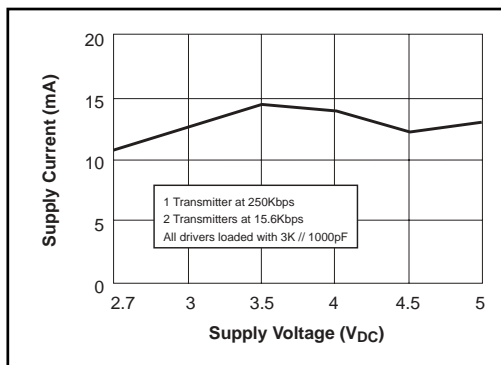

Figure 4. Supply Current VS. Supply Voltage for the SP3243EB

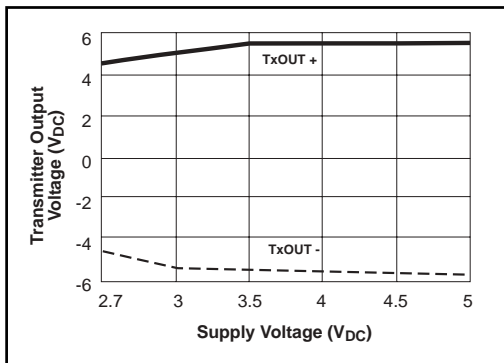

Figure 5. Transmitter Output Voltage VS. Supply Voltage for the SP3243EB

TYPICAL PERFORMANCE CHARACTERISTICS

Unless otherwise noted, the following performance characteristics apply for $V_{CC} = +3.3V$, 1000Kbps data rate, all drivers loaded with $3k\Omega$, $0.1\mu F$ charge pump capacitors, and $T_{AMB} = +25^{\circ}C$.

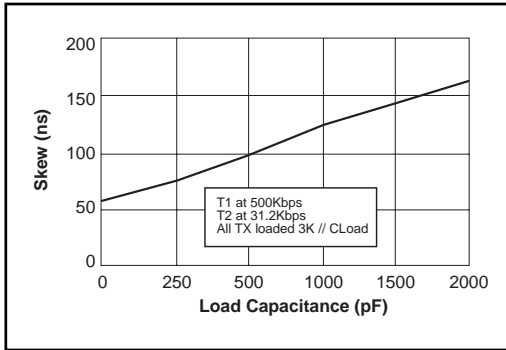

Figure 6. Transmitter Skew VS. Load Capacitance for the 3223EU

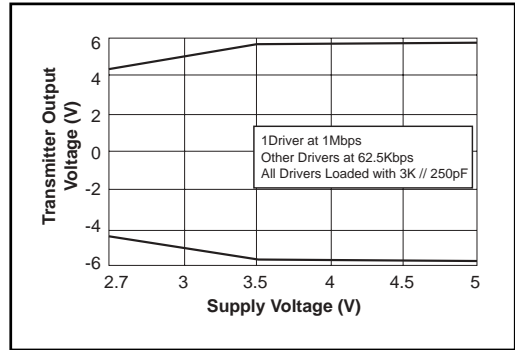

Figure 7 Transmitter Output Voltage VS. Supply Voltage for the SP3223EU

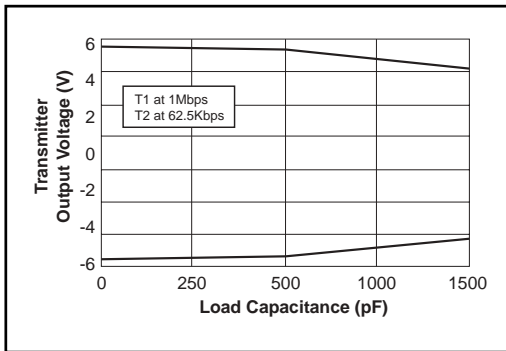

Figure 8. Transmitter Output Voltage VS. Load Capacitance for the SP3223EU

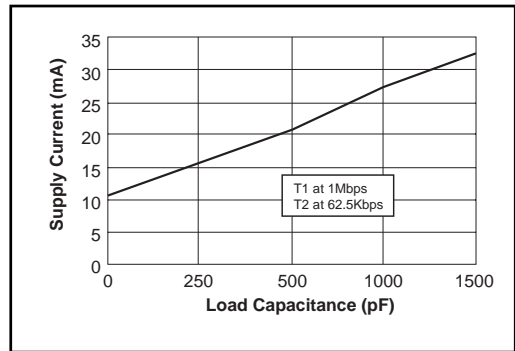

Figure 9. Supply Current VS. Load Capacitance for the SP3223EU

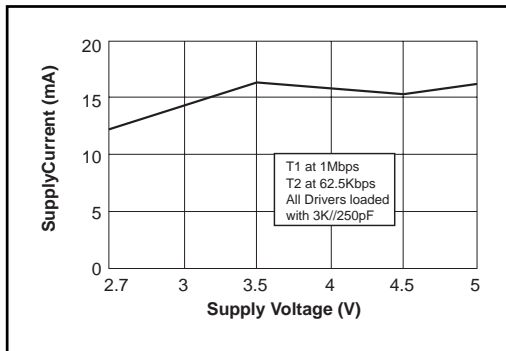

Figure 10. Supply Current VS. Supply Voltage for the SP3223EU

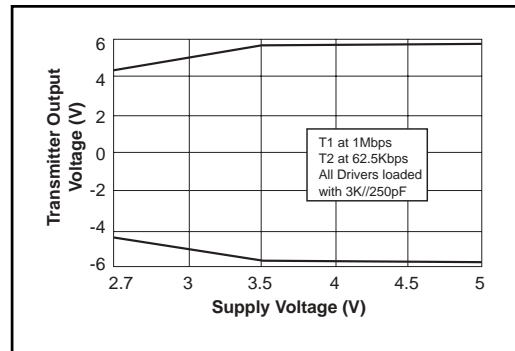

Figure 11. Transmitter Output Voltage VS. Supply Voltage for the SP3223EU

NAME	FUNCTION	PIN #
$\overline{\text{EN}}$	Receiver Enable. Apply logic LOW for normal operation. Apply logic HIGH to disable the receiver outputs (high-Z state).	1
C1+	Positive terminal of the voltage doubler charge-pump capacitor.	2
V+	Regulated +5.5V output generated by the charge pump.	3
C1-	Negative terminal of the voltage doubler charge-pump capacitor.	4
C2+	Positive terminal of the inverting charge-pump capacitor.	5
C2-	Negative terminal of the inverting charge-pump capacitor.	6
V-	Regulated -5.5V output generated by the charge pump.	7
T ₂ OUT	RS-232 driver output.	8
R ₂ IN	RS-232 receiver input.	9
R ₂ OUT	TTL/CMOS receiver output.	10
$\overline{\text{STATUS}}$	TTL/CMOS Output indicating online and shutdown status.	11
T ₂ IN	TTL/CMOS driver input.	12
T ₁ IN	TTL/CMOS driver input.	13
$\overline{\text{ONLINE}}$	Apply logic HIGH to override <i>AUTO ON-LINE</i> [®] circuitry keeping drivers active (SHUTDOWN must also be logic HIGH, refer to Table 2).	14
R ₁ OUT	TTL/CMOS receiver output.	15
R ₁ IN	RS-232 receiver input.	16
T ₁ OUT	RS-232 driver output.	17
GND	Ground.	18
V _{CC}	+3.0V to +5.5V supply voltage.	19
$\overline{\text{SHUTDOWN}}$	Apply logic LOW to shut down drivers and charge pump. This overrides all <i>AUTO ON-LINE</i> [®] circuitry and <i>ONLINE</i> (refer to Table 2).	20

DESCRIPTION

The **SP3223** is a 2-driver/2-receiver device ideal for portable or handheld applications. The **SP3223** transceivers meet the EIA/TIA-232 and ITU-T V.28/V.24 communication protocols and can be implemented in battery-powered, portable, or handheld applications such as notebook or handheld computers. The **SP3223** devices feature **Sipex's** proprietary and patented (U.S.-- 5,306,954) on-board charge pump circuitry that generates $\pm 5.5V$ RS-232 voltage levels from a single $+3.0V$ to $+5.5V$ power supply. The **SP3223** devices operate at this typical data rate when fully loaded.

The **SP3223** series is an ideal choice for power sensitive designs. Featuring **AUTO ON-LINE**[®] circuitry, the SP3223 reduces the power supply drain to a $1\mu A$ supply current. In many portable or handheld applications, an RS-232 cable can be disconnected or a connected peripheral can be turned off. Under these conditions, the internal charge pump and the drivers will be shut down.

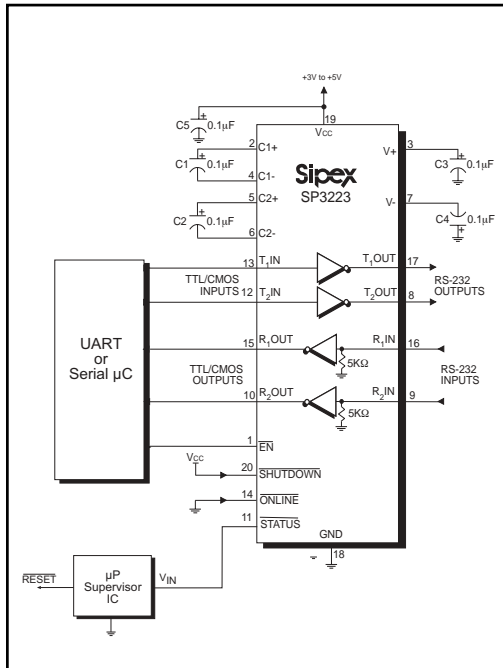

Figure 11. Interface Circuitry Controlled by Microprocessor Supervisory Circuit

Otherwise, the system automatically comes online. This feature allows design engineers to address power saving concerns without major design changes.

THEORY OF OPERATION

The **SP3223** series is made up of four basic circuit blocks:

1. Drivers, 2. Receivers, 3. the Sipex proprietary charge pump, and 4. **AUTO ON-LINE**[®] circuitry.

Drivers

The drivers are inverting level transmitters that convert TTL or CMOS logic levels to 5.0V EIA/TIA-232 levels with an inverted sense relative to the input logic levels. Typically, the RS-232 output voltage swing is $\pm 5.4V$ with no load and $\pm 5V$ minimum fully loaded. The driver outputs are protected against infinite short-circuits to ground without degradation in reliability. These drivers comply with the EIA-TIA-232F and all previous RS-232 versions. Unused driver inputs should be connected to GND or V_{CC} .

The drivers can guarantee output data rates fully loaded with $3K\Omega$ in parallel with $1000pF$, (SP3223EU, $C_L = 250pF$) ensuring compatibility with PC-to-PC communication software.

The slew rate of the driver output on the E and EB versions is internally limited to a maximum of $30V/\mu s$ in order to meet the EIA standards (EIA RS-232D 2.1.7, Paragraph 5). The Slew Rate of H and U versions is not limited to enable higher speed data transfers. The transition of the loaded output from HIGH to LOW also meets the monotonicity requirements of the standard.

Figure 12 shows a loopback test circuit used to test the RS-232 Drivers. *Figure 13* shows the test results where one driver was active at 235Kbps and all drivers are loaded with an RS-232 receiver in parallel with a $1000pF$ capacitor. RS-232 data transmission rate of 120Kbps to 1Mbps. provide compatibility with designs in personal computer peripherals and LAN applications.

DEVICE: SP3223			
$\overline{\text{SHUTDOWN}}$	$\overline{\text{EN}}$	$T_x \text{ OUT}$	$R_x \text{ OUT}$
0	0	High Z	Active
0	1	High Z	High Z
1	0	Active	Active
1	1	Active	High Z

Table 2. $\overline{\text{SHUTDOWN}}$ and $\overline{\text{EN}}$ Truth Tables

Note: In $\text{AUTO ON-LINE}^{\text{®}}$ Mode where $\text{ONLINE} = \text{GND}$ and $\overline{\text{SHUTDOWN}} = V_{CC}$ the device will shut down if there is no activity present at the Receiver inputs.

Receivers

The receivers convert $\pm 5.0\text{V}$ EIA/TIA-232 levels to TTL or CMOS logic output levels. Receivers have an inverting output that can be disabled by using the $\overline{\text{EN}}$ pin.

Receivers are active when the $\text{AUTO ON-LINE}^{\text{®}}$ circuitry is enabled or when in shutdown. During the shutdown, the receivers will continue to be active. If there is no activity present at the receivers for a period longer than $100\mu\text{s}$ or when SHUTDOWN is enabled, the device goes into a standby mode where the circuit draws $1\mu\text{A}$. Driving EN to a logic HIGH forces the outputs of the receivers into high-impedance. The truth table logic of the **SP3223** driver and receiver outputs can be found in Table 2.

Since receiver input is usually from a transmission line where long cable lengths and system interference can degrade the signal, the inputs have a typical hysteresis margin of 300mV . This ensures that the receiver is virtually immune to noisy transmission lines. Should an input be left unconnected, an internal $5\text{K}\Omega$ pulldown resistor to ground will commit the output of the receiver to a HIGH state.

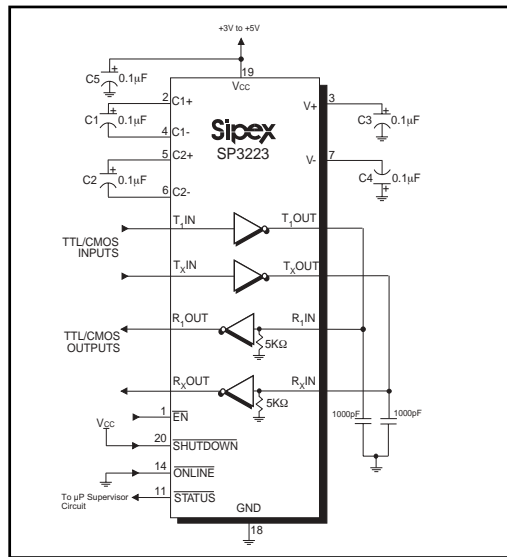

Figure 12. Loopback Test Circuit for RS-232 Driver Data Transmission Rates

Charge Pump

The charge pump is a **SipeX**-patented design (U.S. 5,306,954) and uses a unique approach compared to older less-efficient designs. The charge pump still requires four external capacitors, but uses a four-phase voltage shifting technique to attain symmetrical 5.5V power supplies. The internal power supply

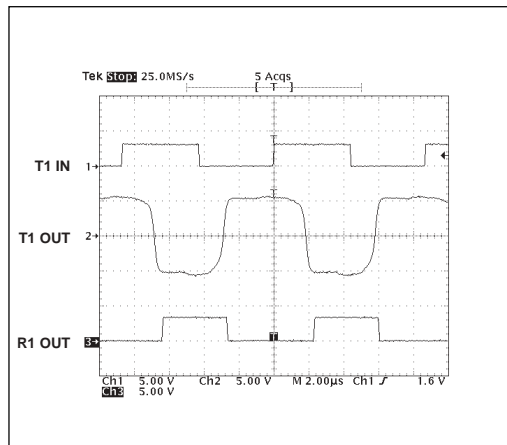

Figure 13. Loopback Test Circuit result at 235Kbps (All Drivers Fully Loaded)

consists of a regulated dual charge pump that provides output voltages 5.5V regardless of the input voltage (V_{CC}) over the +3.0V to +5.5V range. This is important to maintain compliant RS-232 levels regardless of power supply fluctuations.

The charge pump operates in a discontinuous mode using an internal oscillator. If the output voltages are less than a magnitude of 5.5V, the charge pump is enabled. If the output voltages exceed a magnitude of 5.5V, the charge pump is disabled. This oscillator controls the four phases of the voltage shifting. A description of each phase follows.

Phase 1

— V_{SS} charge storage — During this phase of the clock cycle, the positive side of capacitors C_1 and C_2 are initially charged to V_{CC} . C_1^+ is then switched to GND and the charge in C_1^- is transferred to C_2^- . Since C_2^+ is connected to V_{CC} , the voltage potential across capacitor C_2 is now 2 times V_{CC} .

Phase 2

— V_{SS} transfer — Phase two of the clock connects the negative terminal of C_2 to the V_{SS} storage capacitor and the positive terminal of C_2 to GND. This transfers a negative generated voltage to C_3 . This generated voltage is regulated to a minimum voltage of -5.5V. Simultaneous with the transfer of the voltage to C_3 , the positive side of capacitor C_1 is switched to V_{CC} and the negative side is connected to GND.

Phase 3

— V_{DD} charge storage — The third phase of the clock is identical to the first phase — the charge transferred in C_1 produces $-V_{CC}$ in the negative terminal of C_1 , which is applied to the negative side of capacitor C_2 . Since C_2^+ is at V_{CC} , the voltage potential across C_2 is 2 times V_{CC} .

Phase 4

— V_{DD} transfer — The fourth phase of the clock connects the negative terminal of C_2 to GND, and transfers this positive generated voltage across C_2 to C_4 , the V_{DD} storage capacitor. This

voltage is regulated to +5.5V. At this voltage, the internal oscillator is disabled. Simultaneous with the transfer of the voltage to C_4 , the positive side of capacitor C_1 is switched to V_{CC} and the negative side is connected to GND, allowing the charge pump cycle to begin again. The charge pump cycle will continue as long as the operational conditions for the internal oscillator are present.

Since both V^+ and V^- are separately generated from V_{CC} , in a no-load condition V^+ and V^- will be symmetrical. Older charge pump approaches that generate V^- from V^+ will show a decrease in the magnitude of V^- compared to V^+ due to the inherent inefficiencies in the design.

AUTO ON-LINE® Circuitry

The **SP3223** devices have a patent pending **AUTO ON-LINE®** circuitry on board that saves power in applications such as laptop computers, PDA's, and other portable systems.

The **SP3223** devices incorporate an **AUTO ON-LINE®** circuit that automatically enables itself when the external transmitters are enabled and the cable is connected. Conversely, the **AUTO ON-LINE®** circuit also disables most of the internal circuitry when the device is not being used and goes into a standby mode where the device typically draws 1 μ A. This function can also be externally controlled by the **ONLINE** pin. When this pin is tied to a logic LOW, the **AUTO ON-LINE®** function is active. Once active, the device is enabled until there is no activity on the receiver inputs. The receiver input typically sees at least $\pm 3V$, which are generated from the transmitters at the other end of the cable with a $\pm 5V$ minimum. When the external transmitters are disabled or the cable is disconnected, the receiver inputs will be pulled down by their internal 5k Ω resistors to ground. When this occurs over a period of time, the internal transmitters will be disabled and the device goes into a shutdown or standby mode. When **ONLINE** is HIGH, the **AUTO ON-LINE®** mode is disabled.

The **AUTO ON-LINE**[®] circuit has two stages:

- 1) Inactive Detection
- 2) Accumulated Delay

The first stage, shown in *Figure 20*, detects an inactive input. A logic HIGH is asserted on R_{xINACT} if the cable is disconnected or the external transmitters are disabled. Otherwise, R_{xINACT} will be at a logic LOW. This circuit is duplicated for each of the other receivers.

The clock rate for the charge pump typically operates at above 250kHz. The external capacitors can be as low as 0.1 μ F with a 16V breakdown voltage rating.

The second stage of the **AUTO ON-LINE**[®] circuitry, shown in *Figure 21*, processes all the receiver's R_{xINACT} signals with an accumulated delay that disables the device to a 1 μ A supply current.

The \overline{STATUS} pin goes to a logic LOW when the cable is disconnected, the external transmitters are disabled, or the $\overline{SHUTDOWN}$ pin is invoked. The typical accumulated delay is around 20 μ s.

When the **SP3223** drivers or internal charge pump are disabled, the supply current is reduced to 1 μ A. This can commonly occur in handheld

or portable applications where the RS-232 cable is disconnected or the RS-232 drivers of the connected peripheral are turned off.

The **AUTO ON-LINE**[®] mode can be disabled by the $\overline{SHUTDOWN}$ pin. If this pin is a logic LOW, the **AUTO ON-LINE**[®] function will not operate regardless of the logic state of the \overline{ONLINE} pin. *Table 3* summarizes the logic of the **AUTO ON-LINE**[®] operating modes. The truth table logic of the **SP3223** driver and receiver outputs can be found in *Table 2*.

The \overline{STATUS} pin outputs a logic LOW signal if the device is shutdown. This pin goes to a logic HIGH when the external transmitters are enabled and the cable is connected.

When the **SP3223** devices are shut down, the charge pumps are turned off. V+ charge pump output decays to V_{CC} , the V- output decays to GND. The decay time will depend on the size of capacitors used for the charge pump. Once in shutdown, the time required to exit the shut down state and have valid V+ and V- levels is typically 200 μ s.

For easy programming, the \overline{STATUS} can be used to indicate \overline{DTR} or a Ring Indicator signal. Tying \overline{ONLINE} and $\overline{SHUTDOWN}$ together will bypass the **AUTO ON-LINE**[®] circuitry so this connection acts like a shutdown input pin

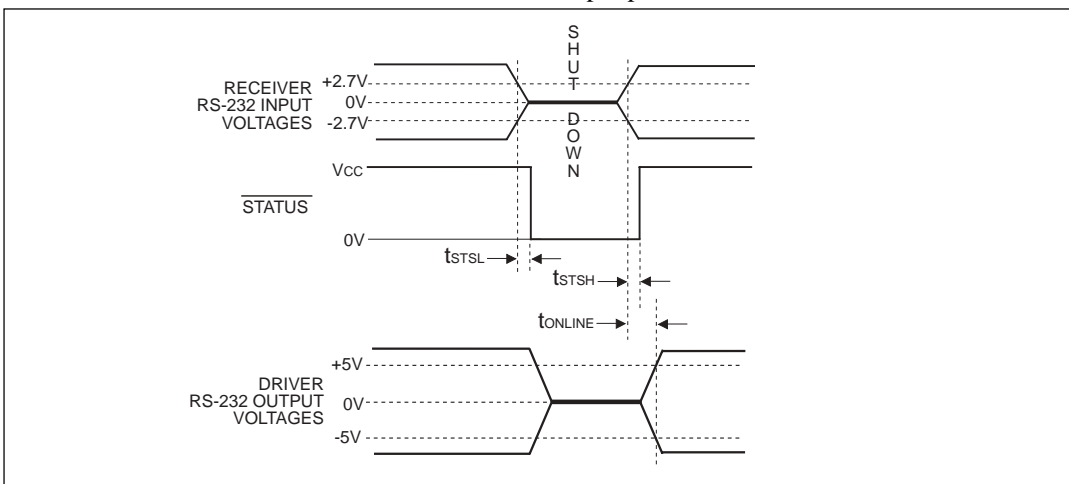

Figure 14. AUTO ON-LINE[®] Timing Waveforms

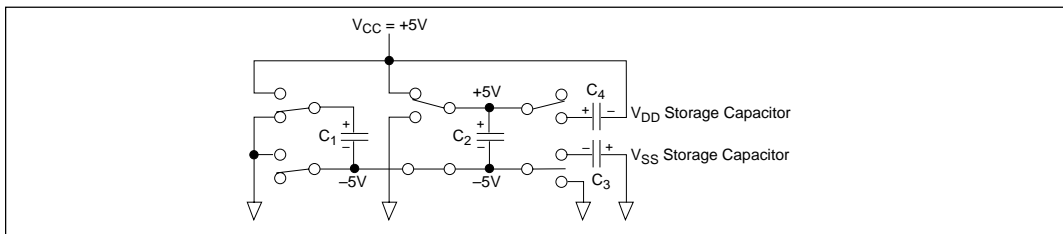

Figure 15. Charge Pump — Phase 1

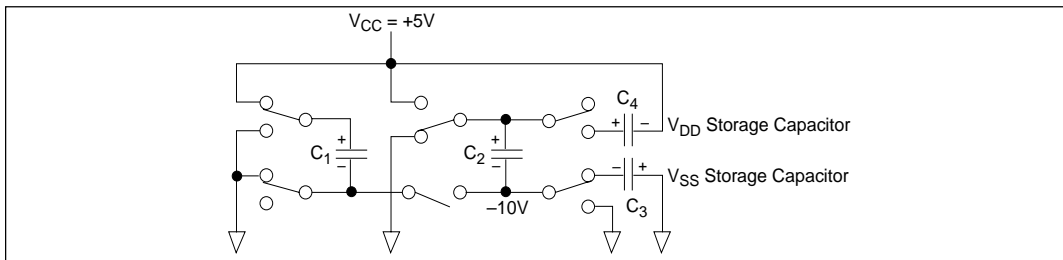

Figure 16. Charge Pump — Phase 2

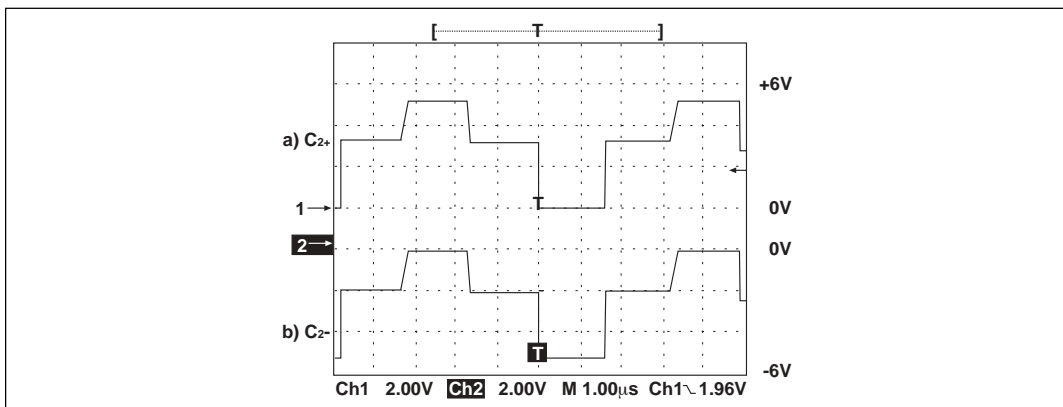

Figure 17. Charge Pump Waveforms

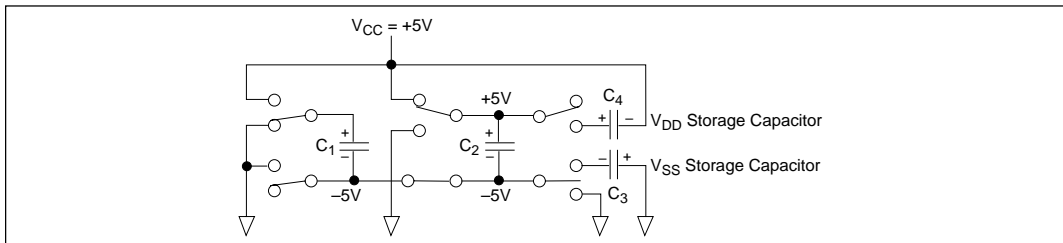

Figure 18. Charge Pump — Phase 3

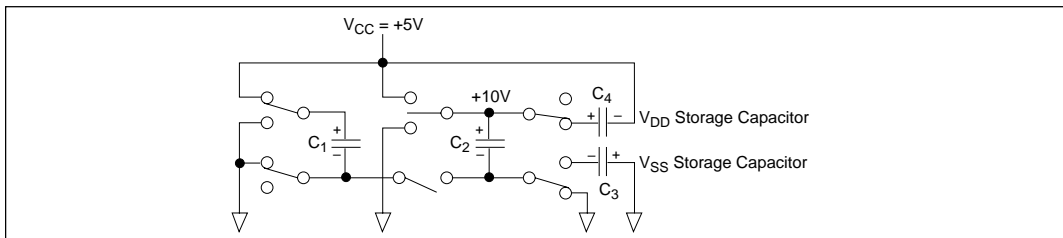

Figure 19. Charge Pump — Phase 4

RS-232 SIGNAL AT RECEIVER INPUT	$\overline{\text{SHUTDOWN}}$ INPUT	$\overline{\text{ONLINE}}$ INPUT	$\overline{\text{STATUS}}$ OUTPUT	TRANSCEIVER STATUS
YES	HIGH	LOW	HIGH	Normal Operation (AUTO ON-LINE®)
NO	HIGH	HIGH	LOW	Normal Operation
NO	HIGH	LOW	LOW	Shutdown (AUTO ON-LINE®)
YES	LOW	HIGH/LOW	HIGH	Shutdown
NO	LOW	HIGH/LOW	LOW	Shutdown

Table 3. AUTO ON-LINE® Logic

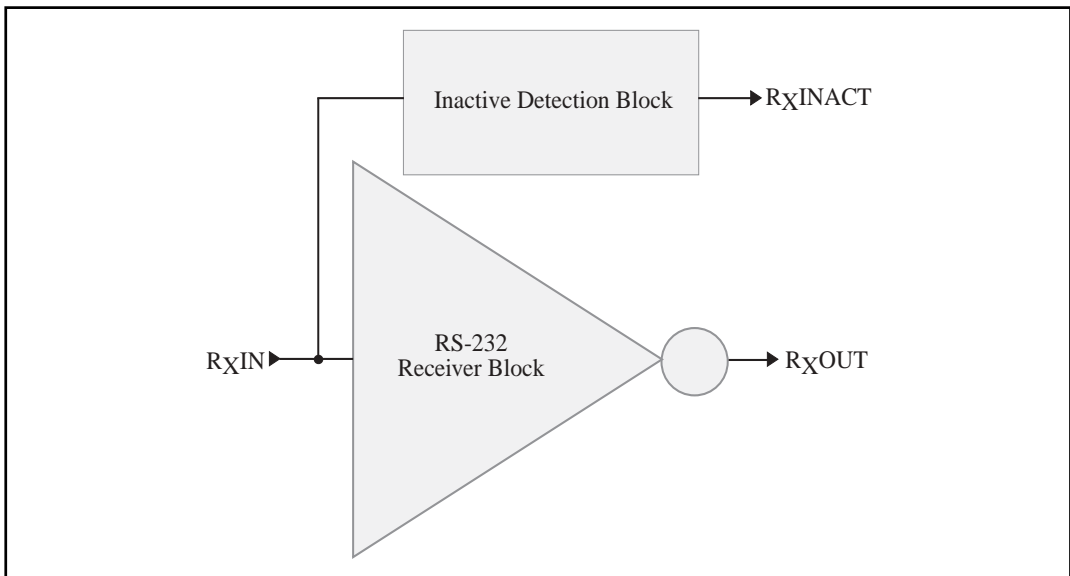

Figure 20. Stage I of AUTO ON-LINE® Circuitry

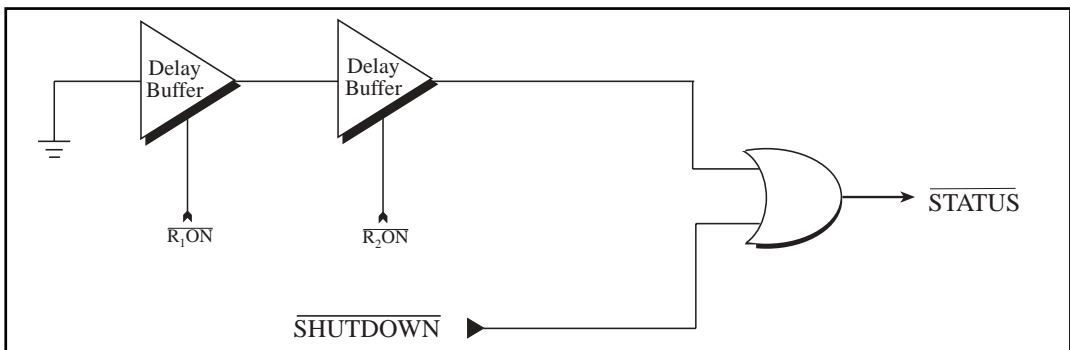

Figure 21. Stage II of AUTO ON-LINE® Circuitry

The Sipex-patented charge pumps are designed to operate reliably with a range of low cost capacitors. Either polarized or non polarized capacitors may be used. If polarized capacitors are used they should be oriented as shown in the Typical Operating Circuit. The V+ capacitor may be connected to either ground or Vcc (polarity reversed.)

The charge pump operates with 0.1µF capacitors for 3.3V operation. For other supply voltages, see the table for required capacitor values. Do not use values smaller than those listed. Increasing the capacitor values (e.g., by doubling in value) reduces

ripple on the transmitter outputs and may slightly reduce power consumption. C2, C3, and C4 can be increased without changing C1's value

For best charge pump efficiency locate the charge pump and bypass capacitors as close as possible to the IC. Surface mount capacitors are best for this purpose. Using capacitors with lower equivalent series resistance (ESR) and self-inductance, along with minimizing parasitic PCB trace inductance will optimize charge pump operation. Designers are also advised to consider that capacitor values may shift over time and operating temperature.

Minimum recommended charge pump capacitor value	
Input Voltage V_{cc}	Charge pump capacitor value for SP32XX
3.0V to 3.6V	C1 – C4 = 0.1µF
4.5V to 5.5V	C1 = 0.047µF, C2-C4 = 0.33µF
3.0V to 5.5V	C1 – C4 = 0.22µF

ESD TOLERANCE

The **SP3223E** series incorporates ruggedized ESD cells on all driver output and receiver input pins. The ESD structure is improved over our previous family for more rugged applications and environments sensitive to electro-static discharges and associated transients. The improved ESD tolerance is at least $\pm 15\text{kV}$ without damage nor latch-up.

There are different methods of ESD testing applied:

- a) MIL-STD-883, Method 3015.7
- b) IEC1000-4-2 Air-Discharge
- c) IEC1000-4-2 Direct Contact

The Human Body Model has been the generally accepted ESD testing method for semiconductors. This method is also specified in MIL-STD-883, Method 3015.7 for ESD testing. The premise of this ESD test is to simulate the human body's potential to store electro-static energy and discharge it to an integrated circuit. The simulation is performed by using a test model as shown in *Figure 22*. This method will test the IC's capability to withstand an ESD transient during normal handling such as in manufacturing areas where the ICs tend to be handled frequently.

The IEC-1000-4-2, formerly IEC801-2, is generally used for testing ESD on equipment and systems. For system manufacturers, they must guarantee a certain amount of ESD protection since the system itself is exposed to the outside environment and human presence. The premise with IEC1000-4-2 is that the system is required to withstand an amount of static electricity when ESD is applied to points and surfaces of the equipment that are accessible to personnel during

normal usage. The transceiver IC receives most of the ESD current when the ESD source is applied to the connector pins. The test circuit for IEC1000-4-2 is shown on *Figure 23*. There are two methods within IEC1000-4-2, the Air Discharge method and the Contact Discharge method.

With the Air Discharge Method, an ESD voltage is applied to the equipment under test (EUT) through air. This simulates an electrically charged person ready to connect a cable onto the rear of the system only to find an unpleasant zap just before the person touches the back panel. The high energy potential on the person discharges through an arcing path to the rear panel of the system before he or she even touches the system. This energy, whether discharged directly or through air, is predominantly a function of the discharge current rather than the discharge voltage. Variables with an air discharge such as approach speed of the object carrying the ESD potential to the system and humidity will tend to change the discharge current. For example, the rise time of the discharge current varies with the approach speed.

The Contact Discharge Method applies the ESD current directly to the EUT. This method was devised to reduce the unpredictability of the ESD arc. The discharge current rise time is constant since the energy is directly transferred without the air-gap arc. In situations such as hand held systems, the ESD charge can be directly discharged to the equipment from a person already holding the equipment. The current is transferred on to the keypad or the serial port of the equipment directly and then travels through the PCB and finally to the IC.

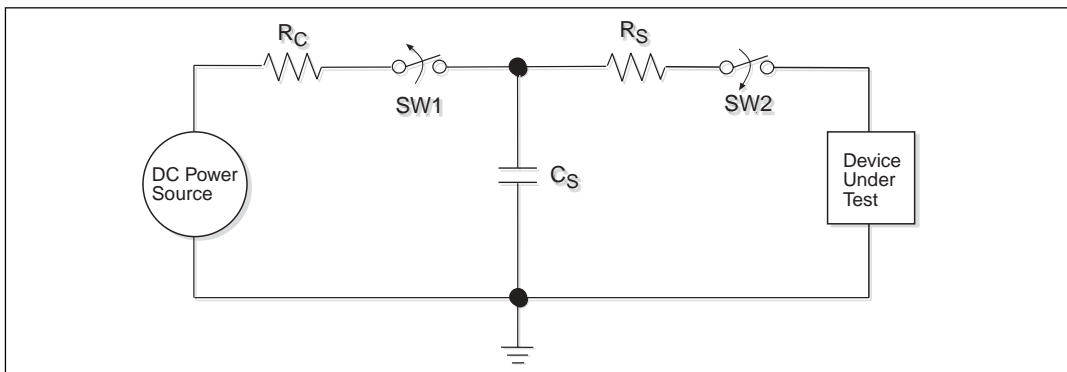

Figure 22. ESD Test Circuit for Human Body Model

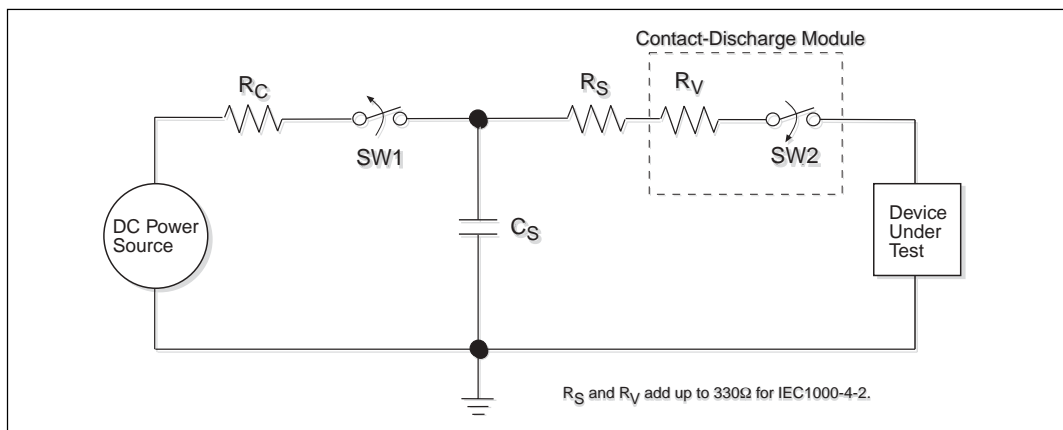

Figure 23. ESD Test Circuit for IEC1000-4-2

The circuit model in Figures 22 and 23 represent the typical ESD testing circuit used for all three methods. The C_S is initially charged with the DC power supply when the first switch (SW1) is on. Now that the capacitor is charged, the second switch (SW2) is on while SW1 switches off. The voltage stored in the capacitor is then applied through R_S , the current limiting resistor, onto the device under test (DUT). In ESD tests, the SW2 switch is pulsed so that the device under test receives a duration of voltage.

For the Human Body Model, the current limiting resistor (R_S) and the source capacitor (C_S) are 1.5kΩ and 100pF, respectively. For IEC-1000-4-2, the current limiting resistor (R_S) and the source capacitor (C_S) are 330Ω and 150pF, respectively.

The higher C_S value and lower R_S value in the IEC1000-4-2 model are more stringent than the Human Body Model. The larger storage capacitor injects a higher voltage to the test point when SW2 is switched on. The lower current limiting resistor increases the current charge onto the test point.

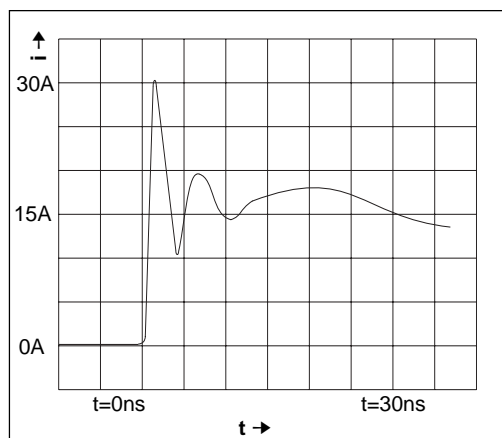
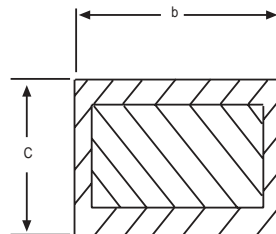
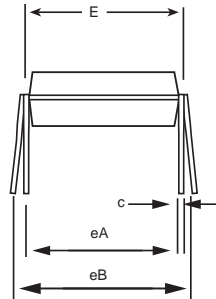
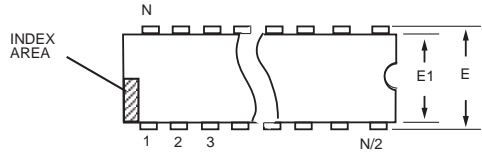
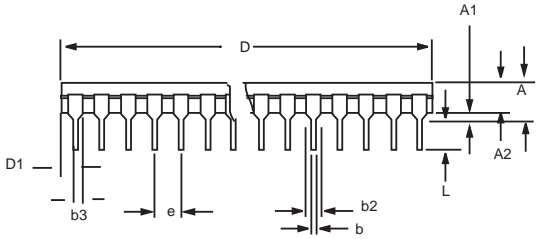

Figure 24. ESD Test Waveform for IEC1000-4-2

DEVICE PIN TESTED	HUMAN BODY MODEL	IEC1000-4-2		
		Air Discharge	Direct Contact	Level
Driver Outputs	±15kV	±15kV	±8kV	4
Receiver Inputs	±15kV	±15kV	±8kV	4

Table 4. Transceiver ESD Tolerance Levels



20 PIN PDIP JEDEC MS-001 (AD) Variation			
SYMBOL	MIN	NOM	MAX
A	-	-	0.21
A1	0.15	-	-
A2	0.115	0.13	0.195
b	0.014	0.018	0.022
b2	0.045	0.06	0.07
b3	0.3	0.039	0.045
c	0.008	0.01	0.014
D	0.98	1.03	1.06
D1	0.005	-	-
E	0.3	0.31	0.325
E1	0.24	0.25	0.28
e	.100 BSC		
eA	.300 BSC		
eB	-	-	0.43
L	0.115	0.13	0.15

Note: Dimensions in (mm)

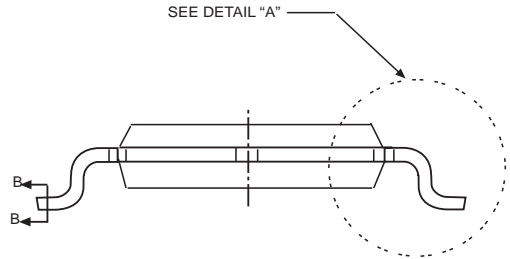
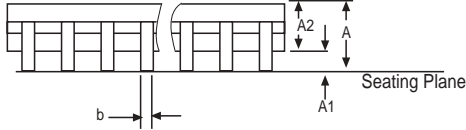
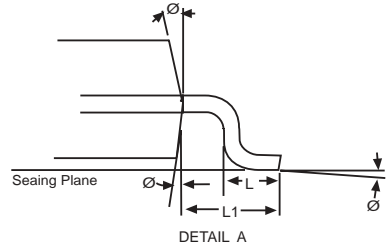
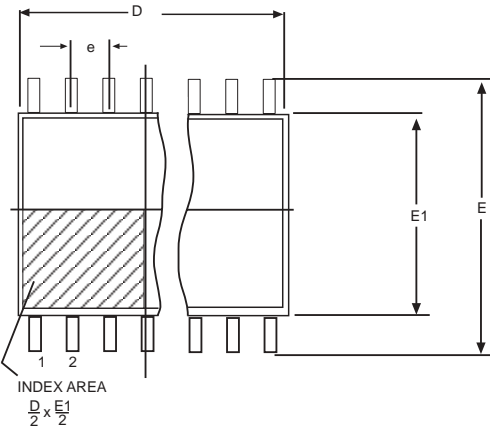

20 Pin TSSOP JEDEC MO-153 (AC) Variation			
SYMBOL	MIN	NOM	MAX
A	-	-	1.2
A1	0.05	-	0.15
A2	0.8	1	1.05
b	0.19	-	0.3
c	0.09	-	0.2
D	6.4	6.5	6.6
E	6.40 BSC		
E1	4.3	4.4	4.5
e	0.65 BSC		
Ø1	0°	-	8°
Ø2	12° REF		
Ø3	12° REF		
L	0.45	0.6	0.75
L1	1.00 REF		

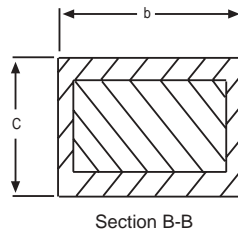

Note: Dimensions in (mm)

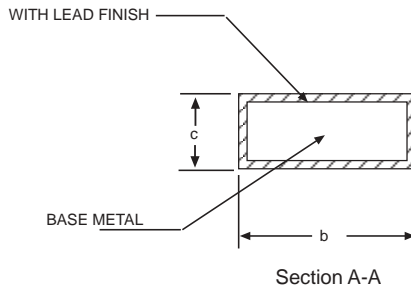
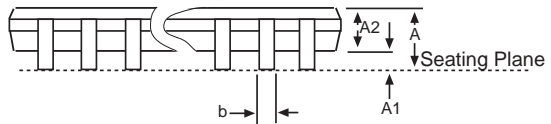
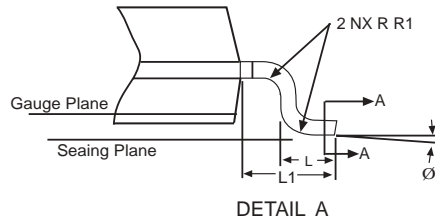
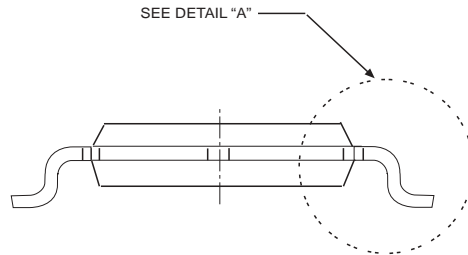
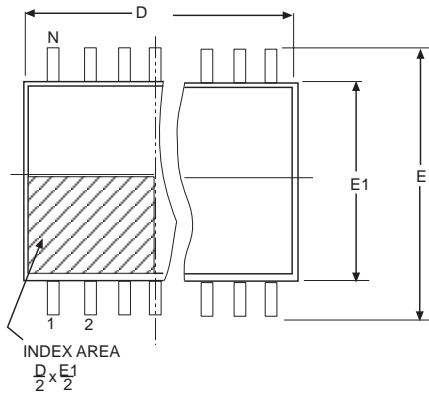

20 Pin SSOP JEDEC MO-153 (AE) Variation			
SYMBOL	MIN	NOM	MAX
A	-	-	2
A1	0.05	-	-
A2	1.65	1.75	1.85
b	0.22	-	0.38
c	0.09	-	0.25
D	6.9	7.2	7.5
E	7.4	7.8	8.2
E1	5	5.3	5.6
L	0.55	0.75	0.95
L1	1.25 REF		
Ø	0°	4°	8°

Note: Dimensions in (mm)

20 PIN SSOP

SP 3223 E U EY-L /TR

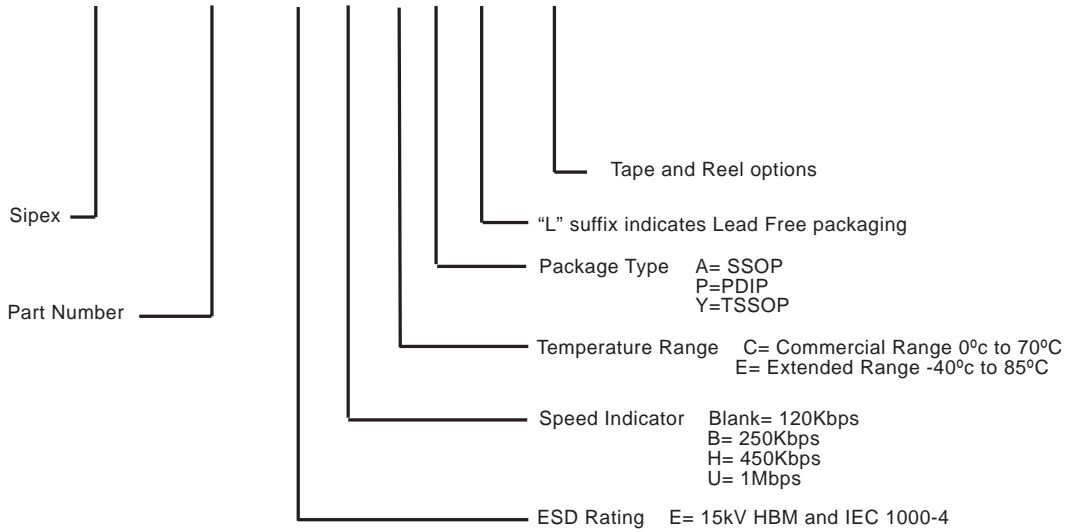

ORDERING INFORMATION

Part Number	Temperature Range	Package Types
SP3223EBCP	0°C to +70°C	20-pin PDIP
SP3223EBCA	0°C to +70°C	20-pin SSOP
SP3223EBCA/TR	0°C to +70°C	20-pin SSOP
SP3223EBCY	0°C to +70°C	20-pin TSSOP
SP3223EBCY/TR	0°C to +70°C	20-pin TSSOP
SP3223EBEP	-40°C to +85°C	20-pin PDIP
SP3223EBEA	-40°C to +85°C	20-pin SSOP
SP3223EBEA/TR	-40°C to +85°C	20-pin SSOP
SP3223EBEY	-40°C to +85°C	20-pin TSSOP
SP3223EBEY/TR	-40°C to +85°C	20-pin TSSOP
SP3223ECA	0°C to +70°C	20-pin SSOP
SP3223ECA/TR	0°C to +70°C	20-pin SSOP
SP3223ECP	0°C to +70°C	20-pin PDIP
SP3223ECY	0°C to +70°C	20-pin TSSOP
SP3223ECY/TR	0°C to +70°C	20-pin TSSOP
SP3223EEA	-40°C to +85°C	20-pin SSOP
SP3223EEA/TR	-40°C to +85°C	20-pin SSOP
SP3223EEP	-40°C to +85°C	20-pin PDIP
SP3223EEY	-40°C to +85°C	20-pin TSSOP
SP3223EEY/TR	-40°C to +85°C	20-pin TSSOP
SP3223EUCP	0°C to +70°C	20-pin PDIP
SP3223EUCA	0°C to +70°C	20-pin SSOP
SP3223EUCA/TR	0°C to +70°C	20-pin SSOP
SP3223EUCY	0°C to +70°C	20-pin TSSOP
SP3223EUCY/TR	0°C to +70°C	20-pin TSSOP
SP3223EUEP	-40°C to +85°C	20-pin PDIP
SP3223EUEA	-40°C to +85°C	20-pin SSOP
SP3223EUEA/TR	-40°C to +85°C	20-pin SSOP
SP3223EUEY	-40°C to +85°C	20-pin TSSOP
SP3223EUEY/TR	-40°C to +85°C	20-pin TSSOP

Available in lead free packaging. To order add "-L" suffix to part number.

Example: SP3223EUEY/TR = standard; SP3223EUEY-L/TR = lead free

/TR = Tape and Reel

Pack quantity is 1,500 for SSOP, TSSOP and WSOIC.

[CLICK HERE TO ORDER SAMPLES](#)

ORDERING INFORMATION

Contact factory for availability of the following legacy part numbers. For long term availability Sipex recommends upgrades as listed below. All upgrade part numbers shown are fully pinout and function compatible with legacy part numbers. Upgrade part numbers may contain feature and/or performance enhancements or other changes to datasheet parameters.

Legacy Part Number	Recommended Upgrade	Legacy Part Number	Recommended Upgrade
SP3223BCA	SP3223EBCA	SP3223EHCY	SP3223EUCY
SP3223BCA/TR	SP3223EBCA/TR	SP3223EHCY/TR	SP3223EUCY/TR
SP3223BCA-L	SP3223EBCA-L	SP3223EHCY-L	SP3223EUCY-L
SP3223BCA-L/TR	SP3223EBCA-L/TR	SP3223EHCY-L/TR	SP3223EUCY-L/TR
SP3223BCP	SP3223EBCP	SP3223EP	SP3223EEP
SP3223BCY	SP3223EBCY	SP3223EY	SP3223EEY
SP3223BCY/TR	SP3223EBCY/TR	SP3223EY/TR	SP3223EEY/TR
SP3223BCY-L	SP3223EBCY-L	SP3223EY-L	SP3223EEY-L
SP3223BCY-L/TR	SP3223EBCY-L/TR	SP3223EY-L/TR	SP3223EEY-L/TR
SP3223BEA	SP3223EBEA	SP3223HCA	SP3223EUCA
SP3223BEA/TR	SP3223EBEA/TR	SP3223HCA/TR	SP3223EUCA/TR
SP3223BEA-L	SP3223EBEA-L	SP3223HCA-L	SP3223EUCA-L
SP3223BEA-L/TR	SP3223EBEA-L/TR	SP3223HCA-L/TR	SP3223EUCA-L/TR
SP3223BEP	SP3223EBEP	SP3223HCP	SP3223EUCP
SP3223BEY	SP3223EBEY	SP3223HCY	SP3223EUCY
SP3223BEY/TR	SP3223EBEY/TR	SP3223HCY/TR	SP3223EUCY/TR
SP3223BEY-L	SP3223EBEY-L	SP3223HCY-L	SP3223EUCY-L
SP3223BEY-L/TR	SP3223EBEY-L/TR	SP3223HCY-L/TR	SP3223EUCY-L/TR
SP3223CA	SP3223ECA	SP3223UCA	SP3223EUCA
SP3223CA/TR	SP3223ECA/TR	SP3223UCA/TR	SP3223EUCA/TR
SP3223CA-L	SP3223ECA-L	SP3223UCA-L	SP3223EUCA-L
SP3223CA-L/TR	SP3223ECA-L/TR	SP3223UCA-L/TR	SP3223EUCA-L/TR
SP3223CP	SP3223ECP	SP3223UCP	SP3223EUCP
SP3223CY	SP3223ECY	SP3223UCY	SP3223EUCY
SP3223CY/TR	SP3223ECY/TR	SP3223UCY/TR	SP3223EUCY/TR
SP3223CY-L	SP3223ECY-L	SP3223UCY-L	SP3223EUCY-L
SP3223CY-L/TR	SP3223ECY-L/TR	SP3223UCY-L/TR	SP3223EUCY-L/TR
SP3223EA	SP3223EEA	SP3223UEA	SP3223EUEA
SP3223EA/TR	SP3223EEA/TR	SP3223UEA/TR	SP3223EUEA/TR
SP3223EA-L	SP3223EEA-L	SP3223UEA-L	SP3223EUEA-L
SP3223EA-L/TR	SP3223EEA-L/TR	SP3223UEA-L/TR	SP3223EUEA-L/TR
SP3223EHCA	SP3223EUCA	SP3223UEP	SP3223EUEP
SP3223EHCA/TR	SP3223EUCA/TR	SP3223UEY	SP3223EUEY
SP3223EHCA-L	SP3223EUCA-L	SP3223UEY/TR	SP3223EUEY/TR
SP3223EHCA-L/TR	SP3223EUCA-L/TR	SP3223UEY-L	SP3223EUEY-L
SP3223EHCP	SP3223EUCP	SP3223UEY-L/TR	SP3223EUEY-L/TR

Sipex Corporation reserves the right to make changes to any products described herein. Sipex does not assume any liability arising out of the application or use of any product or circuit described hereing; neither does it convey any license under its patent rights nor the rights of others.