

REVISIONS

DCP #	REV	DESCRIPTION	DRAWN	DATE	CHECKD	DATE	APPRVD	DATE
2022	A	RELEASED	JN	1/07/09	JWM	1/07/09	JWM	1/07/09

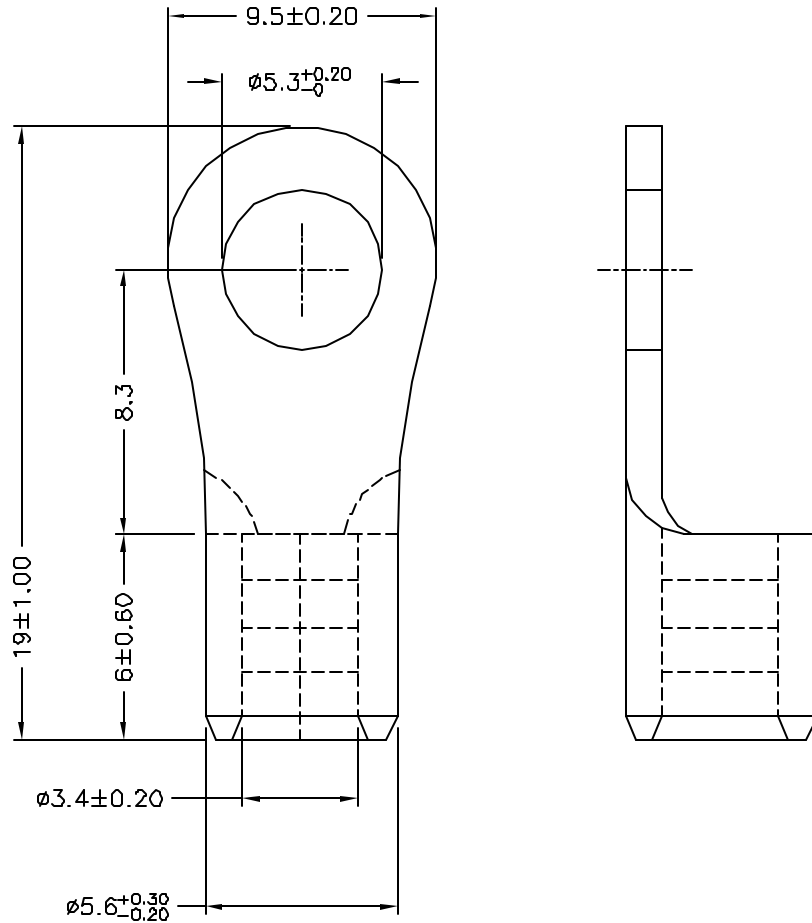

NOTE:

1. MAXIMUM ELECTRIC CURRENT: $\frac{\text{A.W.G.}}{\text{AMP.}}$

12	10		
35	50		
2. WIRE RANGE: 12-10 A.W.G (4-6 mm²)
3. TERMINAL SURFACE TREATMENT: NICKEL PLATED
4. TERMINAL THICKNESS: 1.00mm

DISCLAIMER:
ALL STATEMENTS AND TECHNICAL INFORMATION CONTAINED HEREIN ARE BASED UPON INFORMATION AND/OR TESTS WE BELIEVE TO BE ACCURATE AND RELIABLE. SINCE CONDITIONS OF USE ARE BEYOND OUR CONTROL, THE USER SHALL DETERMINE THE SUITABILITY OF THE PRODUCT FOR THE INTENDED USE AND ASSUME ALL RISK AND LIABILITY WHATSOEVER IN CONNECTION THEREWITH.

TOLERANCES:
UNLESS OTHERWISE SPECIFIED, DIMENSIONS ARE FOR REFERENCE PURPOSES ONLY.

DRAWN BY:	DATE:
Jason Nash	1/07/09
CHECKED BY:	DATE:
Jeff McVicker	1/07/09
APPROVED BY:	DATE:
Jeff McVicker	1/07/09

DRAWING TITLE:			
Terminal			
SIZE	DWG. NO.	ELECTRONIC FILE	REV
A	MC29501	34P2259.dwg	A
SCALE: NTS	U.O.M.: INCHES [mm]	SHEET: 1 OF 1	