

STANDARD COAXIAL CONNECTORS



BNC 75 HDTV series

RADIALL 
The next conneXion

COMPANY PROFILE

Radiall was founded in 1952 as a family owned company making coaxial plugs for the television industry. Today, Radiall is an international and global manufacturer of interconnect components including RF coaxial connectors and cable assemblies, antennas, fiber optic and microwave components, and multipin connectors. Radiall serves the Aerospace, Automotive, Defense, Industrial, Medical, Space, and Telecommunication industries.

QSE (Quality Safety Environment) POLICY

Radiall maintains a quality management system that is highly recognized by its customers because it conforms to most international standards, including those for environmental protection.



Since 1994, all Radiall sites are ISO9001 certified. As a result of Radiall's continuous improvement efforts, some dedicated activities are certified to either AS9100, or TS 16949 or ISO14001. Certain product lines are MIL ESA/SCC Qualified products.

Radiall also complies with other industry directives such as RoHS for hazardous substance restrictions and EuP for environmentally friendly designs for energy-consuming products.



A WORLDWIDE ENGINEERING & MANUFACTURING CAPABILITY



Technical information and sales contacts are available at : www.radiall.com

With expertise centers and manufacturing locations in 3 continents and 12 industrial sites, Radiall offers its customers the proximity needed to provide the best quality, service and delivery performance.

Our facilities feature state of the art equipment for the many technologies involved in the design, manufacturing and assembly of interconnect solutions. Manufacturing plants based in low cost countries give Radiall the opportunity to offer quality at competitive prices.

	Page
Introduction	4
Interface	5
Characteristics	6
Plugs	7
Jacks	7
Receptacles	8
In series adapters	8
Panel drilling	9
Accessories	9
Tooling	9-10
Assembly instructions	11-14
Part number index	15

INTRODUCTION

RADIALL INTRODUCES « TRUE » 75 Ω BNC CONNECTORS FOR THE BROADCAST INDUSTRY

The evolution from the analog TV to higher quality video systems (HDTV) has created an increasing need for improved connector and cable assembly performances.

As one of the leading suppliers of interconnect components and cable assemblies, Radiall addresses the needs with their new line of « True » 75 Ω BNC connectors. Radiall's 75 Ω BNC connectors are specifically designed to handle higher data rates up to 3 Gbps with optimized working frequency range at 3 GHz and working range up to 6 GHz.

FEATURES and BENEFITS

- 75 Ω, optimized electrical performance at 3 GHz, ideal for HDTV signal transmission,
- **Standard bayonet coupling system,**
- **Intermateable with industry standard 50 Ω and 75 Ω BNC connectors,**
- **1000 mating cycles guaranteed,**
- Wide range of PCB and cable configurations,
- Compatible with popular 75 Ω HDTV coaxial cables,
- Colored boots are available for easy coding.

APPLICATIONS

Radiall's « True » 75 Ω BNC connector range is tailored for use in broadcast studios and broadcast transmission systems, such as cameras, video recorders, routers, switching and control systems.



Other applications include: satellite transceivers, aircraft audio systems and test instrumentation.

JACK

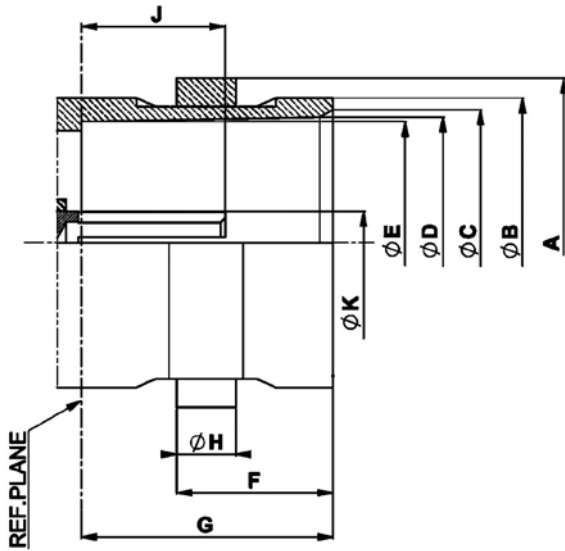

PLUG

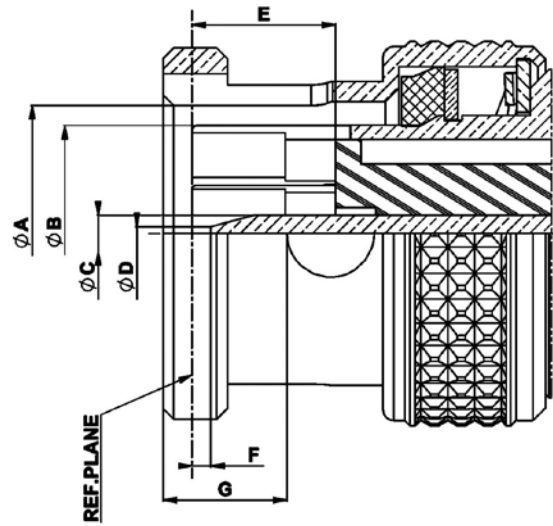

	mm		inch	
	min	max	min	max
A	10.97	11.07	.432	.436
B	9.60	9.67	.378	.381
C	8.80	9.00	.346	.354
D	8.32	8.46	.328	.333
E	8.10	8.15	.319	.321
F	5.18	5.28	.204	.208
G	8.30	8.50	.327	.335
H	1.90	2.06	.075	.081
J	4.72	5.22	.186	.206
K	2.10	2.14	.083	.084

	mm		inch	
	min	max	min	max
A	9.80	9.90	.386	3.90
B	8.30	8.40	.327	.331
C	1.32	1.37	.052	.054
D	0.35	0.65	.014	.026
E	5.30	5.50	.209	.217
F	0.10	0.90	.004	.035
G	4.57	4.67	.180	.184

ELECTRICAL CHARACTERISTICS

Frequency range	DC-6 GHz (optimized at 3 GHz)		
Impedance	75 Ω		
VSWR (max)	DC-1.5 GHz	1.5-3 GHz	3-6 GHz
Interface (Plug + Jack)	1.02	1.05	1.08
Mated pair	1.05	1.12	1.25
In series adapters	1.04	1.07	1.12
Working voltage	500 Vrms		
Dielectric withstanding voltage	1500 Vrms		
RF Leakage @ 1 GHz	75 dB		
RF Leakage @ 3 GHz	60 dB		
RF Leakage @ 6 GHz	50 dB		

MECHANICAL CHARACTERISTICS

Mating	Intermateable with 50 Ω and 75 Ω standard BNC connectors
Long life duration (mating endurance)	1000 cycles
Engagement force	13.6 N
Mating torque (bayonet)	28.6 N.cm
Coupling nut retention force	Axial force : 450 N
	Bending stress : 1000 N.cm
Center contact insertion force	10 N max
Vibration	MIL STD 202 Meth.204 cond B

ENVIRONMENTAL CHARACTERISTICS

Temperature range	-65/+165°C
Moisture resistance	MIL STD 202 Meth. 106 CECC 22000 paragraph 4.6.6
Corrosion resistance	MIL STD 202 Meth.101 cond B (48 hours salt spray)

MATERIAL

Components	Materials	Plating
Body	Brass	NPGR*/BBR**/Nickel
Center contact	Brass or Beryllium copper	NPGR*
Outer contact	Brass	NPGR*
Insulator	PTFE	
Gasket	Silicone rubber	

* NPGR : Nickel Phosphorous Gold Radiall.

** BBR : Bright Bronze Radiall.

All dimensions are given in mm (inch)

STRAIGHT PLUGS CRIMP TYPE FOR FLEXIBLE CABLES

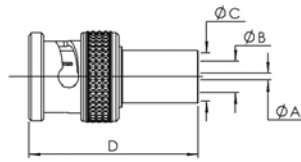

Cable group	Part Number	Dimensions mm (inch)				Assembly instructions	Packaging
		A	B	C	D		
0.6/2.8	R142 077 702	0.85 (.03)	2.85 (.11)	5.42 (.21)	27.68 (1.09)	M01	100
0.6/2.95	R142 077 712		3.00 (.12)				
0.8/3.7	R142 077 722		3.75 (.15)	6.60 (.26)			
1.0/4.8	R142 077 732	1.05 (.04)	4.85 (.19)	7.50 (.30)			

RIGHT ANGLE PLUG CRIMP TYPE FOR FLEXIBLE CABLE

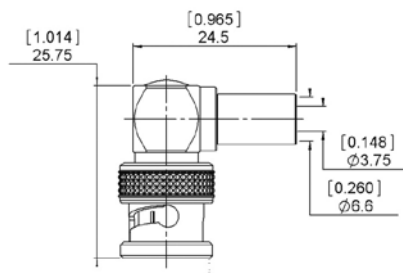

Cable group	Part Number	Assembly instructions	Packaging
0.8/3.7	R142 187 720	M03	100

STRAIGHT BULKHEAD JACK CRIMP TYPE FOR FLEXIBLE CABLE

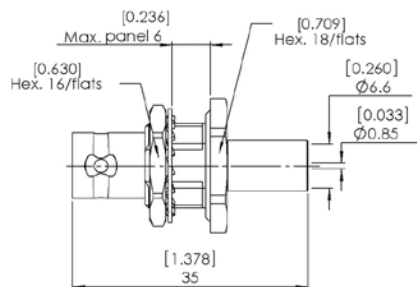

Cable group	Part Number	Assembly instructions	Panel drilling	Packaging
0.8/3.7	R142 334 700	M03	P02	100

For unit packaging add « W » after the P/N.

RECEPTACLES & ADAPTERS

STRAIGHT PCB FEMALE RECEPTACLE

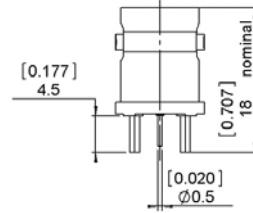
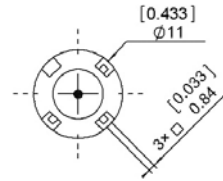

Part Number	Captive center contact	Panel drilling	Packaging
R142 500 730	yes	P01	100

EDGE MOUNT PCB FEMALE RECEPTACLE

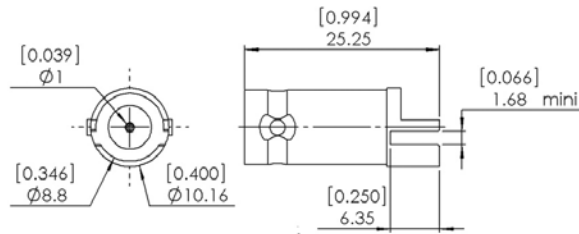

Part Number	Captive center contact	Assembly instructions	Packaging
R142 568 703	yes	M04	100

IN SERIES ADAPTERS

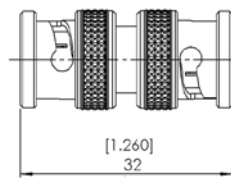

Fig. 1

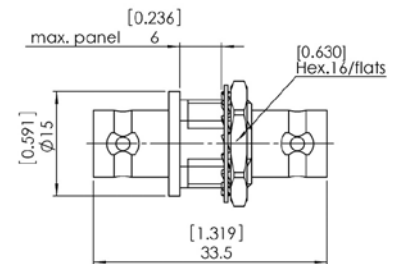

Fig. 2

Part Number	Fig.	Captive center contact	Panel drilling	Note	Packaging
R142 703 703	1	yes	P02	Male-male	100
R142 720 700	2			Female-female	

For unit packaging add « W » after the P/N.

PANEL DRILLING

P01

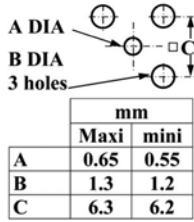

P02

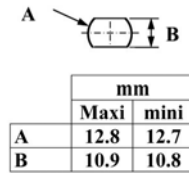

BOOTS (material : PVC)

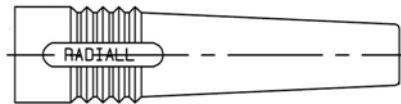

Color	Part Number	
	Cable group 0.6/2.8 - 0.6/2.95	Cable group 0.8/3.7
Black	R280 570 000*	R280 590 000
Red	R280 571 000	R280 591 000
Green	R280 572 000	R280 592 000
Blue	R280 573 000	R280 593 000
Yellow	R280 574 000	R280 594 000
Grey	R280 575 000	R280 595 000
White	R280 576 000	R280 596 000
Brown	R280 577 000	R280 597 000
Orange	R280 578 000	R280 598 000
Violet	R280 579 000	R280 599 000
Nature	R280 580 000	R280 600 000

Standard packaging : 10 pieces. *packaging 100 pieces.

CRIMP TOOL (dies included)

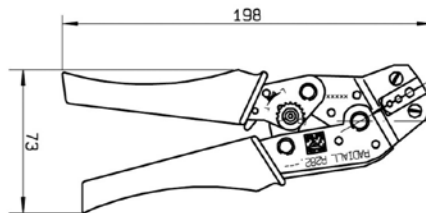

Part Number	Cable group	Color of handles			
R282 223 000	0.6/2.8 - 0.6/2.95 - 0.8/3.7	Orange	6.48 (.255)	5.41 (.213)	1.73 (.068)

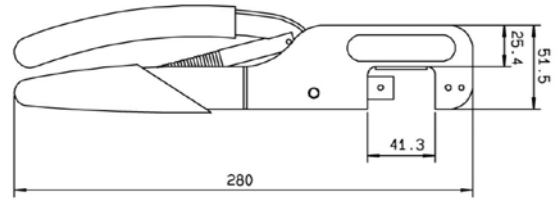

TOOLING

MIL CRIMP TOOL (M22520/5-01) R282 293 000 (dies not included)



DIES



Part Number	Cable group		
R282 235 011	0.6/2.8 - 0.6/2.95	5.41 (.213)	1.73 (.066)
R282 235 013	0.8/3.7	6.48 (.255)	
R282 235 920	1/4.8	6.98 (.275)	
R282 249 000	0.8/3.7 - 0.6/2.8 - 0.6/2.95	6.48 (.255)	5.41 (.213)

CRIMP TOOL FOR CENTER CONTACT R282 281 000

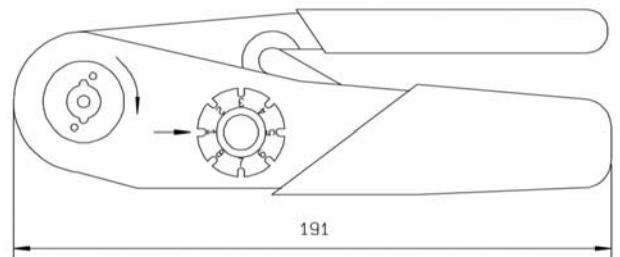

LOCATOR TOOL FOR CENTER CONTACT CRIMP TOOL R282 281 000



Part Number
R282 968 023

M01

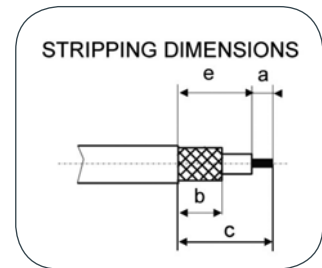
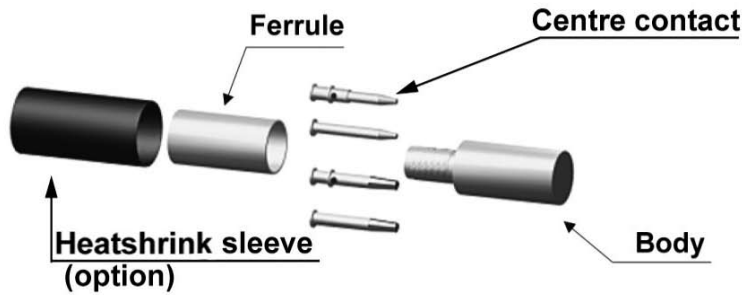

Part Number	Stripping length (mm)			Hex.	Ferrule		Center contact	
	a	b	c		Dies included	MIL standard R282 293 000 (M22520/5-01)+ Dies	R282 281 000 + positioner	
R142 077 702	3.5	10.8	18	5.41	R282 223 000	R282 235 011 (M22520/5-11)	R282 968 023 (pos 6) 2x4 pts	
R142 077 712								
R142 077 722							6.48	R282 235 013 (M22520/5-13) or R282 249 000
R142 077 732	4			6.98		R282 235 920	R282 968 023 (pos 8) 2x4 pts	

- 1**
- Slide the heatshrink sleeve onto the cable (Option).
 - Slide the ferrule onto the cable.
 - Strip the cable.

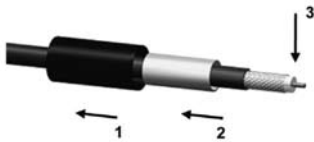

- 2**
- Slide the center contact on until it bottoms against the cable dielectric.
 - Crimp the center contact with crimping tool (see table).



- 3**
- Fan the braid.

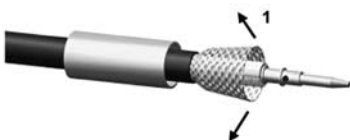

- 4**
- Slide the cable into the body until it bottoms against the insulator.



- 5**
- Slide the ferrule over the braid.
 - Crimp the ferrule with crimping tool (see table).

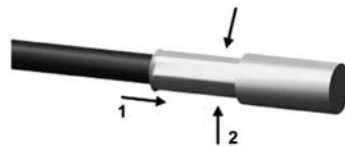

- 6**
- Cut the excess of braid if necessary.
 - Slide the sleeve over the ferrule and heatshrink it in place (Option).

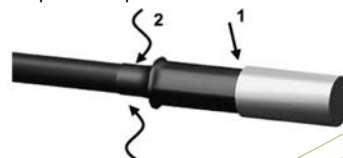

M02

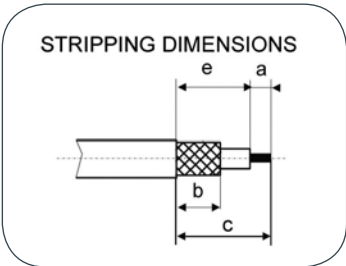
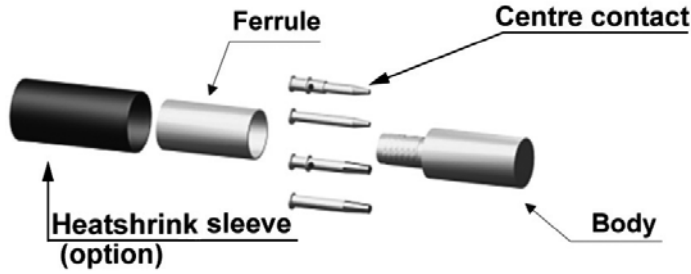

Part Number	Stripping length (mm)				Hex.	Ferrule		Center contact
	a	b	c	e		Dies included	MIL standard R282 293 000 (M22520/5-01) + Dies	R282 281 000 + positioner
R142 334 700	3.3	10.3	16.8	13.5	6.48	R282 223 000	R282 235 013 (M22520/5-13) OR R282 249 000	

- 1**
- Slide the heatshrink sleeve onto the cable (Option).
 - Slide the ferrule onto the cable.
 - Strip the cable.

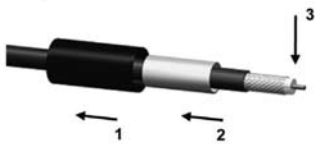

- 2**
- Slide the center contact on until it bottoms against the cable dielectric.
 - Solder the center contact
 - Clean solder area



- 3**
- Fan the braid.

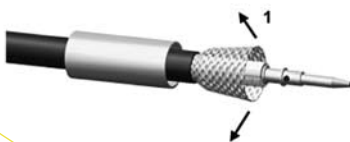

- 4**
- Slide the cable into the body until it bottoms against the insulator.

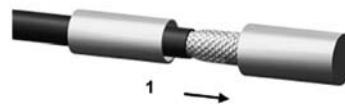

- 5**
- Slide the ferrule over the braid.
 - Crimp the ferrule with crimping tool (see table).

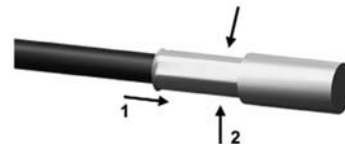

- 6**
- Cut the excess of braid if necessary.
 - Slide the sleeve over the ferrule and heatshrink it in place (Option).

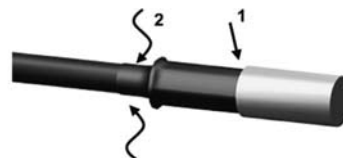

M03

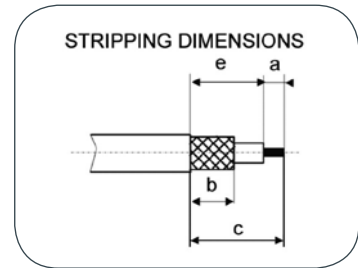
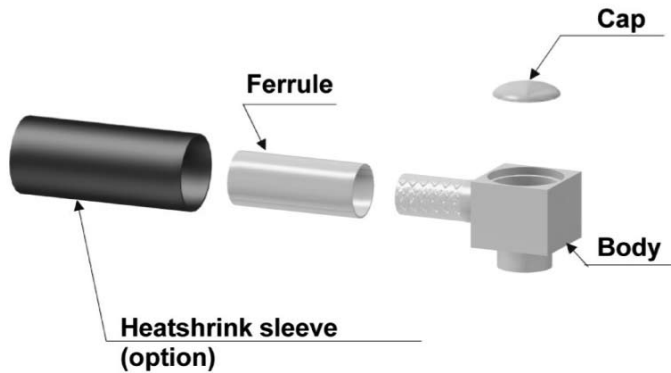

Part Number	Stripping length (mm)				Hex.	Ferrule	
	a	b	c	e		Dies included	MIL standard R282 293 000 (M22520/5-01) + Dies
R142 187 720	2	7.5	16	14	6.48	R282 223 000	R282 235 013 (M22520/5-13) or R282 249 000

- 1**
- Slide the heatshrink sleeve onto the cable (Option).
 - Slide the ferrule onto the cable.
 - Strip the cable.



- 2**
- Fan the braid.



- 3**
- Push the connector body under the braid.
 - Slide the ferrule over the braid.



- 4**
- Crimp the ferrule with crimping tool (see table).
 - Solder the inner conductor

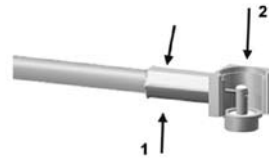

- 5**
- Place the cap into the body.



- 6**
- Press on the cap flush or slightly below the surface of the body assembly.
 - Slide the sleeve over the ferrule and heatshrink it in place (Option).



M04

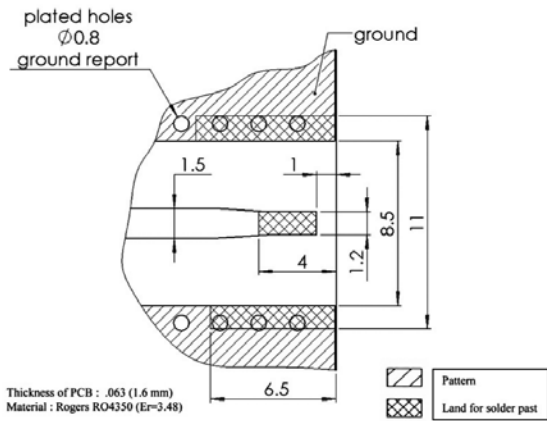

Note: the receptacle and the plug must not be mated before completion of this procedure.

1 Deposit solder paste « Sn Ag4 Cu0.5 » on mounting zone by screen printing application. We recommend a low residue flux.

We advise the thickness of 150 micromm (5.850 microinch). Verify that the edge of the zone is clean.

2 Placement of the receptacle on the mounting zone with an automatic machine of « pick and place » type. A video camera is recommended for positioning of the component. Adhesive agents must not be used on the receptacle.

3 This process of soldering has been tested with convention oven. Below please find the typical profile to use.

4 The cleaning of printed circuit boards is not required.

5 Verification of solder joints and position of the component by visual inspection.

TEMPERATURE PROFILE

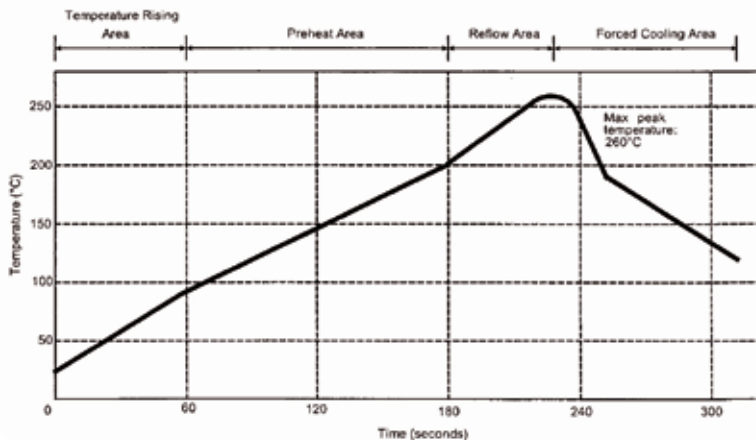

Parameter	Value	Unit
Temperature rising Area	1 - 4	°C/sec
Max Peak Temperature	260	°C
Max dwell time @260°C	10	sec
Min dwell time @235°C	20	sec
Max dwell time @235°C	60	sec
Temperature drop in cooling Area	-1 to -4	°C/sec
Max dwell time above 100°C	420	sec

Part Number	Designation	Page
R142 077 702	Straight plugs crimp type for 0.6/2.8 flexible cable	7
R142 077 712	Straight plugs crimp type for 0.6/2.95 flexible cable	7
R142 077 722	Straight plugs crimp type for 0.8/3.7 flexible cable	7
R142 077 732	Straight plugs crimp type for 1.0/4.8 flexible cable	7
R142 187 720	Right angle plug crimp type for 0.8/3.7 flexible cable	7
R142 334 700	Straight bulkhead jack crimp type for 0.8/3.7 flexible cable	7
R142 500 730	Straight PCB female receptacle	8
R142 568 703	Edge mount PCB female receptacle	8
R142 703 703	In series adapters male-male	8
R142 720 700	In series adapters female-female	8
R280 570 000	Black boot for 0.6/2.8-2.95 cable	9
R280 571 000	Red boot for 0.6/2.8-2.95 cable	9
R280 572 000	Green boot for 0.6/2.8-2.95 cable	9
R280 573 000	Blue boot for 0.6/2.8-2.95 cable	9
R280 574 000	Yellow boot for 0.6/2.8-2.95 cable	9
R280 575 000	Grey boot for 0.6/2.8-2.95 cable	9
R280 576 000	White boot for 0.6/2.8-2.95 cable	9
R280 577 000	Brown boot for 0.6/2.8-2.95 cable	9
R280 578 000	Orange boot for 0.6/2.8-2.95 cable	9
R280 579 000	Violet boot for 0.6/2.8-2.95 cable	9
R280 580 000	Nature boot for 0.6/2.8-2.95 cable	9
R280 590 000	Black boot for 0.8/3.7 cable	9
R280 591 000	Red boot for 0.8/3.7 cable	9
R280 592 000	Green boot for 0.8/3.7 cable	9
R280 593 000	Blue boot for 0.8/3.7 cable	9
R280 594 000	Yellow boot for 0.8/3.7 cable	9
R280 595 000	Grey boot for 0.8/3.7 cable	9
R280 596 000	White boot for 0.8/3.7 cable	9
R280 597 000	Brown boot for 0.8/3.7 cable	9
R280 598 000	Orange boot for 0.8/3.7 cable	9
R280 599 000	Violet boot for 0.8/3.7 cable	9
R280 600 000	Nature boot for 0.8/3.7 cable	9
R282 223 000	Crimp tool	9
R282 235 011	Dies for 0.6/2.8 - 2.95 cable	10
R282 235 013	Dies for 0.8/3.7 cable	10
R282 235 920	Dies for 1/4.8 cable	10
R282 249 000	Dies for 0.8/3.7 - 0.6/2.8 - 0.6/2.95 cable	10
R282 281 000	Crimp tool	10
R282 293 000	Mil crimp tool	10
R282 968 023	Locator tool	10



AEROSPACE



AUTOMOTIVE



DEFENSE



INDUSTRIAL



INSTRUMENTATION



MEDICAL



SPACE



TELECOM

EUROPE

France - RADIALL Headquarters

101, Rue Ph. Hoffmann
93116 ROSNY sous BOIS (Paris)
Tel.: +33 1 49 35 35 35 - Fax: +33 1 48 54 63 63
E-Mail: info@radiall.com

Finland - RADIALL SF

P.O. Box 202 - 90101 OULU
Tel.: +358 407 522 412
E-Mail: infofi@radiall.com

Germany - RADIALL GmbH

Carl-Zeiss Str. 10 Postfach 200143
D63307 - RÖDERMARK (Frankfurt)
Tel.: +49 60 74 91 07 0 - Fax: +49 60 74 91 07 70
E-Mail: infode@radiall.com

Italy - RADIALL Elettronica S.R.L.

Via Concordia, 5 - 20090 ASSAGO MILANO
Tel.: +39 02 48 85 121 - Fax: +39 02 48 84 30 18
E-Mail: infoit@radiall.com
Regional office: Roma

Netherlands - RADIALL B.V.

Hogebrinkerweg 15b - 3871 KM HOEVELAKEN
Tel.: +31 33 253 40 09 - Fax: +31 33 253 45 12
E-Mail: infonl@radiall.com

Sweden - RADIALL A.B.

Sjöängsvägen 2 - SE-192 72 SOLLENTUNA (Stockholm)
Tel.: +46 844 434 10 - Fax: +46 875 449 16
E-Mail: infose@radiall.com

U.K. - RADIALL Ltd

Ground Floor, 6 The Grand Union Office Park,
Packet Boat Lane
UXBRIDGE Middlesex UB8 2GH (London)
Tel.: +44 1895 425 000 - Fax: +44 1895 425 010
E-Mail: infouk@radiall.com

NORTH AMERICA

USA - RADIALL USA, Inc.

6825 West Galveston Street Suite 11
CHANDLER, Arizona 85226
Tel.: +1 480 682 9400 - Fax: +1 480 682 9403
E-Mail: infousa@radiall.com

USA - RADIALL AEP, Inc.

104 John W. Murphy Drive
NEW HAVEN, Connecticut 06513
Tel.: +1 203 776 2813 - Fax: +1 203 776 8294
E-Mail: aepepsales@radiall.com

ALSO REPRESENTED IN

Australia	Hungary	Poland
Austria	Indonesia	Russia
Belgium	Israel	Singapore
Brazil	Korea	Spain
Czech Republic	Latvia	Switzerland
Denmark	Lithuania	Taiwan
Estonia	Malaysia	Thailand
Greece	Norway	Vietnam
	Philippines	South Africa

For the above countries, please contact the local agent or RADIALL at info@radiall.com

ASIA

China - SHANGHAI RADIALL Electronic Co., Ltd

N° 390 Yong He Road 200072 - SHANGHAI
Tel.: +86 21 66 52 37 88 - Fax: +86 21 66 52 11 77
E-Mail: infozh@radiall.com

Japan - NIHON RADIALL

Shibuya-ku Ebisu 1-5-2, Kougetsu Bldg 405
TOKYO 150-0013
Tel.: +81 3 3440 6241 - Fax: +81 3 3440 6242
E-Mail: infojp@radiall.com

HongKong - RADIALL Electronics Ltd

Elite Industrial Centre, Room 212, 2/F
N° 883 Cheung Sha Wan Road
KOWLOON HONG KONG
Tel.: +852 29 59 38 33 - Fax: +852 29 59 26 36
E-Mail: infohk@radiall.com

India - RADIALL PROTECTRON pvt Ltd

25 D, II Phase, Peenya Industrial Area
BANGALORE 560058
Tel.: +91 80 83 95 271 - Fax: +91 80 83 97 228
E-Mail: infoin@radiall.com