

MIXED SIGNAL MICROCONTROLLER

FEATURES

- **Low Supply Voltage Range: 1.8 V to 3.6 V**
- **Ultralow Power Consumption**
 - **Active Mode (AM):**
All System Clocks Active:
270 μ A/MHz at 8 MHz, 3.0 V, Flash Program Execution (Typical)
 - **Standby Mode (LPM3):**
Watchdog With Crystal, and Supply Supervisor Operational, Full RAM Retention, Fast Wake-Up:
1.8 μ A at 2.2 V, 2.1 μ A at 3.0 V (Typical)
 - **Shutdown RTC Mode (LPM3.5):**
Shutdown Mode, Active Real-Time Clock With Crystal:
1.1 μ A at 3.0 V (Typical)
 - **Shutdown Mode (LPM4.5):**
0.3 μ A at 3.0 V (Typical)
- **Wake-Up From Standby Mode in 3 μ s (Typical)**
- **16-Bit RISC Architecture, Extended Memory, up to 20-MHz System Clock**
- **Flexible Power Management System**
 - **Fully Integrated LDO With Programmable Regulated Core Supply Voltage**
 - **Supply Voltage Supervision, Monitoring, and Brownout**
- **Unified Clock System**
 - **FLL Control Loop for Frequency Stabilization**
 - **Low-Power/Low-Frequency Internal Clock Source (VLO)**
 - **Low-Frequency Trimmed Internal Reference Source (REFO)**
 - **32-kHz Crystals (XT1)**
 - **High-Frequency Crystals Up to 32 MHz (XT2)**
- **Four 16-Bit Timer With 3, 5, or 7 Capture/Compare Registers**
- **Two Universal Serial Communication Interfaces**
 - **USCI_A0 and USCI_A1 Each Supporting**
 - **Enhanced UART Supporting Auto-Baudrate Detection**
 - **IrDA Encoder and Decoder**
 - **Synchronous SPI**
 - **USCI_B0 and USCI_B1 Each Supporting**
 - **I²C™**
 - **Synchronous SPI**
- **Full-Speed Universal Serial Bus (USB)**
 - **Integrated USB-PHY**
 - **Integrated 3.3-V/1.8-V USB Power System**
 - **Integrated USB-PLL**
 - **Eight Input, Eight Output Endpoints**
- **12-Bit Analog-to-Digital (A/D) Converter With Internal Shared Reference, Sample-and-Hold, and Autoscan Feature**
- **Dual 12-Bit Digital-to-Analog (D/A) Converters With Synchronization**
- **Voltage Comparator**
- **Integrated LCD Driver With Contrast Control for up to 160 Segments**
- **Hardware Multiplier Supporting 32-Bit Operations**
- **Serial Onboard Programming, No External Programming Voltage Needed**
- **Six-Channel Internal DMA**
- **Real-Time Clock Module With Supply Voltage Backup Switch**
- **Family Members are Summarized in [Table 1](#)**
- **For Complete Module Descriptions, See the *MSP430x5xx/MSP430x6xx Family User's Guide (SLAU208)***



Please be aware that an important notice concerning availability, standard warranty, and use in critical applications of Texas Instruments semiconductor products and disclaimers thereto appears at the end of this data sheet.

All trademarks are the property of their respective owners.

DESCRIPTION

The Texas Instruments MSP430 family of ultralow-power microcontrollers consists of several devices featuring different sets of peripherals targeted for various applications. The architecture, combined with five low power modes is optimized to achieve extended battery life in portable measurement applications. The device features a powerful 16-bit RISC CPU, 16-bit registers, and constant generators that contribute to maximum code efficiency. The digitally controlled oscillator (DCO) allows wake-up from low-power modes to active mode in 3 μ s (typical).

The MSP430F663x series are microcontroller configurations with a high performance 12-bit analog-to-digital (A/D) converter, comparator, two universal serial communication interfaces (USCI), USB 2.0, hardware multiplier, DMA, four 16-bit timers, real-time clock module with alarm capabilities, LCD driver, and up to 74 I/O pins.

Typical applications for this device include analog and digital sensor systems, digital motor control, remote controls, thermostats, digital timers, hand-held meters, etc.

Family members available are summarized in [Table 1](#).

Table 1. Family Members

Device	Flash (KB)	SRAM (KB) ⁽¹⁾	Timer_A ⁽²⁾	Timer_B ⁽³⁾	USCI		ADC12_A (Ch)	DAC12_A (Ch)	Comp_B (Ch)	I/O	Package Type
					Channel A: UART/IrDA/SPI	Channel B: SPI/I ² C					
MSP430F6638	256	16 + 2	5, 3, 3	7	2	2	12 ext / 4 int	2	12	74	100 PZ, 113 ZQW
MSP430F6637	192	16 + 2	5, 3, 3	7	2	2	12 ext / 4 int	2	12	74	100 PZ, 113 ZQW
MSP430F6636	128	16 + 2	5, 3, 3	7	2	2	12 ext / 4 int	2	12	74	100 PZ, 113 ZQW
MSP430F6635	256	16 + 2	5, 3, 3	7	2	2	12 ext / 4 int	-	12	74	100 PZ, 113 ZQW
MSP430F6634	192	16 + 2	5, 3, 3	7	2	2	12 ext / 4 int	-	12	74	100 PZ, 113 ZQW
MSP430F6633	128	16 + 2	5, 3, 3	7	2	2	12 ext / 4 int	-	12	74	100 PZ, 113 ZQW
MSP430F6632	256	16 + 2	5, 3, 3	7	2	2	-	-	12	74	100 PZ, 113 ZQW
MSP430F6631	192	16 + 2	5, 3, 3	7	2	2	-	-	12	74	100 PZ, 113 ZQW
MSP430F6630	128	16 + 2	5, 3, 3	7	2	2	-	-	12	74	100 PZ, 113 ZQW

- (1) The additional 2 KB USB SRAM that is listed can be used as general purpose SRAM when USB is not in use.
- (2) Each number in the sequence represents an instantiation of Timer_A with its associated number of capture compare registers and PWM output generators available. For example, a number sequence of 3, 5 would represent two instantiations of Timer_A, the first instantiation having 3 and the second instantiation having 5 capture compare registers and PWM output generators, respectively.
- (3) Each number in the sequence represents an instantiation of Timer_B with its associated number of capture compare registers and PWM output generators available. For example, a number sequence of 3, 5 would represent two instantiations of Timer_B, the first instantiation having 3 and the second instantiation having 5 capture compare registers and PWM output generators, respectively.

Table 2. Ordering Information⁽¹⁾

T _A	PACKAGED DEVICES ⁽²⁾	
	PLASTIC 100-PIN TQFP (PZ)	PLASTIC 113-BALL BGA (ZQW)
–40°C to 85°C	MSP430F6638IPZ	MSP430F6638IZQW
	MSP430F6637IPZ	MSP430F6637IZQW
	MSP430F6636IPZ	MSP430F6636IZQW
	MSP430F6635IPZ	MSP430F6635IZQW
	MSP430F6634IPZ	MSP430F6634IZQW
	MSP430F6633IPZ	MSP430F6633IZQW
	MSP430F6632IPZ	MSP430F6632IZQW
	MSP430F6631IPZ	MSP430F6631IZQW
	MSP430F6630IPZ	MSP430F6630IZQW

- (1) For the most current package and ordering information, see the Package Option Addendum at the end of this document, or see the TI web site at www.ti.com.
- (2) Package drawings, standard packing quantities, thermal data, symbolization, and PCB design guidelines are available at www.ti.com/package.

Functional Block Diagram, MSP430F6638, MSP430F6637, MSP430F6636

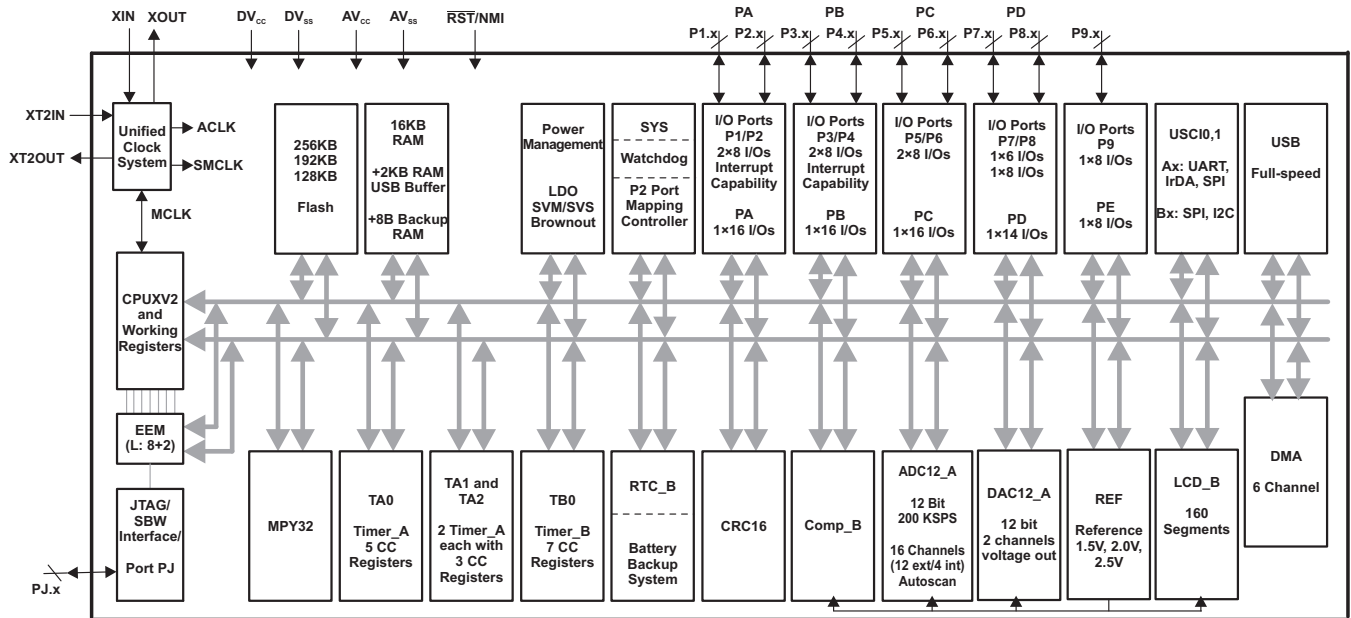

Functional Block Diagram, MSP430F6635, MSP430F6634, MSP430F6633

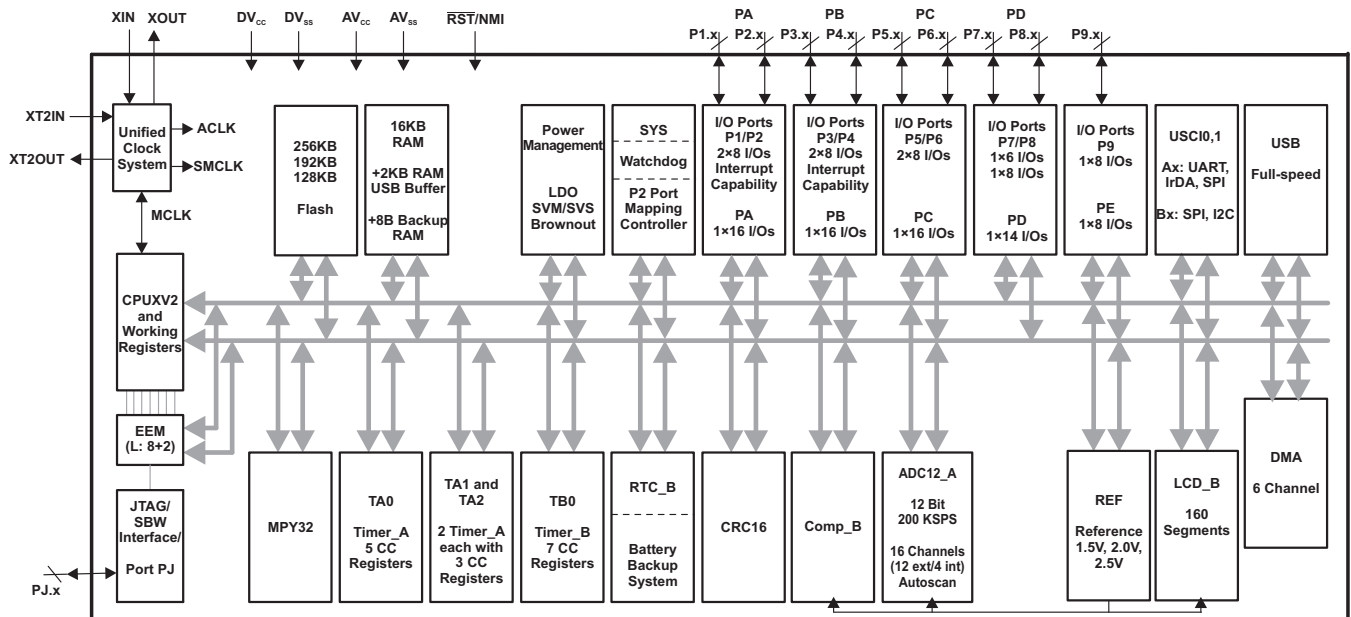

Functional Block Diagram, MSP430F6632, MSP430F6631, MSP430F6630

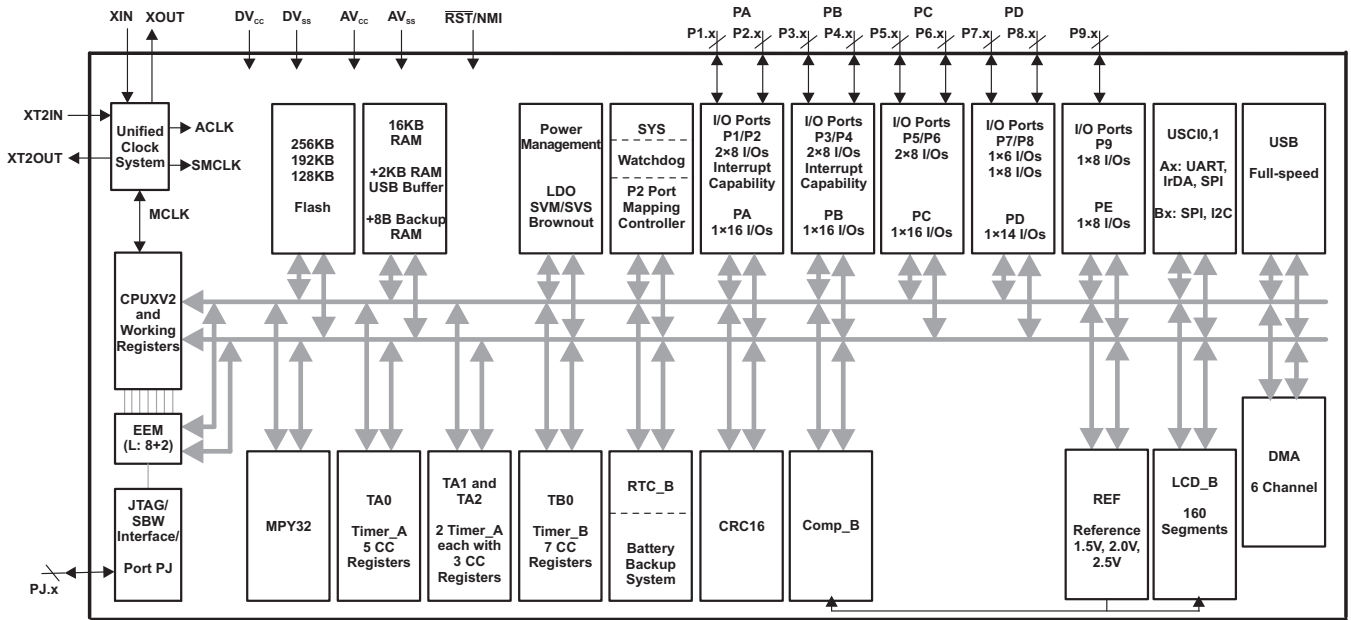

Pin Designation, MSP430F6638IPZ, MSP430F6637IPZ, MSP430F6636IPZ

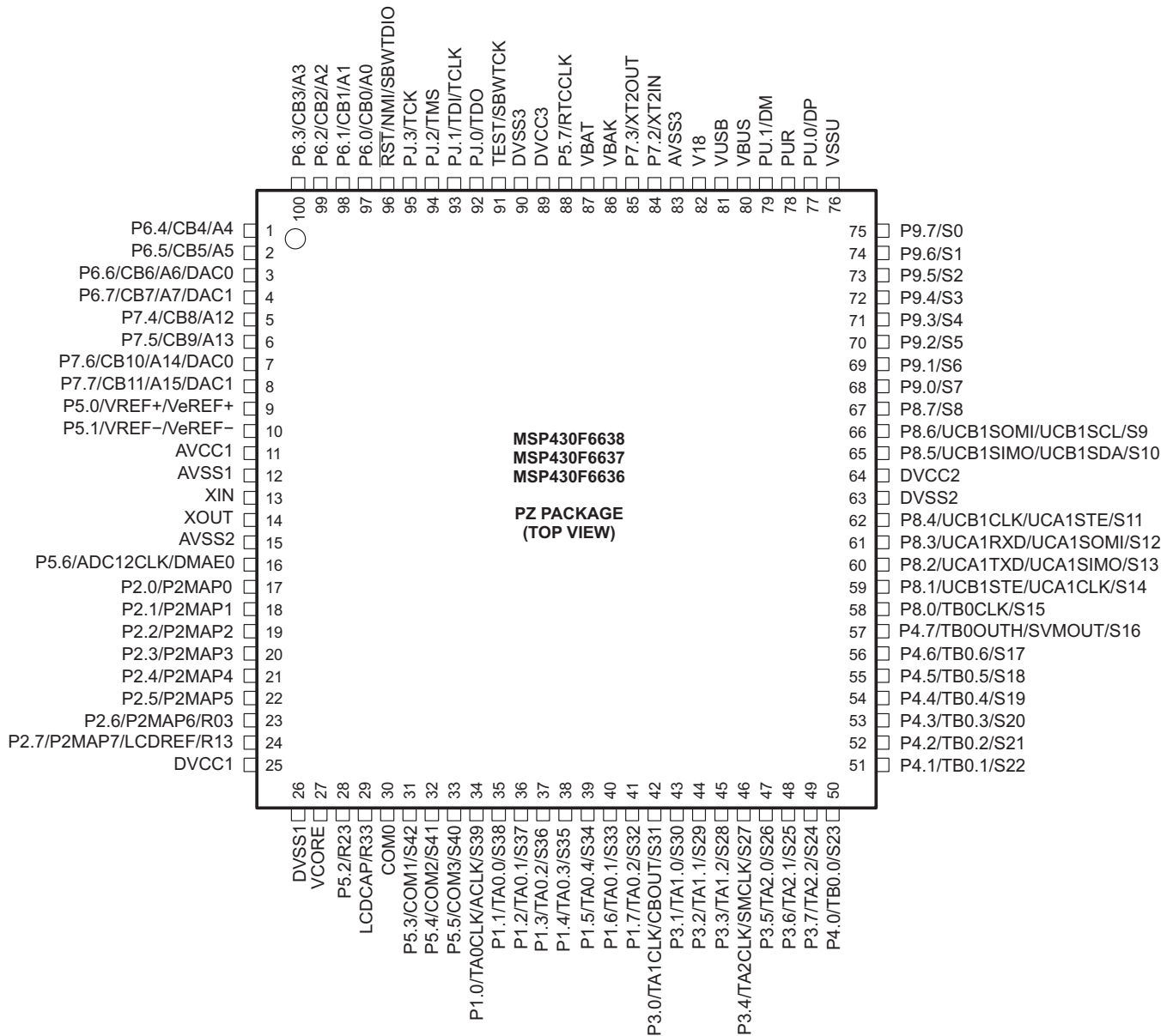

CAUTION: LCDCAP/R33 must be connected to DV_{SS} if not used.

Pin Designation, MSP430F6635IPZ, MSP430F6634IPZ, MSP430F6633IPZ

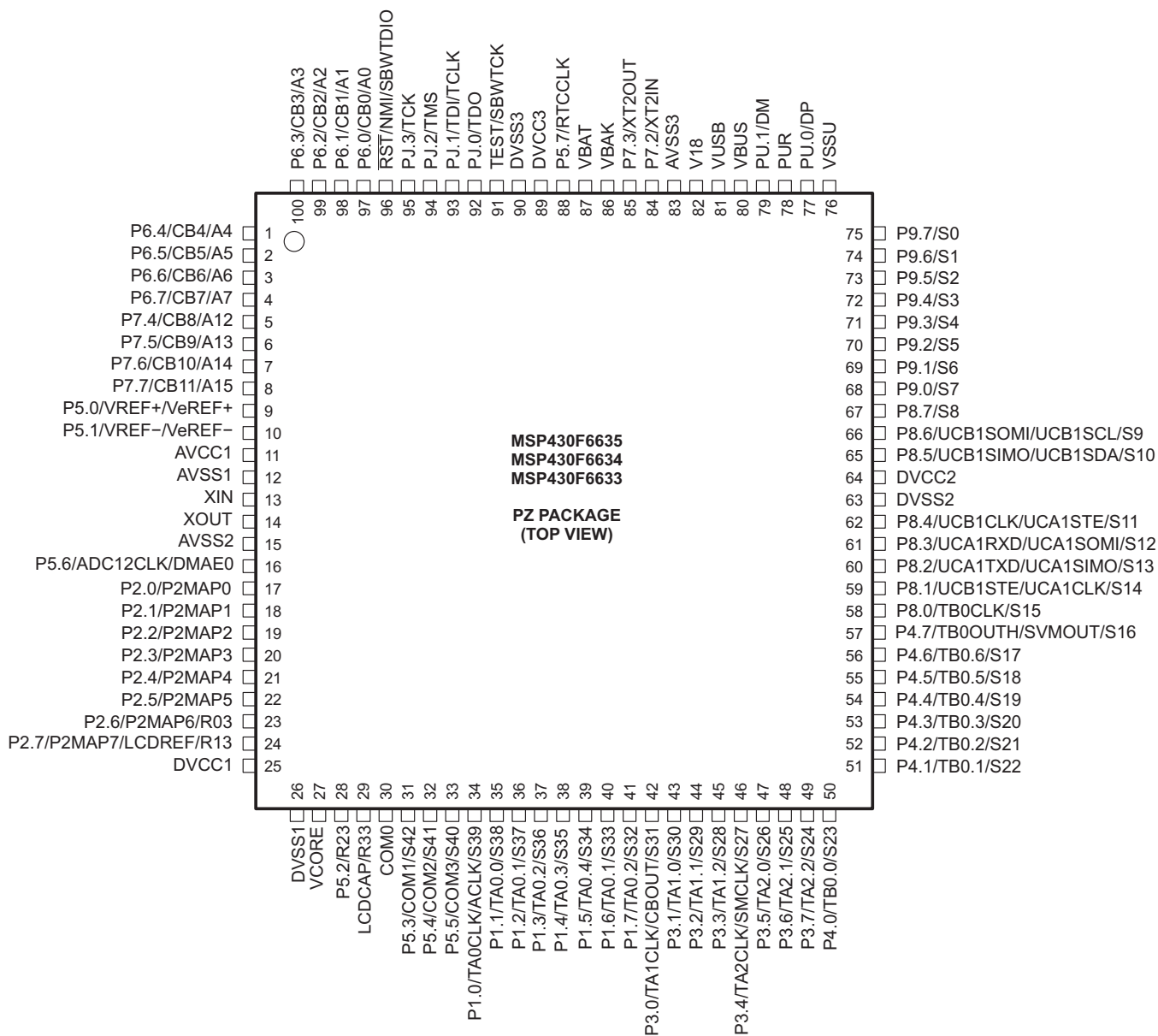

CAUTION: LCDCAP/R33 must be connected to DV_{SS} if not used.

Pin Designation, MSP430F6632IPZ, MSP430F6631IPZ, MSP430F6630IPZ

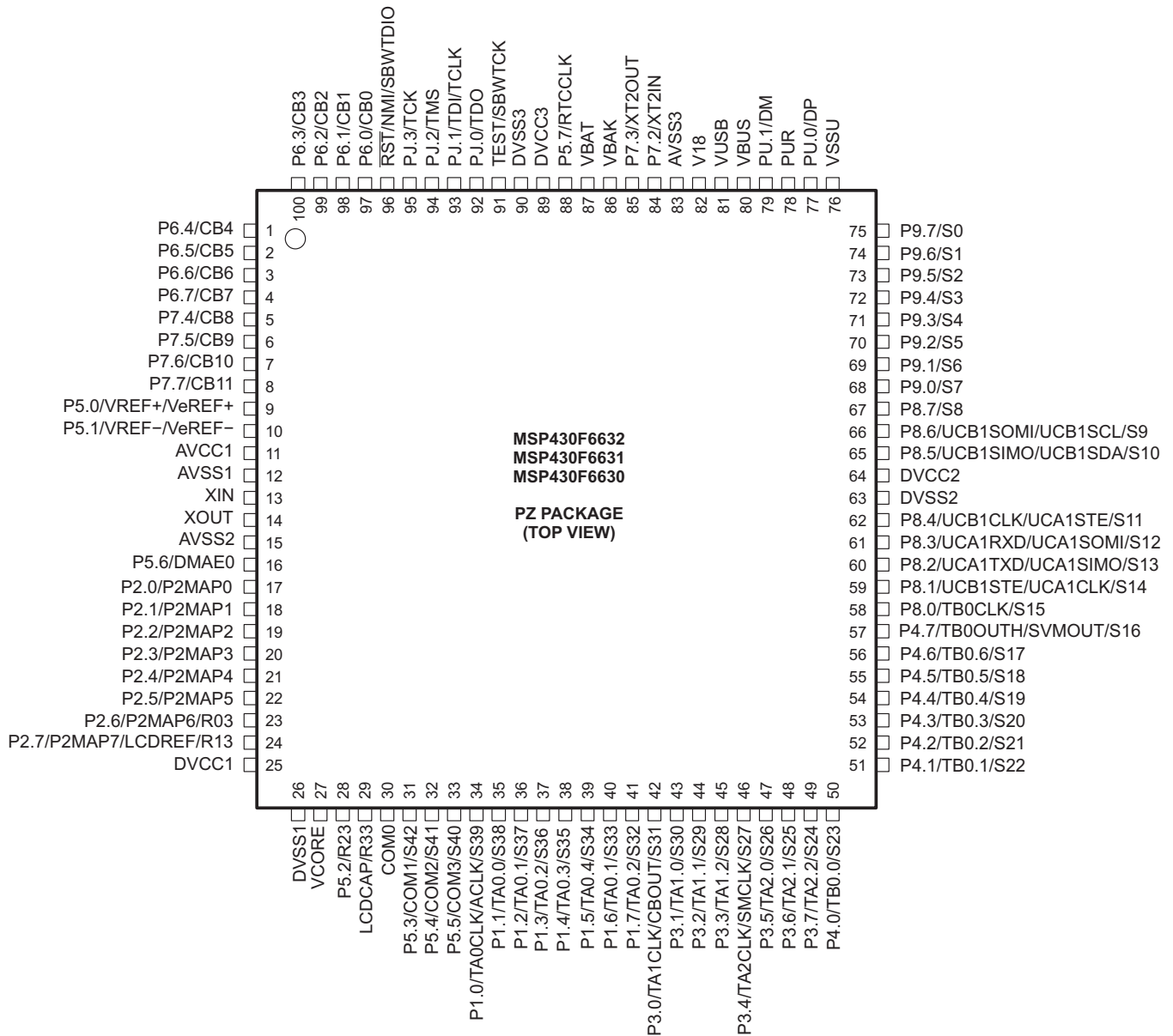

CAUTION: LCDCAP/R33 must be connected to DV_{SS} if not used.

**Pin Designation, MSP430F6638IZQW, MSP430F6637IZQW, MSP430F6636IZQW,
MSP430F6635IZQW, MSP430F6634IZQW, MSP430F6633IZQW, MSP430F6632IZQW,
MSP430F6631IZQW, MSP430F6630IZQW**

**ZQW PACKAGE
(TOP VIEW)**

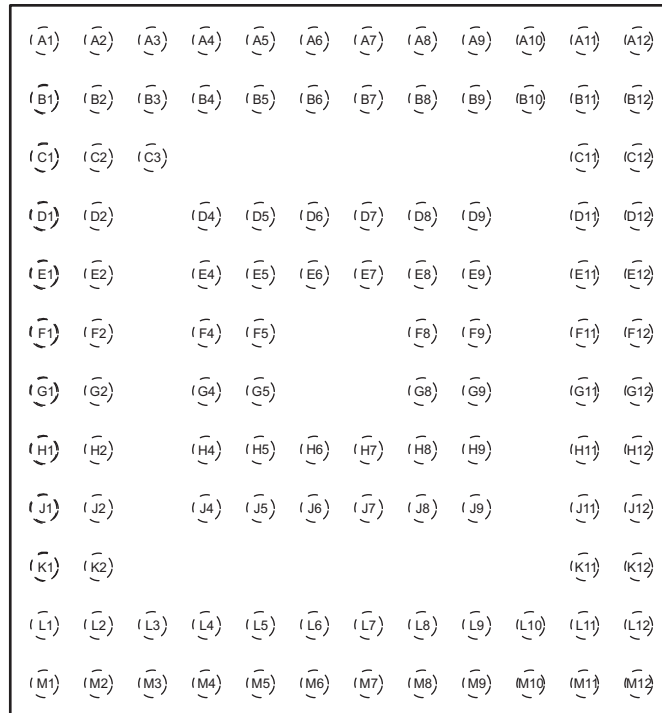

NOTE: For terminal assignments, see [Table 3](#)

Table 3. Terminal Functions

TERMINAL		NO.	I/O ⁽¹⁾	DESCRIPTION	
NAME	PZ				ZQW
P6.5/CB5/A5	2	B2	I/O	General-purpose digital I/O Comparator_B input CB5 Analog input A5 – ADC (not available on '6632, '6631, '6630 devices)	
P6.6/CB6/A6/DAC0	3	B1	I/O	General-purpose digital I/O Comparator_B input CB6 Analog input A6 – ADC (not available on '6632, '6631, '6630 devices) DAC12.0 output (not available on '6635, '6634, '6633, '6632, '6631, '6630 devices)	
P6.7/CB7/A7/DAC1	4	C2	I/O	General-purpose digital I/O Comparator_B input CB7 Analog input A7 – ADC (not available on '6632, '6631, '6630 devices) DAC12.1 output (not available on '6635, '6634, '6633, '6632, '6631, '6630 devices)	
P7.4/CB8/A12	5	C1	I/O	General-purpose digital I/O Comparator_B input CB8 Analog input A12 – ADC (not available on '6632, '6631, '6630 devices)	
P7.5/CB9/A13	6	C3	I/O	General-purpose digital I/O Comparator_B input CB9 Analog input A13 – ADC (not available on '6632, '6631, '6630 devices)	
P7.6/CB10/A14/DAC0	7	D2	I/O	General-purpose digital I/O Comparator_B input CB10 Analog input A14 – ADC (not available on '6632, '6631, '6630 devices) DAC12.0 output (not available on '6635, '6634, '6633, '6632, '6631, '6630 devices)	
P7.7/CB11/A15/DAC1	8	D1	I/O	General-purpose digital I/O Comparator_B input CB11 Analog input A15 – ADC (not available on '6632, '6631, '6630 devices) DAC12.1 output (not available on '6635, '6634, '6633, '6632, '6631, '6630 devices)	
P5.0/VREF+/VeREF+	9	D4	I/O	General-purpose digital I/O Output of reference voltage to the ADC Input for an external reference voltage to the ADC	
P5.1/VREF-/VeREF-	10	E4	I/O	General-purpose digital I/O Negative terminal for the ADC's reference voltage for both sources, the internal reference voltage, or an external applied reference voltage	
AVCC1	11	E1, E2		Analog power supply	
AVSS1	12	F2		Analog ground supply	
XIN	13	F1	I	Input terminal for crystal oscillator XT1	
XOUT	14	G1	O	Output terminal of crystal oscillator XT1	
AVSS2	15	G2		Analog ground supply	
P5.6/ADC12CLK/DMAE0	16	H1	I/O	General-purpose digital I/O Conversion clock output ADC (not available on '6632, '6631, '6630 devices) DMA external trigger input	
P2.0/P2MAP0	17	G4	I/O	General-purpose digital I/O with port interrupt and map-able secondary function Default mapping: USCI_B0 SPI slave transmit enable; USCI_A0 clock input/output	
P2.1/P2MAP1	18	H2	I/O	General-purpose digital I/O with port interrupt and map-able secondary function Default mapping: USCI_B0 SPI slave in/master out; USCI_B0 I2C data	
P2.2/P2MAP2	19	J1	I/O	General-purpose digital I/O with port interrupt and map-able secondary function Default mapping: USCI_B0 SPI slave out/master in; USCI_B0 I2C clock	
P2.3/P2MAP3	20	H4	I/O	General-purpose digital I/O with port interrupt and map-able secondary function Default mapping: USCI_B0 clock input/output; USCI_A0 SPI slave transmit enable	
P2.4/P2MAP4	21	J2	I/O	General-purpose digital I/O with port interrupt and map-able secondary function Default mapping: USCI_A0 UART transmit data; USCI_A0 SPI slave in/master out	
P2.5/P2MAP5	22	K1	I/O	General-purpose digital I/O with port interrupt and map-able secondary function Default mapping: USCI_A0 UART receive data; USCI_A0 slave out/master in	

(1) I = input, O = output, N/A = not available on this package offering

Table 3. Terminal Functions (continued)

TERMINAL		I/O ⁽¹⁾	DESCRIPTION	
NAME	NO.			
	PZ			ZQW
P2.6/P2MAP6/R03	23	K2	I/O	General-purpose digital I/O with port interrupt and map-able secondary function Default mapping: no secondary function Input/output port of lowest analog LCD voltage (V5)
P2.7/P2MAP7/LCDREF/R13	24	L2	I/O	General-purpose digital I/O with port interrupt and map-able secondary function Default mapping: no secondary function External reference voltage input for regulated LCD voltage Input/output port of third most positive analog LCD voltage (V3 or V4)
DVCC1	25	L1		Digital power supply
DVSS1	26	M1		Digital ground supply
VCORE ⁽²⁾	27	M2		Regulated core power supply (internal usage only, no external current loading)
P5.2/R23	28	L3	I/O	General-purpose digital I/O Input/output port of second most positive analog LCD voltage (V2)
LDCAP/R33	29	M3	I/O	LCD capacitor connection Input/output port of most positive analog LCD voltage (V1) CAUTION: LDCAP/R33 must be connected to DV _{SS} if not used.
COM0	30	J4	O	LCD common output COM0 for LCD backplane
P5.3/COM1/S42	31	L4	I/O	General-purpose digital I/O LCD common output COM1 for LCD backplane LCD segment output S42
P5.4/COM2/S41	32	M4	I/O	General-purpose digital I/O LCD common output COM2 for LCD backplane LCD segment output S41
P5.5/COM3/S40	33	J5	I/O	General-purpose digital I/O LCD common output COM3 for LCD backplane LCD segment output S40
P1.0/TA0CLK/ACLK/S39	34	L5	I/O	General-purpose digital I/O with port interrupt Timer TA0 clock signal TACLK input ACLK output (divided by 1, 2, 4, or 8) LCD segment output S39
P1.1/TA0.0/S38	35	M5	I/O	General-purpose digital I/O with port interrupt Timer TA0 CCR0 capture: CCI0A input, compare: Out0 output BSL transmit output LCD segment output S38
P1.2/TA0.1/S37	36	J6	I/O	General-purpose digital I/O with port interrupt Timer TA0 CCR1 capture: CCI1A input, compare: Out1 output BSL receive input LCD segment output S37
P1.3/TA0.2/S36	37	H6	I/O	General-purpose digital I/O with port interrupt Timer TA0 CCR2 capture: CCI2A input, compare: Out2 output LCD segment output S36
P1.4/TA0.3/S35	38	M6	I/O	General-purpose digital I/O with port interrupt Timer TA0 CCR3 capture: CCI3A input compare: Out3 output LCD segment output S35
P1.5/TA0.4/S34	39	L6	I/O	General-purpose digital I/O with port interrupt Timer TA0 CCR4 capture: CCI4A input, compare: Out4 output LCD segment output S34
P1.6/TA0.1/S33	40	J7	I/O	General-purpose digital I/O with port interrupt Timer TA0 CCR1 capture: CCI1B input, compare: Out1 output LCD segment output S33
P1.7/TA0.2/S32	41	M7	I/O	General-purpose digital I/O with port interrupt Timer TA0 CCR2 capture: CCI2B input, compare: Out2 output LCD segment output S32

(2) V_{CORE} is for internal usage only. No external current loading is possible. V_{CORE} should only be connected to the recommended capacitor value, C_{VCORE}.

Table 3. Terminal Functions (continued)

TERMINAL			I/O ⁽¹⁾	DESCRIPTION
NAME	NO.			
	PZ	ZQW		
P3.0/TA1CLK/CBOUT/S31	42	L7	I/O	General-purpose digital I/O with port interrupt Timer TA1 clock input Comparator_B output LCD segment output S31
P3.1/TA1.0/S30	43	H7	I/O	General-purpose digital I/O with port interrupt Timer TA1 capture CCR0: CCI0A/CCI0B input, compare: Out0 output LCD segment output S30
P3.2/TA1.1/S29	44	M8	I/O	General-purpose digital I/O with port interrupt Timer TA1 capture CCR1: CCI1A/CCI1B input, compare: Out1 output LCD segment output S29
P3.3/TA1.2/S28	45	L8	I/O	General-purpose digital I/O with port interrupt Timer TA1 capture CCR2: CCI2A/CCI2B input, compare: Out2 output LCD segment output S28
P3.4/TA2CLK/SMCLK/S27	46	J8	I/O	General-purpose digital I/O with port interrupt Timer TA2 clock input SMCLK output LCD segment output S27
P3.5/TA2.0/S26	47	M9	I/O	General-purpose digital I/O with port interrupt Timer TA2 capture CCR0: CCI0A/CCI0B input, compare: Out0 output LCD segment output S26
P3.6/TA2.1/S25	48	L9	I/O	General-purpose digital I/O with port interrupt Timer TA2 capture CCR1: CCI1A/CCI1B input, compare: Out1 output LCD segment output S25
P3.7/TA2.2/S24	49	M10	I/O	General-purpose digital I/O with port interrupt Timer TA2 capture CCR2: CCI2A/CCI2B input, compare: Out2 output LCD segment output S24
P4.0/TB0.0/S23	50	J9	I/O	General-purpose digital I/O with port interrupt Timer TB0 capture CCR0: CCI0A/CCI0B input, compare: Out0 output LCD segment output S23
P4.1/TB0.1/S22	51	M11	I/O	General-purpose digital I/O with port interrupt Timer TB0 capture CCR1: CCI1A/CCI1B input, compare: Out1 output LCD segment output S22
P4.2/TB0.2/S21	52	L10	I/O	General-purpose digital I/O with port interrupt Timer TB0 capture CCR2: CCI2A/CCI2B input, compare: Out2 output LCD segment output S21
P4.3/TB0.3/S20	53	M12	I/O	General-purpose digital I/O with port interrupt Timer TB0 capture CCR3: CCI3A/CCI3B input, compare: Out3 output LCD segment output S20
P4.4/TB0.4/S19	54	L12	I/O	General-purpose digital I/O with port interrupt Timer TB0 capture CCR4: CCI4A/CCI4B input, compare: Out4 output LCD segment output S19
P4.5/TB0.5/S18	55	L11	I/O	General-purpose digital I/O with port interrupt Timer TB0 capture CCR5: CCI5A/CCI5B input, compare: Out5 output LCD segment output S18
P4.6/TB0.6/S17	56	K11	I/O	General-purpose digital I/O with port interrupt Timer TB0 capture CCR6: CCI6A/CCI6B input, compare: Out6 output LCD segment output S17
P4.7/TB0OUTH/SVMOUT/S16	57	K12	I/O	General-purpose digital I/O with port interrupt Timer TB0: Switch all PWM outputs high impedance SVM output LCD segment output S16
P8.0/TB0CLK/S15	58	J11	I/O	General-purpose digital I/O Timer TB0 clock input LCD segment output S15
P8.1/UCB1STE/UCA1CLK/S14	59	J12	I/O	General-purpose digital I/O USCI_B1 SPI slave transmit enable; USCI_A1 clock input/output LCD segment output S14

Table 3. Terminal Functions (continued)

TERMINAL			I/O ⁽¹⁾	DESCRIPTION
NAME	NO.			
	PZ	ZQW		
P8.2/UCA1TXD/UCA1SIMO/S13	60	H11	I/O	General-purpose digital I/O USCI_A1 UART transmit data; USCI_A1 SPI slave in/master out LCD segment output S13
P8.3/UCA1RXD/UCA1SOMI/S12	61	H12	I/O	General-purpose digital I/O USCI_A1 UART receive data; USCI_A1 SPI slave out/master in LCD segment output S12
P8.4/UCB1CLK/UCA1STE/S11	62	G11	I/O	General-purpose digital I/O USCI_B1 clock input/output; USCI_A1 SPI slave transmit enable LCD segment output S11
DVSS2	63	G12		Digital ground supply
DVCC2	64	F12		Digital power supply
P8.5/UCB1SIMO/UCB1SDA/S10	65	F11	I/O	General-purpose digital I/O USCI_B1 SPI slave in/master out; USCI_B1 I2C data LCD segment output S10
P8.6/UCB1SOMI/UCB1SCL/S9	66	G9	I/O	General-purpose digital I/O USCI_B1 SPI slave out/master in; USCI_B1 I2C clock LCD segment output S9
P8.7/S8	67	E12	I/O	General-purpose digital I/O LCD segment output S8
P9.0/S7	68	E11	I/O	General-purpose digital I/O LCD segment output S7
P9.1/S6	69	F9	I/O	General-purpose digital I/O LCD segment output S6
P9.2/S5	70	D12	I/O	General-purpose digital I/O LCD segment output S5
P9.3/S4	71	D11	I/O	General-purpose digital I/O LCD segment output S4
P9.4/S3	72	E9	I/O	General-purpose digital I/O LCD segment output S3
P9.5/S2	73	C12	I/O	General-purpose digital I/O LCD segment output S2
P9.6/S1	74	C11	I/O	General-purpose digital I/O LCD segment output S1
P9.7/S0	75	D9	I/O	General-purpose digital I/O LCD segment output S0
VSSU	76	B11 and B12		USB PHY ground supply
PU.0/DP	77	A12	I/O	General-purpose digital I/O - controlled by USB control register USB data terminal DP
PUR	78	B10	I/O	USB pull-up resistor pin (open drain)
PU.1/DM	79	A11	I/O	General-purpose digital I/O - controlled by USB control register USB data terminal DM
VBUS	80	A10		USB LDO input (connect to USB power source)
VUSB	81	A9		USB LDO output
V18	82	B9		USB regulated power (internal usage only, no external current loading)
AVSS3	83	A8		Analog ground supply
P7.2/XT2IN	84	B8	I/O	General-purpose digital I/O Input terminal for crystal oscillator XT2
P7.3/XT2OUT	85	B7	I/O	General-purpose digital I/O Output terminal of crystal oscillator XT2
VBAK	86	A7		Capacitor for backup subsystem. Do not load this pin externally. For capacitor values, see C _{BAK} in Recommended Operating Conditions .

Table 3. Terminal Functions (continued)

TERMINAL			I/O ⁽¹⁾	DESCRIPTION
NAME	NO.			
	PZ	ZQW		
VBAT	87	D8		Backup/secondary supply voltage. If backup voltage is not supplied connect to DVCC externally.
P5.7/RTCCLK	88	D7	I/O	General-purpose digital I/O RTCCLK output
DVCC3	89	A6		Digital power supply
DVSS3	90	A5		Digital ground supply
TEST/SBWTCK	91	B6	I	Test mode pin – select digital I/O on JTAG pins Spy-bi-wire input clock
PJ.0/TDO	92	B5	I/O	General-purpose digital I/O Test data output port
PJ.1/TDI/TCLK	93	A4	I/O	General-purpose digital I/O Test data input or test clock input
PJ.2/TMS	94	E7	I/O	General-purpose digital I/O Test mode select
PJ.3/TCK	95	D6	I/O	General-purpose digital I/O Test clock
$\overline{\text{RST}}/\text{NMI}/\text{SBWTDIO}$	96	A3	I/O	Reset input active low Non-maskable interrupt input Spy-bi-wire data input/output
P6.0/CB0/A0	97	B4	I/O	General-purpose digital I/O Comparator_B input CB0 Analog input A0 – ADC (not available on '6632, '6631, '6630 devices)
P6.1/CB1/A1	98	B3	I/O	General-purpose digital I/O Comparator_B input CB1 Analog input A1 – ADC (not available on '6632, '6631, '6630 devices)
P6.2/CB2/A2	99	A2	I/O	General-purpose digital I/O Comparator_B input CB2 Analog input A2 – ADC (not available on '6632, '6631, '6630 devices)
P6.3/CB3/A3	100	D5	I/O	General-purpose digital I/O Comparator_B input CB3 Analog input A3 – ADC (not available on '6632, '6631, '6630 devices)
Reserved	N/A	E5 E6 E8 F4 F5 F8 G5 G8 H5 H8 H9		Reserved BGA package balls. It is recommended to connect to ground (DV _{SS} /AV _{SS}).

SHORT-FORM DESCRIPTION

CPU

The MSP430 CPU has a 16-bit RISC architecture that is highly transparent to the application. All operations, other than program-flow instructions, are performed as register operations in conjunction with seven addressing modes for source operand and four addressing modes for destination operand.

The CPU is integrated with 16 registers that provide reduced instruction execution time. The register-to-register operation execution time is one cycle of the CPU clock.

Four of the registers, R0 to R3, are dedicated as program counter, stack pointer, status register, and constant generator, respectively. The remaining registers are general-purpose registers.

Peripherals are connected to the CPU using data, address, and control buses, and can be handled with all instructions.

Instruction Set

The instruction set consists of the original 51 instructions with three formats and seven address modes and additional instructions for the expanded address range. Each instruction can operate on word and byte data. [Table 4](#) shows examples of the three types of instruction formats; [Table 5](#) shows the address modes.

Program Counter	PC/R0
Stack Pointer	SP/R1
Status Register	SR/CG1/R2
Constant Generator	CG2/R3
General-Purpose Register	R4
General-Purpose Register	R5
General-Purpose Register	R6
General-Purpose Register	R7
General-Purpose Register	R8
General-Purpose Register	R9
General-Purpose Register	R10
General-Purpose Register	R11
General-Purpose Register	R12
General-Purpose Register	R13
General-Purpose Register	R14
General-Purpose Register	R15

Table 4. Instruction Word Formats

INSTRUCTION WORD FORMAT	EXAMPLE	OPERATION
Dual operands, source-destination	ADD R4,R5	R4 + R5 → R5
Single operands, destination only	CALL R8	PC → (TOS), R8 → PC
Relative jump, un/conditional	JNE	Jump-on-equal bit = 0

Table 5. Address Mode Descriptions

ADDRESS MODE	S ⁽¹⁾	D ⁽¹⁾	SYNTAX	EXAMPLE	OPERATION
Register	+	+	MOV Rs,Rd	MOV R10,R11	R10 → R11
Indexed	+	+	MOV X(Rn),Y(Rm)	MOV 2(R5),6(R6)	M(2+R5) → M(6+R6)
Symbolic (PC relative)	+	+	MOV EDE,TONI		M(EDE) → M(TONI)
Absolute	+	+	MOV &MEM, &TCDAT		M(MEM) → M(TCDAT)
Indirect	+		MOV @Rn,Y(Rm)	MOV @R10,Tab(R6)	M(R10) → M(Tab+R6)
Indirect auto-increment	+		MOV @Rn+,Rm	MOV @R10+,R11	M(R10) → R11 R10 + 2 → R10
Immediate	+		MOV #X,TONI	MOV #45,TONI	#45 → M(TONI)

(1) S = source, D = destination

Operating Modes

The MSP430 has one active mode and seven software selectable low-power modes of operation. An interrupt event can wake up the device from any of the low-power modes, service the request, and restore back to the low-power mode on return from the interrupt program.

The following seven operating modes can be configured by software:

- Active mode (AM)
 - All clocks are active
- Low-power mode 0 (LPM0)
 - CPU is disabled
 - ACLK and SMCLK remain active, MCLK is disabled
 - FLL loop control remains active
- Low-power mode 1 (LPM1)
 - CPU is disabled
 - FLL loop control is disabled
 - ACLK and SMCLK remain active, MCLK is disabled
- Low-power mode 2 (LPM2)
 - CPU is disabled
 - MCLK, FLL loop control, and DCOCLK are disabled
 - DCO's dc generator remains enabled
 - ACLK remains active
- Low-power mode 3 (LPM3)
 - CPU is disabled
 - MCLK, FLL loop control, and DCOCLK are disabled
 - DCO's dc generator is disabled
 - ACLK remains active
- Low-power mode 4 (LPM4)
 - CPU is disabled
 - ACLK is disabled
 - MCLK, FLL loop control, and DCOCLK are disabled
 - DCO's dc generator is disabled
 - Crystal oscillator is stopped
 - Complete data retention
- Low-power mode 3.5 (LPM3.5)
 - Internal regulator disabled
 - No data retention
 - RTC enabled and clocked by low-frequency oscillator
 - Wakeup from $\overline{\text{RST}}/\text{NMI}$, RTC_B, P1, P2, P3, and P4
- Low-power mode 4.5 (LPM4.5)
 - Internal regulator disabled
 - No data retention
 - Wakeup from $\overline{\text{RST}}/\text{NMI}$, RTC_B, P1, P2, P3, and P4

Interrupt Vector Addresses

The interrupt vectors and the power-up start address are located in the address range 0FFFFh to 0FF80h. The vector contains the 16-bit address of the appropriate interrupt-handler instruction sequence.

Table 6. Interrupt Sources, Flags, and Vectors of MSP430F663x Configurations

INTERRUPT SOURCE	INTERRUPT FLAG	SYSTEM INTERRUPT	WORD ADDRESS	PRIORITY
System Reset Power-Up, External Reset Watchdog Timeout, Key Violation Flash Memory Key Violation	WDTIFG, KEYV (SYSRSTIV) ^{(1) (2)}	Reset	0FFFEh	63, highest
System NMI PMM Vacant Memory Access JTAG Mailbox	SVMLIFG, SVMHIFG, DLYLIFG, DLYHIFG, VLRIFG, VLRHIFG, VMAIFG, JMBNIFG, JMBOUTIFG (SYSSNIV) ⁽¹⁾	(Non)maskable	0FFFCh	62
User NMI NMI Oscillator Fault Flash Memory Access Violation	NMIIFG, OFIFG, ACCVIFG, BUSIFG (SYSUNIV) ^{(1) (2)}	(Non)maskable	0FFFAh	61
Comp_B	Comparator B interrupt flags (CBIV) ^{(1) (3)}	Maskable	0FFF8h	60
Timer TB0	TB0CCR0 CCIFG0 ⁽³⁾	Maskable	0FFF6h	59
Timer TB0	TB0CCR1 CCIFG1 to TB0CCR6 CCIFG6, TB0IFG (TBIV) ^{(1) (3)}	Maskable	0FFF4h	58
Watchdog Interval Timer Mode	WDTIFG	Maskable	0FFF2h	57
USCI_A0 Receive/Transmit	UCA0RXIFG, UCA0TXIFG (UCA0IV) ^{(1) (3)}	Maskable	0FFF0h	56
USCI_B0 Receive/Transmit	UCB0RXIFG, UCB0TXIFG (UCB0IV) ^{(1) (3)}	Maskable	0FFEEh	55
ADC12_A ⁽⁴⁾	ADC12IFG0 to ADC12IFG15 (ADC12IV) ^{(1) (3)}	Maskable	0FFECCh	54
Timer TA0	TA0CCR0 CCIFG0 ⁽³⁾	Maskable	0FFEAh	53
Timer TA0	TA0CCR1 CCIFG1 to TA0CCR4 CCIFG4, TA0IFG (TA0IV) ^{(1) (3)}	Maskable	0FFE8h	52
USB_UBM	USB interrupts (USBIV) ⁽¹⁾⁽³⁾	Maskable	0FFE6h	51
DMA	DMA0IFG, DMA1IFG, DMA2IFG, DMA3IFG, DMA4IFG, DMA5IFG (DMAIV) ^{(1) (3)}	Maskable	0FFE4h	50
Timer TA1	TA1CCR0 CCIFG0 ⁽³⁾	Maskable	0FFE2h	49
Timer TA1	TA1CCR1 CCIFG1 to TA1CCR2 CCIFG2, TA1IFG (TA1IV) ^{(1) (3)}	Maskable	0FFE0h	48
I/O Port P1	P1IFG.0 to P1IFG.7 (P1IV) ^{(1) (3)}	Maskable	0FFDEh	47
USCI_A1 Receive/Transmit	UCA1RXIFG, UCA1TXIFG (UCA1IV) ^{(1) (3)}	Maskable	0FFDCh	46
USCI_B1 Receive/Transmit	UCB1RXIFG, UCB1TXIFG (UCB1IV) ^{(1) (3)}	Maskable	0FFDAh	45
I/O Port P2	P2IFG.0 to P2IFG.7 (P2IV) ^{(1) (3)}	Maskable	0FFD8h	44
LCD_B	LCD_B Interrupt Flags (LCDBIV) ⁽¹⁾	Maskable	0FFD6h	43
RTC_B	RTCRDYIFG, RTCTEVIFG, RTCAIFG, RT0PSIFG, RT1PSIFG, RTCOFIFG (RTCIV) ^{(1) (3)}	Maskable	0FFD4h	42
DAC12_A ⁽⁵⁾	DAC12_0IFG, DAC12_1IFG ^{(1) (3)}	Maskable	0FFD2h	41
Timer TA2	TA2CCR0 CCIFG2 ⁽³⁾	Maskable	0FFD0h	40
Timer TA2	TA2CCR1 CCIFG1 to TA2CCR2, TA2IFG (TA2IV) ^{(1) (3)}	Maskable	0FFCEh	39
I/O Port P3	P3IFG.0 to P3IFG.7 (P3IV) ^{(1) (3)}	Maskable	0FFCCh	38
I/O Port P4	P4IFG.0 to P4IFG.7 (P4IV) ^{(1) (3)}	Maskable	0FFCAh	37

(1) Multiple source flags

(2) A reset is generated if the CPU tries to fetch instructions from within peripheral space or vacant memory space.

(Non)maskable: the individual interrupt-enable bit can disable an interrupt event, but the general-interrupt enable cannot disable it.

(3) Interrupt flags are located in the module.

(4) Only on devices with peripheral module ADC12_A, otherwise reserved.

(5) Only on devices with peripheral module DAC12_A, otherwise reserved.

Table 6. Interrupt Sources, Flags, and Vectors of MSP430F663x Configurations (continued)

INTERRUPT SOURCE	INTERRUPT FLAG	SYSTEM INTERRUPT	WORD ADDRESS	PRIORITY
Reserved	Reserved ⁽⁶⁾		0FFC8h	36
			⋮	⋮
			0FF80h	0, lowest

(6) Reserved interrupt vectors at addresses are not used in this device and can be used for regular program code if necessary. To maintain compatibility with other devices, it is recommended to reserve these locations.

Memory Organization

Table 7. Memory Organization^{(1) (2)}

		MSP430F6636 MSP430F6633 MSP430F6630	MSP430F6637 MSP430F6634 MSP430F6631	MSP430F6638 MSP430F6635 MSP430F6632
Memory (flash) Main: interrupt vector	Total Size	128KB 00FFFFh–00FF80h	192KB 00FFFFh–00FF80h	256KB 00FFFFh–00FF80h
Main: code memory	Bank 3	N/A	N/A	64 KB 047FFF–038000h
	Bank 2	N/A	64 KB 037FFF–028000h	64 KB 037FFF–028000h
	Bank 1	64 KB 027FFF–018000h	64 KB 027FFF–018000h	64 KB 027FFF–018000h
	Bank 0	64 KB 017FFF–008000h	64 KB 017FFF–008000h	64 KB 017FFF–008000h
RAM	Sector 3	4 KB 0063FFh–005400h	4 KB 0063FFh–005400h	4 KB 0063FFh–005400h
	Sector 2	4 KB 0053FFh–004400h	4 KB 0053FFh–004400h	4 KB 0053FFh–004400h
	Sector 1	4 KB 0043FFh–003400h	4 KB 0043FFh–003400h	4 KB 0043FFh–003400h
	Sector 0	4 KB 0033FFh–002400h	4 KB 0033FFh–002400h	4 KB 0033FFh–002400h
USB RAM ⁽³⁾	Size RAM	2KB 0023FFh–001C00h	2KB 0023FFh–001C00h	2KB 0023FFh–001C00h
Information memory (flash)	Info A	128 B 0019FFh–001980h	128 B 0019FFh–001980h	128 B 0019FFh–001980h
	Info B	128 B 00197Fh–001900h	128 B 00197Fh–001900h	128 B 00197Fh–001900h
	Info C	128 B 0018FFh–001880h	128 B 0018FFh–001880h	128 B 0018FFh–001880h
	Info D	128 B 00187Fh–001800h	128 B 00187Fh–001800h	128 B 00187Fh–001800h
Bootstrap loader (BSL) memory (flash)	BSL 3	512 B 0017FFh–001600h	512 B 0017FFh–001600h	512 B 0017FFh–001600h
	BSL 2	512 B 0015FFh–001400h	512 B 0015FFh–001400h	512 B 0015FFh–001400h
	BSL 1	512 B 0013FFh–001200h	512 B 0013FFh–001200h	512 B 0013FFh–001200h
	BSL 0	512 B 0011FFh–001000h	512 B 0011FFh–001000h	512 B 0011FFh–001000h
Peripherals	Size	4KB 000FFFh–000000h	4KB 000FFFh–000000h	4KB 000FFFh–000000h

(1) N/A = Not available.

(2) Backup RAM is accessed via the control registers BAKMEM0, BAKMEM1, BAKMEM2, and BAKMEM3.

(3) USB RAM can be used as general purpose RAM when not used for USB operation.

Bootstrap Loader (BSL)

The BSL enables users to program the flash memory or RAM using various serial interfaces. Access to the device memory via the BSL is protected by an user-defined password. For complete description of the features of the BSL and its implementation, see the *MSP430 Memory Programming User's Guide (SLAU265)*.

USB BSL

All devices come pre-programmed with the USB BSL. Usage of the USB BSL requires external access to the six pins shown in [Table 8](#). In addition to these pins, the application must support external components necessary for normal USB operation; for example, proper crystal on XT2IN and XT2OUT, proper decoupling, etc.

Table 8. USB BSL Pin Requirements and Functions

DEVICE SIGNAL	BSL FUNCTION
$\overline{\text{RST}}/\text{NMI}/\text{SBWTDIO}$	Entry sequence signal
PU.0/DP	USB data terminal DP
PU.1/DM	USB data terminal DM
PUR	USB pullup resistor terminal
VBUS	USB bus power supply
VSSU	USB ground supply

UART BSL

A UART BSL is also available that can be programmed by the user into the BSL memory by replacing the pre-programmed, factory supplied, USB BSL. Usage of the UART BSL requires external access to the six pins shown in [Table 9](#).

Table 9. UART BSL Pin Requirements and Functions

DEVICE SIGNAL	BSL FUNCTION
$\overline{\text{RST}}/\text{NMI}/\text{SBWTDIO}$	Entry sequence signal
TEST/SBWTKK	Entry sequence signal
P1.1	Data transmit
P1.2	Data receive
VCC	Power supply
VSS	Ground supply

JTAG Operation

JTAG Standard Interface

The MSP430 family supports the standard JTAG interface which requires four signals for sending and receiving data. The JTAG signals are shared with general-purpose I/O. The TEST/SBWTCK pin is used to enable the JTAG signals. In addition to these signals, the $\overline{\text{RST}}/\text{NMI}/\text{SBWTDIO}$ is required to interface with MSP430 development tools and device programmers. The JTAG pin requirements are shown in [Table 10](#). For further details on interfacing to development tools and device programmers, see the *MSP430 Hardware Tools User's Guide* ([SLAU278](#)).

Table 10. JTAG Pin Requirements and Functions

DEVICE SIGNAL	DIRECTION	FUNCTION
PJ.3/TCK	IN	JTAG clock input
PJ.2/TMS	IN	JTAG state control
PJ.1/TDI/TCLK	IN	JTAG data input/TCLK input
PJ.0/TDO	OUT	JTAG data output
TEST/SBWTCK	IN	Enable JTAG pins
$\overline{\text{RST}}/\text{NMI}/\text{SBWTDIO}$	IN	External reset
VCC		Power supply
VSS		Ground supply

Spy-Bi-Wire Interface

In addition to the standard JTAG interface, the MSP430 family supports the two wire Spy-Bi-Wire interface. Spy-Bi-Wire can be used to interface with MSP430 development tools and device programmers. The Spy-Bi-Wire interface pin requirements are shown in [Table 11](#). For further details on interfacing to development tools and device programmers, see the *MSP430 Hardware Tools User's Guide* ([SLAU278](#)).

Table 11. Spy-Bi-Wire Pin Requirements and Functions

DEVICE SIGNAL	DIRECTION	FUNCTION
TEST/SBWTCK	IN	Spy-Bi-Wire clock input
$\overline{\text{RST}}/\text{NMI}/\text{SBWTDIO}$	IN, OUT	Spy-Bi-Wire data input/output
VCC		Power supply
VSS		Ground supply

Flash Memory

The flash memory can be programmed via the JTAG port, Spy-Bi-Wire (SBW), the BSL, or in-system by the CPU. The CPU can perform single-byte, single-word, and long-word writes to the flash memory. Features of the flash memory include:

- Flash memory has n segments of main memory and four segments of information memory (A to D) of 128 bytes each. Each segment in main memory is 512 bytes in size.
- Segments 0 to n may be erased in one step, or each segment may be individually erased.
- Segments A to D can be erased individually, or as a group with segments 0 to n. Segments A to D are also called *information memory*.
- Segment A can be locked separately.

RAM Memory

The RAM memory is made up of n sectors. Each sector can be completely powered down to save leakage, however all data is lost. Features of the RAM memory include:

- RAM memory has n sectors. The size of a sector can be found in [Memory Organization](#).
- Each sector 0 to n can be complete disabled, however data retention is lost.
- Each sector 0 to n automatically enters low power retention mode when possible.
- For devices that contain USB memory, the USB memory can be used as normal RAM if USB is not required.

Backup RAM Memory

The backup RAM provides a limited number of bytes of RAM that are retained during LPMx.5 and during operation from a backup supply if the Battery Backup System module is implemented.

There are 8 bytes of Backup RAM available on MSP430F663x. It can be wordwise accessed via the control registers BAKMEM0, BAKMEM1, BAKMEM2, and BAKMEM3.

Peripherals

Peripherals are connected to the CPU through data, address, and control buses and can be handled using all instructions. For complete module descriptions, see the *MSP430x5xx/MSP430x6xx Family User's Guide (SLAU208)*.

Digital I/O

There are up to nine 8-bit I/O ports implemented: P1 through P9 are complete, and port PJ contains four individual I/O ports.

- All individual I/O bits are independently programmable.
- Any combination of input, output, and interrupt conditions is possible.
- Programmable pullup or pulldown on all ports.
- Programmable drive strength on all ports.
- Edge-selectable interrupt input capability for all the eight bits of ports P1, P2, P3, and P4.
- Read/write access to port-control registers is supported by all instructions.
- Ports can be accessed byte-wise (P1 through P9) or word-wise in pairs (PA through PD).

Port Mapping Controller

The port mapping controller allows the flexible and reconfigurable mapping of digital functions to port P2.

Table 12. Port Mapping, Mnemonics and Functions

VALUE	PxMAPy MNEMONIC	INPUT PIN FUNCTION	OUTPUT PIN FUNCTION
0	PM_NONE	None	DV _{SS}
1	PM_CBOU	-	Comparator_B output
	PM_TB0CLK	Timer TB0 clock input	-
2	PM_ADC12CLK	-	ADC12CLK
	PM_DMAE0	DMAE0 Input	-
3	PM_SVMOUT	-	SVM output
	PM_TB0OUTH	Timer TB0 high impedance input TB0OUTH	-
4	PM_TB0CCR0B	Timer TB0 CCR0 capture input CCI0B	Timer TB0: TB0.0 compare output Out0
5	PM_TB0CCR1B	Timer TB0 CCR1 capture input CCI1B	Timer TB0: TB0.1 compare output Out1
6	PM_TB0CCR2B	Timer TB0 CCR2 capture input CCI2B	Timer TB0: TB0.2 compare output Out2
7	PM_TB0CCR3B	Timer TB0 CCR3 capture input CCI3B	Timer TB0: TB0.3 compare output Out3
8	PM_TB0CCR4B	Timer TB0 CCR4 capture input CCI4B	Timer TB0: TB0.4 compare output Out4
9	PM_TB0CCR5B	Timer TB0 CCR5 capture input CCI5B	Timer TB0: TB0.5 compare output Out5
10	PM_TB0CCR6B	Timer TB0 CCR6 capture input CCI6B	Timer TB0: TB0.6 compare output Out6
11	PM_UCA0RXD	USCI_A0 UART RXD (Direction controlled by USCI - input)	
	PM_UCA0SOMI	USCI_A0 SPI slave out master in (direction controlled by USCI)	
12	PM_UCA0TXD	USCI_A0 UART TXD (Direction controlled by USCI - output)	
	PM_UCA0SIMO	USCI_A0 SPI slave in master out (direction controlled by USCI)	
13	PM_UCA0CLK	USCI_A0 clock input/output (direction controlled by USCI)	
	PM_UCB0STE	USCI_B0 SPI slave transmit enable (direction controlled by USCI - input)	
14	PM_UCB0SOMI	USCI_B0 SPI slave out master in (direction controlled by USCI)	
	PM_UCB0SCL	USCI_B0 I2C clock (open drain and direction controlled by USCI)	

Table 12. Port Mapping, Mnemonics and Functions (continued)

VALUE	PxMAPy MNEMONIC	INPUT PIN FUNCTION	OUTPUT PIN FUNCTION
15	PM_UCB0SIMO	USCI_B0 SPI slave in master out (direction controlled by USCI)	
	PM_UCB0SDA	USCI_B0 I2C data (open drain and direction controlled by USCI)	
16	PM_UCB0CLK	USCI_B0 clock input/output (direction controlled by USCI)	
	PM_UCA0STE	USCI_A0 SPI slave transmit enable (direction controlled by USCI - input)	
17	PM_MCLK	-	MCLK
18	Reserved	Reserved for test purposes. Do not use this setting.	
19	Reserved	Reserved for test purposes. Do not use this setting.	
20 - 30	Reserved	None	DV _{SS}
31 (0FFh) ⁽¹⁾	PM_ANALOG	Disables the output driver as well as the input Schmitt-trigger to prevent parasitic cross currents when applying analog signals.	

(1) The value of the PMPAP_ANALOG mnemonic is set to 0FFh. The port mapping registers are only 5 bits wide and the upper bits are ignored resulting in a read out value of 31.

Table 13. Default Mapping

PIN	PxMAPy MNEMONIC	INPUT PIN FUNCTION	OUTPUT PIN FUNCTION
P2.0/P2MAP0	PM_UCB0STE/ PM_UCA0CLK	USCI_B0 SPI slave transmit enable (direction controlled by USCI - input) / USCI_A0 clock input/output (direction controlled by USCI)	
P2.1/P2MAP1	PM_UCB0SIMO/ PM_UCB0SDA	USCI_B0 SPI slave in master out (direction controlled by USCI) / USCI_B0 I2C data (open drain and direction controlled by USCI)	
P2.2/P2MAP2	PM_UCB0SOMI/ PM_UCB0SCL	USCI_B0 SPI slave out master in (direction controlled by USCI) / USCI_B0 I2C clock (open drain and direction controlled by USCI)	
P2.3/P2MAP3	PM_UCB0CLK/ PM_UCA0STE	USCI_B0 clock input/output (direction controlled by USCI) / USCI_A0 SPI slave transmit enable (direction controlled by USCI - input)	
P2.4/P2MAP4	PM_UCA0TXD/ PM_UCA0SIMO	USCI_A0 UART TXD (direction controlled by USCI - output) / USCI_A0 SPI slave in master out (direction controlled by USCI)	
P2.5/P2MAP5	PM_UCA0RXD/ PM_UCA0SOMI	USCI_A0 UART RXD (direction controlled by USCI - input) / USCI_A0 SPI slave out master in (direction controlled by USCI)	
P2.6/P2MAP6/R03	PM_NONE	-	DV _{SS}
P2.7/P2MAP7/LCDREF/R1 3	PM_NONE	-	DV _{SS}

Oscillator and System Clock

The clock system in the MSP430F663x family of devices is supported by the Unified Clock System (UCS) module that includes support for a 32-kHz watch crystal oscillator (in XT1 LF mode; XT1 HF mode is not supported), an internal very-low-power low-frequency oscillator (VLO), an internal trimmed low-frequency oscillator (REFO), an integrated internal digitally-controlled oscillator (DCO), and a high-frequency crystal oscillator XT2. The UCS module is designed to meet the requirements of both low system cost and low power consumption. The UCS module features digital frequency locked loop (FLL) hardware that, in conjunction with a digital modulator, stabilizes the DCO frequency to a programmable multiple of the watch crystal frequency. The internal DCO provides a fast turn-on clock source and stabilizes in 3 μ s (typical). The UCS module provides the following clock signals:

- Auxiliary clock (ACLK), sourced from a 32-kHz watch crystal (XT1), a high-frequency crystal (XT2), the internal low-frequency oscillator (VLO), the trimmed low-frequency oscillator (REFO), or the internal digitally-controlled oscillator DCO.
- Main clock (MCLK), the system clock used by the CPU. MCLK can be sourced by same sources available to ACLK.
- Sub-Main clock (SMCLK), the subsystem clock used by the peripheral modules. SMCLK can be sourced by same sources available to ACLK.
- ACLK/n, the buffered output of ACLK, ACLK/2, ACLK/4, ACLK/8, ACLK/16, ACLK/32.

Power Management Module (PMM)

The PMM includes an integrated voltage regulator that supplies the core voltage to the device and contains

programmable output levels to provide for power optimization. The PMM also includes supply voltage supervisor (SVS) and supply voltage monitoring (SVM) circuitry, as well as brownout protection. The brownout circuit is implemented to provide the proper internal reset signal to the device during power-on and power-off. The SVS/SVM circuitry detects if the supply voltage drops below a user-selectable level and supports both supply voltage supervision (the device is automatically reset) and supply voltage monitoring (the device is not automatically reset). SVS and SVM circuitry is available on the primary supply and core supply.

Hardware Multiplier

The multiplication operation is supported by a dedicated peripheral module. The module performs operations with 32-bit, 24-bit, 16-bit, and 8-bit operands. The module is capable of supporting signed and unsigned multiplication as well as signed and unsigned multiply and accumulate operations.

Real-Time Clock (RTC_B)

The RTC_B module can be configured for real-time clock (RTC) and calendar mode providing seconds, minutes, hours, day of week, day of month, month, and year. Calendar mode integrates an internal calendar which compensates for months with less than 31 days and includes leap year correction. The RTC_B also supports flexible alarm functions and offset-calibration hardware. The implementation on this device supports operation in LPM3.5 mode and operation from a backup supply.

Watchdog Timer (WDT_A)

The primary function of the watchdog timer (WDT_A) module is to perform a controlled system restart after a software problem occurs. If the selected time interval expires, a system reset is generated. If the watchdog function is not needed in an application, the module can be configured as an interval timer and can generate interrupts at selected time intervals.

System Module (SYS)

The SYS module handles many of the system functions within the device. These include power-on reset and power-up clear handling, NMI source selection and management, reset interrupt vector generators, bootstrap loader entry mechanisms, and configuration management (device descriptors). SYS also includes a data exchange mechanism via JTAG called a JTAG mailbox that can be used in the application.

Table 14. System Module Interrupt Vector Registers

INTERRUPT VECTOR REGISTER	INTERRUPT EVENT	WORD ADDRESS	OFFSET	PRIORITY
SYSRSTIV , System Reset	No interrupt pending	019Eh	00h	
	Brownout (BOR)		02h	Highest
	RST/NMI (BOR)		04h	
	DoBOR (BOR)		06h	
	LPM3.5 or LPM4.5 wakeup (BOR)		08h	
	Security violation (BOR)		0Ah	
	SVSL (POR)		0Ch	
	SVSH (POR)		0Eh	
	SVML_OVP (POR)		10h	
	SVMH_OVP (POR)		12h	
	DoPOR (POR)		14h	
	WDT timeout (PUC)		16h	
	WDT key violation (PUC)		18h	
	KEYV flash key violation (PUC)		1Ah	
	FLL unlock (PUC)		1Ch	
	Peripheral area fetch (PUC)		1Eh	
	PMM key violation (PUC)		20h	
	Reserved		22h to 3Eh	Lowest

Table 14. System Module Interrupt Vector Registers (continued)

INTERRUPT VECTOR REGISTER	INTERRUPT EVENT	WORD ADDRESS	OFFSET	PRIORITY
SYSSNIV , System NMI	No interrupt pending	019Ch	00h	
	SVMLIFG		02h	Highest
	SVMHIFG		04h	
	DLYLIFG		06h	
	DLYHIFG		08h	
	VMAIFG		0Ah	
	JMBINIFG		0Ch	
	JMBOUTIFG		0Eh	
	VLRLIFG		10h	
	VLRHIFG		12h	
	Reserved		14h to 1Eh	Lowest
SYSUNIV, User NMI	No interrupt pending	019Ah	00h	
	NMIFG		02h	Highest
	OFIFG		04h	
	ACCVIFG		06h	
	BUSIFG		08h	
	Reserved		0Ah to 1Eh	Lowest
SYSBERRIV, Bus Error	No interrupt pending	0198h	00h	
	USB wait state timeout		02h	Highest
	Reserved		04h to 1Eh	Lowest

DMA Controller

The DMA controller allows movement of data from one memory address to another without CPU intervention. For example, the DMA controller can be used to move data from the ADC12_A conversion memory to RAM. Using the DMA controller can increase the throughput of peripheral modules. The DMA controller reduces system power consumption by allowing the CPU to remain in sleep mode, without having to awaken to move data to or from a peripheral.

The USB timestamp generator also uses the channel 0, 1, and 2 DMA trigger assignments described in [Table 15](#).

Table 15. DMA Trigger Assignments⁽¹⁾

Trigger	Channel					
	0	1	2	3	4	5
0	DMAREQ					
1	TA0CCR0 CCIFG					
2	TA0CCR2 CCIFG					
3	TA1CCR0 CCIFG					
4	TA1CCR2 CCIFG					
5	TA2CCR0 CCIFG					
6	TA2CCR2 CCIFG					
7	TBCCR0 CCIFG					
8	TBCCR2 CCIFG					
9	Reserved					
10	Reserved					
11	Reserved					
12	Reserved					
13	Reserved					
14	Reserved					
15	Reserved					
16	UCA0RXIFG					
17	UCA0TXIFG					
18	UCB0RXIFG					
19	UCB0TXIFG					
20	UCA1RXIFG					
21	UCA1TXIFG					
22	UCB1RXIFG					
23	UCB1TXIFG					
24	ADC12IFGx ⁽²⁾					
25	DAC12_0IFG ⁽³⁾					
26	DAC12_1IFG ⁽³⁾					
27	USB FNRXD					
28	USB ready					
29	MPY ready					
30	DMA5IFG	DMA0IFG	DMA1IFG	DMA2IFG	DMA3IFG	DMA4IFG
31	DMAE0					

(1) Reserved DMA triggers may be used by other devices in the family. Reserved DMA triggers will not cause any DMA trigger event when selected.

(2) Only on devices with peripheral module ADC12_A. Reserved on devices without ADC.

(3) Only on devices with peripheral module DAC12_A. Reserved on devices without DAC.

Universal Serial Communication Interface (USCI)

The USCI modules are used for serial data communication. The USCI module supports synchronous communication protocols such as SPI (3 or 4 pin) and I²C, and asynchronous communication protocols such as UART, enhanced UART with automatic baudrate detection, and IrDA. Each USCI module contains two portions, A and B.

The USCI_An module provides support for SPI (3 or 4 pin), UART, enhanced UART, or IrDA.

The USCI_Bn module provides support for SPI (3 or 4 pin) or I2C.

The MSP430F663x series includes two complete USCI modules (n = 0 to 1).

Timer TA0

Timer TA0 is a 16-bit timer/counter (Timer_A type) with five capture/compare registers. It can support multiple capture/compares, PWM outputs, and interval timing. It also has extensive interrupt capabilities. Interrupts may be generated from the counter on overflow conditions and from each of the capture/compare registers.

Table 16. Timer TA0 Signal Connections

INPUT PIN NUMBER		DEVICE INPUT SIGNAL	MODULE INPUT SIGNAL	MODULE BLOCK	MODULE OUTPUT SIGNAL	DEVICE OUTPUT SIGNAL	OUTPUT PIN NUMBER	
PZ	ZQW						PZ	ZQW
34-P1.0	L5-P1.0	TA0CLK	TACLK	Timer	NA	NA		
		ACLK	ACLK					
		SMCLK	SMCLK					
34-P1.0	L5-P1.0	TA0CLK	$\overline{\text{TACLK}}$					
35-P1.1	M5-P1.1	TA0.0	CC10A	CCR0	TA0	TA0.0	35-P1.1	M5-P1.1
		DV _{SS}	CC10B					
		DV _{SS}	GND					
		DV _{CC}	V _{CC}					
36-P1.2	J6-P1.2	TA0.1	CC11A	CCR1	TA1	TA0.1	36-P1.2	J6-P1.2
40-P1.6	J7-P1.6	TA0.1	CC11B				40-P1.6	J7-P1.6
		DV _{SS}	GND				ADC12_A (internal) ⁽¹⁾ ADC12SHSx = {1}	
		DV _{CC}	V _{CC}					
37-P1.3	H6-P1.3	TA0.2	CC12A	CCR2	TA2	TA0.2	37-P1.3	H6-P1.3
41-P1.7	M7-P1.7	TA0.2	CC12B				41-P1.7	M7-P1.7
		DV _{SS}	GND					
		DV _{CC}	V _{CC}					
38-P1.4	M6-P1.4	TA0.3	CC13A	CCR3	TA3	TA0.3	38-P1.4	M6-P1.4
		DV _{SS}	CC13B					
		DV _{SS}	GND					
		DV _{CC}	V _{CC}					
39-P1.5	L6-P1.5	TA0.4	CC14A	CCR4	TA4	TA0.4	39-P1.5	L6-P1.5
		DV _{SS}	CC14B					
		DV _{SS}	GND					
		DV _{CC}	V _{CC}					

(1) Only on devices with peripheral module ADC12_A.

Timer TA1

Timer TA1 is a 16-bit timer/counter (Timer_A type) with three capture/compare registers. It supports multiple capture/comparers, PWM outputs, and interval timing. It also has extensive interrupt capabilities. Interrupts may be generated from the counter on overflow conditions and from each of the capture/compare registers.

Table 17. Timer TA1 Signal Connections

INPUT PIN NUMBER		DEVICE INPUT SIGNAL	MODULE INPUT SIGNAL	MODULE BLOCK	MODULE OUTPUT SIGNAL	DEVICE OUTPUT SIGNAL	OUTPUT PIN NUMBER	
PZ	ZQW						PZ	ZQW
42-P3.0	L7-P3.0	TA1CLK	TACLK	Timer	NA	NA		
		ACLK	ACLK					
		SMCLK	SMCLK					
42-P3.0	L7-P3.0	TA1CLK	$\overline{\text{TACLK}}$					
43-P3.1	H7-P3.1	TA1.0	CCI0A	CCR0	TA0	TA1.0	43-P3.1	H7-P3.1
		DV _{SS}	CCI0B					
		DV _{SS}	GND					
		DV _{CC}	V _{CC}					
44-P3.2	M8-P3.2	TA1.1	CCI1A	CCR1	TA1	TA1.1	44-P3.2	M8-P3.2
		CBOUT (internal)	CCI1B				DAC12_A (¹) DAC12_0, DAC12_1 (internal)	
		DV _{SS}	GND					
		DV _{CC}	V _{CC}					
45-P3.3	L8-P3.3	TA1.2	CCI2A	CCR2	TA2	TA1.2	45-P3.3	L8-P3.3
		ACLK (internal)	CCI2B					
		DV _{SS}	GND					
		DV _{CC}	V _{CC}					

(1) Only on devices with peripheral module DAC12_A.

Timer TA2

Timer TA2 is a 16-bit timer/counter (Timer_A type) with three capture/compare registers. It supports multiple capture/compares, PWM outputs, and interval timing. It also has extensive interrupt capabilities. Interrupts may be generated from the counter on overflow conditions and from each of the capture/compare registers.

Table 18. Timer TA2 Signal Connections

INPUT PIN NUMBER		DEVICE INPUT SIGNAL	MODULE INPUT SIGNAL	MODULE BLOCK	MODULE OUTPUT SIGNAL	DEVICE OUTPUT SIGNAL	OUTPUT PIN NUMBER	
PZ	ZQW						PZ	ZQW
46-P3.4	J8-P3.4	TA2CLK	TACLK	Timer	NA	NA		
		ACLK	ACLK					
		SMCLK	SMCLK					
46-P3.4	J8-P3.4	TA2CLK	$\overline{\text{TACLK}}$					
47-P3.5	M9-P3.5	TA2.0	CCI0A	CCR0	TA0	TA2.0	47-P3.5	M9-P3.5
		DV _{SS}	CCI0B					
		DV _{SS}	GND					
		DV _{CC}	V _{CC}					
48-P3.6	L9-P3.6	TA2.1	CCI1A	CCR1	TA1	TA2.1	48-P3.6	L9-P3.6
		CBOUT (internal)	CCI1B					
		DV _{SS}	GND					
		DV _{CC}	V _{CC}					
49-P3.7	M10-P3.7	TA2.2	CCI2A	CCR2	TA2	TA2.2	49-P3.7	M10-P3.7
		ACLK (internal)	CCI2B					
		DV _{SS}	GND					
		DV _{CC}	V _{CC}					

Timer TB0

Timer TB0 is a 16-bit timer/counter (Timer_B type) with seven capture/compare registers. It supports multiple capture/compares, PWM outputs, and interval timing. It also has extensive interrupt capabilities. Interrupts may be generated from the counter on overflow conditions and from each of the capture/compare registers.

Table 19. Timer TB0 Signal Connections

INPUT PIN NUMBER		DEVICE INPUT SIGNAL	MODULE INPUT SIGNAL	MODULE BLOCK	MODULE OUTPUT SIGNAL	DEVICE OUTPUT SIGNAL	OUTPUT PIN NUMBER			
PZ	ZQW						PZ	ZQW		
58-P8.0 P2MAPx ⁽¹⁾	J11-P8.0 P2MAPx ⁽¹⁾	TB0CLK	TB0CLK	Timer	NA	NA				
		ACLK	ACLK							
		SMCLK	SMCLK							
58-P8.0 P2MAPx ⁽¹⁾	J11-P8.0 P2MAPx ⁽¹⁾	TB0CLK	$\overline{\text{TB0CLK}}$							
50-P4.0 P2MAPx ⁽¹⁾	J9-P4.0 P2MAPx ⁽¹⁾	TB0.0	CC10A	CCR0	TB0	TB0.0	50-P4.0	J9-P4.0		
		TB0.0	CC10B							
		DV _{SS}	GND						ADC12 (internal) ⁽²⁾ ADC12SHSx = {2}	
		DV _{CC}	V _{CC}							
51-P4.1 P2MAPx ⁽¹⁾	M11-P4.1 P2MAPx ⁽¹⁾	TB0.1	CC11A	CCR1	TB1	TB0.1	51-P4.1	M11-P4.1		
		TB0.1	CC11B							
		DV _{SS}	GND						ADC12 (internal) ⁽²⁾ ADC12SHSx = {3}	
		DV _{CC}	V _{CC}							
52-P4.2 P2MAPx ⁽¹⁾	L10-P4.2 P2MAPx ⁽¹⁾	TB0.2	CC12A	CCR2	TB2	TB0.2	52-P4.2	L10-P4.2		
		TB0.2	CC12B							
		DV _{SS}	GND						DAC12_A ⁽³⁾ DAC12_0, DAC12_1 (internal)	
		DV _{CC}	V _{CC}							
53-P4.3 P2MAPx ⁽¹⁾	M12-P4.3 P2MAPx ⁽¹⁾	TB0.3	CC13A	CCR3	TB3	TB0.3	53-P4.3	M12-P4.3		
		TB0.3	CC13B							
		DV _{SS}	GND							
		DV _{CC}	V _{CC}							
54-P4.4 P2MAPx ⁽¹⁾	L12-P4.4 P2MAPx ⁽¹⁾	TB0.4	CC14A	CCR4	TB4	TB0.4	54-P4.4	L12-P4.4		
		TB0.4	CC14B							
		DV _{SS}	GND							
		DV _{CC}	V _{CC}							
55-P4.5 P2MAPx ⁽¹⁾	L11-P4.5 P2MAPx ⁽¹⁾	TB0.5	CC15A	CCR5	TB5	TB0.5	55-P4.5	L11-P4.5		
		TB0.5	CC15B							
		DV _{SS}	GND							
		DV _{CC}	V _{CC}							
56-P4.6 P2MAPx ⁽¹⁾	K11-P4.6 P2MAPx ⁽¹⁾	TB0.6	CC16A	CCR6	TB6	TB0.6	56-P4.6	K11-P4.6		
		TB0.6	CC16B							
		DV _{SS}	GND							
		DV _{CC}	V _{CC}							

(1) Timer functions selectable via the port mapping controller.

(2) Only on devices with peripheral module ADC12_A.

(3) Only on devices with peripheral module DAC12_A.

Comparator_B

The primary function of the Comparator_B module is to support precision slope analog-to-digital conversions, battery voltage supervision, and monitoring of external analog signals.

ADC12_A

The ADC12_A module supports fast 12-bit analog-to-digital conversions. The module implements a 12-bit SAR core, sample select control, reference generator, and a 16-word conversion-and-control buffer. The conversion-and-control buffer allows up to 16 independent ADC samples to be converted and stored without any CPU intervention.

DAC12_A

The DAC12_A module is a 12-bit R-ladder voltage-output DAC. The DAC12_A may be used in 8-bit or 12-bit mode, and may be used in conjunction with the DMA controller. When multiple DAC12_A modules are present, they may be grouped together for synchronous operation.

CRC16

The CRC16 module produces a signature based on a sequence of entered data values and can be used for data checking purposes. The CRC16 module signature is based on the CRC-CCITT standard.

REF Voltage Reference

The reference module (REF) is responsible for generation of all critical reference voltages that can be used by the various analog peripherals in the device.

LCD_B

The LCD_B driver generates the segment and common signals that are required to drive a liquid crystal display (LCD). The LCD_B controller has dedicated data memories to hold segment drive information. Common and segment signals are generated as defined by the mode. Static, 2-mux, 3-mux, and 4-mux LCDs are supported. The module can provide a LCD voltage independent of the supply voltage with its integrated charge pump. It is possible to control the level of the LCD voltage, and thus contrast, by software. The module also provides an automatic blinking capability for individual segments.

USB Universal Serial Bus

The USB module is a fully integrated USB interface that is compliant with the USB 2.0 specification. The module supports full-speed operation of control, interrupt, and bulk transfers. The module includes an integrated LDO, PHY, and PLL. The PLL is highly flexible and can support a wide range of input clock frequencies. USB RAM, when not used for USB communication, can be used by the system.

Embedded Emulation Module (EEM)

The Embedded Emulation Module (EEM) supports real-time in-system debugging. The L version of the EEM implemented on these devices has the following features:

- Eight hardware triggers/breakpoints on memory access
- Two hardware triggers/breakpoints on CPU register write access
- Up to ten hardware triggers can be combined to form complex triggers/breakpoints
- Two cycle counters
- Sequencer
- State storage
- Clock control on module level

Peripheral File Map
Table 20. Peripherals

MODULE NAME	BASE ADDRESS	OFFSET ADDRESS RANGE ⁽¹⁾
Special Functions (see Table 21)	0100h	000h - 01Fh
PMM (see Table 22)	0120h	000h - 00Fh
Flash Control (see Table 23)	0140h	000h - 00Fh
CRC16 (see Table 24)	0150h	000h - 007h
RAM Control (see Table 25)	0158h	000h - 001h
Watchdog (see Table 26)	015Ch	000h - 001h
UCS (see Table 27)	0160h	000h - 01Fh
SYS (see Table 28)	0180h	000h - 01Fh
Shared Reference (see Table 29)	01B0h	000h - 001h
Port Mapping Control (see Table 30)	01C0h	000h - 003h
Port Mapping Port P2 (see Table 30)	01D0h	000h - 007h
Port P1/P2 (see Table 31)	0200h	000h - 01Fh
Port P3/P4 (see Table 32)	0220h	000h - 01Fh
Port P5/P6 (see Table 33)	0240h	000h - 00Bh
Port P7/P8 (see Table 34)	0260h	000h - 00Bh
Port P9 (see Table 35)	0280h	000h - 00Bh
Port PJ (see Table 36)	0320h	000h - 01Fh
Timer TA0 (see Table 37)	0340h	000h - 02Eh
Timer TA1 (see Table 38)	0380h	000h - 02Eh
Timer TB0 (see Table 39)	03C0h	000h - 02Eh
Timer TA2 (see Table 40)	0400h	000h - 02Eh
Battery Backup (see Table 41)	0480h	000h - 01Fh
RTC_B (see Table 42)	04A0h	000h - 01Fh
32-bit Hardware Multiplier (see Table 43)	04C0h	000h - 02Fh
DMA General Control (see Table 44)	0500h	000h - 00Fh
DMA Channel 0 (see Table 44)	0510h	000h - 00Ah
DMA Channel 1 (see Table 44)	0520h	000h - 00Ah
DMA Channel 2 (see Table 44)	0530h	000h - 00Ah
DMA Channel 3 (see Table 44)	0540h	000h - 00Ah
DMA Channel 4 (see Table 44)	0550h	000h - 00Ah
DMA Channel 5 (see Table 44)	0560h	000h - 00Ah
USCI_A0 (see Table 45)	05C0h	000h - 01Fh
USCI_B0 (see Table 46)	05E0h	000h - 01Fh
USCI_A1 (see Table 47)	0600h	000h - 01Fh
USCI_B1 (see Table 48)	0620h	000h - 01Fh
ADC12_A (see Table 49)	0700h	000h - 03Fh
DAC12_A (see Table 50)	0780h	000h - 01Fh
Comparator_B (see Table 51)	08C0h	000h - 00Fh
USB configuration (see Table 52)	0900h	000h - 014h
USB control (see Table 53)	0920h	000h - 01Fh
LCD_B control (see Table 54)	0A00h	000h - 05Fh

(1) For a detailed description of the individual control register offset addresses, see the *MSP430F5xx and MSP430F6xx Family User's Guide (SLAU208)*.

Table 21. Special Function Registers (Base Address: 0100h)

REGISTER DESCRIPTION	REGISTER	OFFSET
SFR interrupt enable	SFRIE1	00h
SFR interrupt flag	SFRIFG1	02h
SFR reset pin control	SFRRPCR	04h

Table 22. PMM Registers (Base Address: 0120h)

REGISTER DESCRIPTION	REGISTER	OFFSET
PMM Control 0	PMMCTL0	00h
PMM control 1	PMMCTL1	02h
SVS high side control	SVSMHCTL	04h
SVS low side control	SVSMLCTL	06h
PMM interrupt flags	PMMIFG	0Ch
PMM interrupt enable	PMMIE	0Eh

Table 23. Flash Control Registers (Base Address: 0140h)

REGISTER DESCRIPTION	REGISTER	OFFSET
Flash control 1	FCTL1	00h
Flash control 3	FCTL3	04h
Flash control 4	FCTL4	06h

Table 24. CRC16 Registers (Base Address: 0150h)

REGISTER DESCRIPTION	REGISTER	OFFSET
CRC data input	CRC16DI	00h
CRC result	CRC16INIRES	04h

Table 25. RAM Control Registers (Base Address: 0158h)

REGISTER DESCRIPTION	REGISTER	OFFSET
RAM control 0	RCCTL0	00h

Table 26. Watchdog Registers (Base Address: 015Ch)

REGISTER DESCRIPTION	REGISTER	OFFSET
Watchdog timer control	WDTCTL	00h

Table 27. UCS Registers (Base Address: 0160h)

REGISTER DESCRIPTION	REGISTER	OFFSET
UCS control 0	UCSCTL0	00h
UCS control 1	UCSCTL1	02h
UCS control 2	UCSCTL2	04h
UCS control 3	UCSCTL3	06h
UCS control 4	UCSCTL4	08h
UCS control 5	UCSCTL5	0Ah
UCS control 6	UCSCTL6	0Ch
UCS control 7	UCSCTL7	0Eh
UCS control 8	UCSCTL8	10h

Table 28. SYS Registers (Base Address: 0180h)

REGISTER DESCRIPTION	REGISTER	OFFSET
System control	SYSCCTL	00h
Bootstrap loader configuration area	SYBSLCL	02h
JTAG mailbox control	SYSJMBC	06h
JTAG mailbox input 0	SYSJMBIO	08h
JTAG mailbox input 1	SYSJMBI1	0Ah
JTAG mailbox output 0	SYSJMBO0	0Ch
JTAG mailbox output 1	SYSJMBO1	0Eh
Bus Error vector generator	SYSBERRIV	18h
User NMI vector generator	SYSUNIV	1Ah
System NMI vector generator	SYSSNIV	1Ch
Reset vector generator	SYSRSTIV	1Eh

Table 29. Shared Reference Registers (Base Address: 01B0h)

REGISTER DESCRIPTION	REGISTER	OFFSET
Shared reference control	REFCTL	00h

**Table 30. Port Mapping Registers
(Base Address of Port Mapping Control: 01C0h, Port P2: 01D0h)**

REGISTER DESCRIPTION	REGISTER	OFFSET
Port mapping password register	PMAPPWD	00h
Port mapping control register	PMAPCTL	02h
Port P2.0 mapping register	P2MAP0	00h
Port P2.1 mapping register	P2MAP1	01h
Port P2.2 mapping register	P2MAP2	02h
Port P2.3 mapping register	P2MAP3	03h
Port P2.4 mapping register	P2MAP4	04h
Port P2.5 mapping register	P2MAP5	05h
Port P2.6 mapping register	P2MAP6	06h
Port P2.7 mapping register	P2MAP7	07h

Table 31. Port P1/P2 Registers (Base Address: 0200h)

REGISTER DESCRIPTION	REGISTER	OFFSET
Port P1 input	P1IN	00h
Port P1 output	P1OUT	02h
Port P1 direction	P1DIR	04h
Port P1 pullup/pulldown enable	P1REN	06h
Port P1 drive strength	P1DS	08h
Port P1 selection	P1SEL	0Ah
Port P1 interrupt vector word	P1IV	0Eh
Port P1 interrupt edge select	P1IES	18h
Port P1 interrupt enable	P1IE	1Ah
Port P1 interrupt flag	P1IFG	1Ch
Port P2 input	P2IN	01h
Port P2 output	P2OUT	03h
Port P2 direction	P2DIR	05h
Port P2 pullup/pulldown enable	P2REN	07h
Port P2 drive strength	P2DS	09h

Table 31. Port P1/P2 Registers (Base Address: 0200h) (continued)

REGISTER DESCRIPTION	REGISTER	OFFSET
Port P2 selection	P2SEL	0Bh
Port P2 interrupt vector word	P2IV	1Eh
Port P2 interrupt edge select	P2IES	19h
Port P2 interrupt enable	P2IE	1Bh
Port P2 interrupt flag	P2IFG	1Dh

Table 32. Port P3/P4 Registers (Base Address: 0220h)

REGISTER DESCRIPTION	REGISTER	OFFSET
Port P3 input	P3IN	00h
Port P3 output	P3OUT	02h
Port P3 direction	P3DIR	04h
Port P3 pullup/pulldown enable	P3REN	06h
Port P3 drive strength	P3DS	08h
Port P3 selection	P3SEL	0Ah
Port P3 interrupt vector word	P3IV	0Eh
Port P3 interrupt edge select	P3IES	18h
Port P3 interrupt enable	P3IE	1Ah
Port P3 interrupt flag	P3IFG	1Ch
Port P4 input	P4IN	01h
Port P4 output	P4OUT	03h
Port P4 direction	P4DIR	05h
Port P4 pullup/pulldown enable	P4REN	07h
Port P4 drive strength	P4DS	09h
Port P4 selection	P4SEL	0Bh
Port P4 interrupt vector word	P4IV	1Eh
Port P4 interrupt edge select	P4IES	19h
Port P4 interrupt enable	P4IE	1Bh
Port P4 interrupt flag	P4IFG	1Dh

Table 33. Port P5/P6 Registers (Base Address: 0240h)

REGISTER DESCRIPTION	REGISTER	OFFSET
Port P5 input	P5IN	00h
Port P5 output	P5OUT	02h
Port P5 direction	P5DIR	04h
Port P5 pullup/pulldown enable	P5REN	06h
Port P5 drive strength	P5DS	08h
Port P5 selection	P5SEL	0Ah
Port P6 input	P6IN	01h
Port P6 output	P6OUT	03h
Port P6 direction	P6DIR	05h
Port P6 pullup/pulldown enable	P6REN	07h
Port P6 drive strength	P6DS	09h
Port P6 selection	P6SEL	0Bh

Table 34. Port P7/P8 Registers (Base Address: 0260h)

REGISTER DESCRIPTION	REGISTER	OFFSET
Port P7 input	P7IN	00h
Port P7 output	P7OUT	02h
Port P7 direction	P7DIR	04h
Port P7 pullup/pulldown enable	P7REN	06h
Port P7 drive strength	P7DS	08h
Port P7 selection	P7SEL	0Ah
Port P8 input	P8IN	01h
Port P8 output	P8OUT	03h
Port P8 direction	P8DIR	05h
Port P8 pullup/pulldown enable	P8REN	07h
Port P8 drive strength	P8DS	09h
Port P8 selection	P8SEL	0Bh

Table 35. Port P9 Register (Base Address: 0280h)

REGISTER DESCRIPTION	REGISTER	OFFSET
Port P9 input	P9IN	00h
Port P9 output	P9OUT	02h
Port P9 direction	P9DIR	04h
Port P9 pullup/pulldown enable	P9REN	06h
Port P9 drive strength	P9DS	08h
Port P9 selection	P9SEL	0Ah

Table 36. Port J Registers (Base Address: 0320h)

REGISTER DESCRIPTION	REGISTER	OFFSET
Port PJ input	PJIN	00h
Port PJ output	PJOUT	02h
Port PJ direction	PJDIR	04h
Port PJ pullup/pulldown enable	PJREN	06h
Port PJ drive strength	PJDS	08h

Table 37. TA0 Registers (Base Address: 0340h)

REGISTER DESCRIPTION	REGISTER	OFFSET
TA0 control	TA0CTL	00h
Capture/compare control 0	TA0CCTL0	02h
Capture/compare control 1	TA0CCTL1	04h
Capture/compare control 2	TA0CCTL2	06h
Capture/compare control 3	TA0CCTL3	08h
Capture/compare control 4	TA0CCTL4	0Ah
TA0 counter register	TA0R	10h
Capture/compare register 0	TA0CCR0	12h
Capture/compare register 1	TA0CCR1	14h
Capture/compare register 2	TA0CCR2	16h
Capture/compare register 3	TA0CCR3	18h
Capture/compare register 4	TA0CCR4	1Ah
TA0 expansion register 0	TA0EX0	20h
TA0 interrupt vector	TA0IV	2Eh

Table 38. TA1 Registers (Base Address: 0380h)

REGISTER DESCRIPTION	REGISTER	OFFSET
TA1 control	TA1CTL	00h
Capture/compare control 0	TA1CCTL0	02h
Capture/compare control 1	TA1CCTL1	04h
Capture/compare control 2	TA1CCTL2	06h
TA1 counter register	TA1R	10h
Capture/compare register 0	TA1CCR0	12h
Capture/compare register 1	TA1CCR1	14h
Capture/compare register 2	TA1CCR2	16h
TA1 expansion register 0	TA1EX0	20h
TA1 interrupt vector	TA1IV	2Eh

Table 39. TB0 Registers (Base Address: 03C0h)

REGISTER DESCRIPTION	REGISTER	OFFSET
TB0 control	TB0CTL	00h
Capture/compare control 0	TB0CCTL0	02h
Capture/compare control 1	TB0CCTL1	04h
Capture/compare control 2	TB0CCTL2	06h
Capture/compare control 3	TB0CCTL3	08h
Capture/compare control 4	TB0CCTL4	0Ah
Capture/compare control 5	TB0CCTL5	0Ch
Capture/compare control 6	TB0CCTL6	0Eh
TB0 register	TB0R	10h
Capture/compare register 0	TB0CCR0	12h
Capture/compare register 1	TB0CCR1	14h
Capture/compare register 2	TB0CCR2	16h
Capture/compare register 3	TB0CCR3	18h
Capture/compare register 4	TB0CCR4	1Ah
Capture/compare register 5	TB0CCR5	1Ch
Capture/compare register 6	TB0CCR6	1Eh
TB0 expansion register 0	TB0EX0	20h
TB0 interrupt vector	TB0IV	2Eh

Table 40. TA2 Registers (Base Address: 0400h)

REGISTER DESCRIPTION	REGISTER	OFFSET
TA2 control	TA2CTL	00h
Capture/compare control 0	TA2CCTL0	02h
Capture/compare control 1	TA2CCTL1	04h
Capture/compare control 2	TA2CCTL2	06h
TA2 counter register	TA2R	10h
Capture/compare register 0	TA2CCR0	12h
Capture/compare register 1	TA2CCR1	14h
Capture/compare register 2	TA2CCR2	16h
TA2 expansion register 0	TA2EX0	20h
TA2 interrupt vector	TA2IV	2Eh

Table 41. Battery Backup Registers (Base Address: 0480h)

REGISTER DESCRIPTION	REGISTER	OFFSET
Battery Backup Memory 0	BAKMEM0	00h
Battery Backup Memory 1	BAKMEM1	02h
Battery Backup Memory 2	BAKMEM2	04h
Battery Backup Memory 3	BAKMEM3	06h
Battery Backup Control	BAKCTL	1Ch
Battery Charger Control	BAKCHCTL	1Eh

Table 42. Real-Time Clock Registers (Base Address: 04A0h)

REGISTER DESCRIPTION	REGISTER	OFFSET
RTC control register 0	RTCCTL0	00h
RTC control register 1	RTCCTL1	01h
RTC control register 2	RTCCTL2	02h
RTC control register 3	RTCCTL3	03h
RTC prescaler 0 control register	RTCPS0CTL	08h
RTC prescaler 1 control register	RTCPS1CTL	0Ah
RTC prescaler 0	RTCPS0	0Ch
RTC prescaler 1	RTCPS1	0Dh
RTC interrupt vector word	RTCIV	0Eh
RTC seconds	RTCSEC	10h
RTC minutes	RTCMIN	11h
RTC hours	RTCHOUR	12h
RTC day of week	RTCDOW	13h
RTC days	RTCDAY	14h
RTC month	RTCMON	15h
RTC year low	RTCYEARL	16h
RTC year high	RTCYEARH	17h
RTC alarm minutes	RTCAMIN	18h
RTC alarm hours	RTCAHOUR	19h
RTC alarm day of week	RTCADOW	1Ah
RTC alarm days	RTCADAY	1Bh
Binary-to-BCD conversion register	BIN2BCD	1Ch
BCD-to-binary conversion register	BCD2BIN	1Eh

Table 43. 32-bit Hardware Multiplier Registers (Base Address: 04C0h)

REGISTER DESCRIPTION	REGISTER	OFFSET
16-bit operand 1 – multiply	MPY	00h
16-bit operand 1 – signed multiply	MPYS	02h
16-bit operand 1 – multiply accumulate	MAC	04h
16-bit operand 1 – signed multiply accumulate	MACS	06h
16-bit operand 2	OP2	08h
16 × 16 result low word	RESLO	0Ah
16 × 16 result high word	RESHI	0Ch
16 × 16 sum extension register	SUMEXT	0Eh
32-bit operand 1 – multiply low word	MPY32L	10h
32-bit operand 1 – multiply high word	MPY32H	12h
32-bit operand 1 – signed multiply low word	MPYS32L	14h
32-bit operand 1 – signed multiply high word	MPYS32H	16h

Table 43. 32-bit Hardware Multiplier Registers (Base Address: 04C0h) (continued)

REGISTER DESCRIPTION	REGISTER	OFFSET
32-bit operand 1 – multiply accumulate low word	MAC32L	18h
32-bit operand 1 – multiply accumulate high word	MAC32H	1Ah
32-bit operand 1 – signed multiply accumulate low word	MACS32L	1Ch
32-bit operand 1 – signed multiply accumulate high word	MACS32H	1Eh
32-bit operand 2 – low word	OP2L	20h
32-bit operand 2 – high word	OP2H	22h
32 × 32 result 0 – least significant word	RES0	24h
32 × 32 result 1	RES1	26h
32 × 32 result 2	RES2	28h
32 × 32 result 3 – most significant word	RES3	2Ah
MPY32 control register 0	MPY32CTL0	2Ch

**Table 44. DMA Registers (Base Address DMA General Control: 0500h,
DMA Channel 0: 0510h, DMA Channel 1: 0520h, DMA Channel 2: 0530h, DMA Channel 3: 0540h, DMA
Channel 4: 0550h, DMA Channel 5: 0560h)**

REGISTER DESCRIPTION	REGISTER	OFFSET
DMA General Control: DMA module control 0	DMACTL0	00h
DMA General Control: DMA module control 1	DMACTL1	02h
DMA General Control: DMA module control 2	DMACTL2	04h
DMA General Control: DMA module control 3	DMACTL3	06h
DMA General Control: DMA module control 4	DMACTL4	08h
DMA General Control: DMA interrupt vector	DMAIV	0Ah
DMA Channel 0 control	DMA0CTL	00h
DMA Channel 0 source address low	DMA0SAL	02h
DMA Channel 0 source address high	DMA0SAH	04h
DMA Channel 0 destination address low	DMA0DAL	06h
DMA Channel 0 destination address high	DMA0DAH	08h
DMA Channel 0 transfer size	DMA0SZ	0Ah
DMA Channel 1 control	DMA1CTL	00h
DMA Channel 1 source address low	DMA1SAL	02h
DMA Channel 1 source address high	DMA1SAH	04h
DMA Channel 1 destination address low	DMA1DAL	06h
DMA Channel 1 destination address high	DMA1DAH	08h
DMA Channel 1 transfer size	DMA1SZ	0Ah
DMA Channel 2 control	DMA2CTL	00h
DMA Channel 2 source address low	DMA2SAL	02h
DMA Channel 2 source address high	DMA2SAH	04h
DMA Channel 2 destination address low	DMA2DAL	06h
DMA Channel 2 destination address high	DMA2DAH	08h
DMA Channel 2 transfer size	DMA2SZ	0Ah
DMA Channel 3 control	DMA3CTL	00h
DMA Channel 3 source address low	DMA3SAL	02h
DMA Channel 3 source address high	DMA3SAH	04h
DMA Channel 3 destination address low	DMA3DAL	06h
DMA Channel 3 destination address high	DMA3DAH	08h
DMA Channel 3 transfer size	DMA3SZ	0Ah
DMA Channel 4 control	DMA4CTL	00h
DMA Channel 4 source address low	DMA4SAL	02h

Table 44. DMA Registers (Base Address DMA General Control: 0500h, DMA Channel 0: 0510h, DMA Channel 1: 0520h, DMA Channel 2: 0530h, DMA Channel 3: 0540h, DMA Channel 4: 0550h, DMA Channel 5: 0560h) (continued)

REGISTER DESCRIPTION	REGISTER	OFFSET
DMA Channel 4 source address high	DMA4SAH	04h
DMA Channel 4 destination address low	DMA4DAL	06h
DMA Channel 4 destination address high	DMA4DAH	08h
DMA Channel 4 transfer size	DMA4SZ	0Ah
DMA Channel 5 control	DMA5CTL	00h
DMA Channel 5 source address low	DMA5SAL	02h
DMA Channel 5 source address high	DMA5SAH	04h
DMA Channel 5 destination address low	DMA5DAL	06h
DMA Channel 5 destination address high	DMA5DAH	08h
DMA Channel 5 transfer size	DMA5SZ	0Ah

Table 45. USCI_A0 Registers (Base Address: 05C0h)

REGISTER DESCRIPTION	REGISTER	OFFSET
USCI control 0	UCA0CTL0	00h
USCI control 1	UCA0CTL1	01h
USCI baud rate 0	UCA0BR0	06h
USCI baud rate 1	UCA0BR1	07h
USCI modulation control	UCA0MCTL	08h
USCI status	UCA0STAT	0Ah
USCI receive buffer	UCA0RXBUF	0Ch
USCI transmit buffer	UCA0TXBUF	0Eh
USCI LIN control	UCA0ABCTL	10h
USCI IrDA transmit control	UCA0IRTCTL	12h
USCI IrDA receive control	UCA0IRRCTL	13h
USCI interrupt enable	UCA0IE	1Ch
USCI interrupt flags	UCA0IFG	1Dh
USCI interrupt vector word	UCA0IV	1Eh

Table 46. USCI_B0 Registers (Base Address: 05E0h)

REGISTER DESCRIPTION	REGISTER	OFFSET
USCI synchronous control 0	UCB0CTL0	00h
USCI synchronous control 1	UCB0CTL1	01h
USCI synchronous bit rate 0	UCB0BR0	06h
USCI synchronous bit rate 1	UCB0BR1	07h
USCI synchronous status	UCB0STAT	0Ah
USCI synchronous receive buffer	UCB0RXBUF	0Ch
USCI synchronous transmit buffer	UCB0TXBUF	0Eh
USCI I2C own address	UCB0I2COA	10h
USCI I2C slave address	UCB0I2CSA	12h
USCI interrupt enable	UCB0IE	1Ch
USCI interrupt flags	UCB0IFG	1Dh
USCI interrupt vector word	UCB0IV	1Eh

Table 47. USCI_A1 Registers (Base Address: 0600h)

REGISTER DESCRIPTION	REGISTER	OFFSET
USCI control 0	UCA1CTL0	00h
USCI control 1	UCA1CTL1	01h
USCI baud rate 0	UCA1BR0	06h
USCI baud rate 1	UCA1BR1	07h
USCI modulation control	UCA1MCTL	08h
USCI status	UCA1STAT	0Ah
USCI receive buffer	UCA1RXBUF	0Ch
USCI transmit buffer	UCA1TXBUF	0Eh
USCI LIN control	UCA1ABCTL	10h
USCI IrDA transmit control	UCA1IRTCTL	12h
USCI IrDA receive control	UCA1IRRCTL	13h
USCI interrupt enable	UCA1IE	1Ch
USCI interrupt flags	UCA1IFG	1Dh
USCI interrupt vector word	UCA1IV	1Eh

Table 48. USCI_B1 Registers (Base Address: 0620h)

REGISTER DESCRIPTION	REGISTER	OFFSET
USCI synchronous control 0	UCB1CTL0	00h
USCI synchronous control 1	UCB1CTL1	01h
USCI synchronous bit rate 0	UCB1BR0	06h
USCI synchronous bit rate 1	UCB1BR1	07h
USCI synchronous status	UCB1STAT	0Ah
USCI synchronous receive buffer	UCB1RXBUF	0Ch
USCI synchronous transmit buffer	UCB1TXBUF	0Eh
USCI I2C own address	UCB1I2COA	10h
USCI I2C slave address	UCB1I2CSA	12h
USCI interrupt enable	UCB1IE	1Ch
USCI interrupt flags	UCB1IFG	1Dh
USCI interrupt vector word	UCB1IV	1Eh

Table 49. ADC12_A Registers (Base Address: 0700h)

REGISTER DESCRIPTION	REGISTER	OFFSET
Control register 0	ADC12CTL0	00h
Control register 1	ADC12CTL1	02h
Control register 2	ADC12CTL2	04h
Interrupt-flag register	ADC12IFG	0Ah
Interrupt-enable register	ADC12IE	0Ch
Interrupt-vector-word register	ADC12IV	0Eh
ADC memory-control register 0	ADC12MCTL0	10h
ADC memory-control register 1	ADC12MCTL1	11h
ADC memory-control register 2	ADC12MCTL2	12h
ADC memory-control register 3	ADC12MCTL3	13h
ADC memory-control register 4	ADC12MCTL4	14h
ADC memory-control register 5	ADC12MCTL5	15h
ADC memory-control register 6	ADC12MCTL6	16h
ADC memory-control register 7	ADC12MCTL7	17h
ADC memory-control register 8	ADC12MCTL8	18h

Table 49. ADC12_A Registers (Base Address: 0700h) (continued)

REGISTER DESCRIPTION	REGISTER	OFFSET
ADC memory-control register 9	ADC12MCTL9	19h
ADC memory-control register 10	ADC12MCTL10	1Ah
ADC memory-control register 11	ADC12MCTL11	1Bh
ADC memory-control register 12	ADC12MCTL12	1Ch
ADC memory-control register 13	ADC12MCTL13	1Dh
ADC memory-control register 14	ADC12MCTL14	1Eh
ADC memory-control register 15	ADC12MCTL15	1Fh
Conversion memory 0	ADC12MEM0	20h
Conversion memory 1	ADC12MEM1	22h
Conversion memory 2	ADC12MEM2	24h
Conversion memory 3	ADC12MEM3	26h
Conversion memory 4	ADC12MEM4	28h
Conversion memory 5	ADC12MEM5	2Ah
Conversion memory 6	ADC12MEM6	2Ch
Conversion memory 7	ADC12MEM7	2Eh
Conversion memory 8	ADC12MEM8	30h
Conversion memory 9	ADC12MEM9	32h
Conversion memory 10	ADC12MEM10	34h
Conversion memory 11	ADC12MEM11	36h
Conversion memory 12	ADC12MEM12	38h
Conversion memory 13	ADC12MEM13	3Ah
Conversion memory 14	ADC12MEM14	3Ch
Conversion memory 15	ADC12MEM15	3Eh

Table 50. DAC12_A Registers (Base Address: 0780h)

REGISTER DESCRIPTION	REGISTER	OFFSET
DAC12_A channel 0 control register 0	DAC12_0CTL0	00h
DAC12_A channel 0 control register 1	DAC12_0CTL1	02h
DAC12_A channel 0 data register	DAC12_0DAT	04h
DAC12_A channel 0 calibration control register	DAC12_0CALCTL	06h
DAC12_A channel 0 calibration data register	DAC12_0CALDAT	08h
DAC12_A channel 1 control register 0	DAC12_1CTL0	10h
DAC12_A channel 1 control register 1	DAC12_1CTL1	12h
DAC12_A channel 1 data register	DAC12_1DAT	14h
DAC12_A channel 1 calibration control register	DAC12_1CALCTL	16h
DAC12_A channel 1 calibration data register	DAC12_1CALDAT	18h
DAC12_A interrupt vector word	DAC12IV	1Eh

Table 51. Comparator_B Registers (Base Address: 08C0h)

REGISTER DESCRIPTION	REGISTER	OFFSET
Comp_B control register 0	CBCTL0	00h
Comp_B control register 1	CBCTL1	02h
Comp_B control register 2	CBCTL2	04h
Comp_B control register 3	CBCTL3	06h
Comp_B interrupt register	CBINT	0Ch
Comp_B interrupt vector word	CBIV	0Eh

Table 52. USB Configuration Registers (Base Address: 0900h)

REGISTER DESCRIPTION	REGISTER	OFFSET
USB key/ID	USBKEYID	00h
USB module configuration	USBCNF	02h
USB PHY control	USBPHYCTL	04h
USB power control	USBPWRCTL	08h
USB power voltage setting	USBPWRVSR	0Ah
USB PLL control	USBPLLCTL	10h
USB PLL divider	USBPLLDIV	12h
USB PLL interrupts	USBPLLIR	14h

Table 53. USB Control Registers (Base Address: 0920h)

REGISTER DESCRIPTION	REGISTER	OFFSET
Input endpoint#0 configuration	IEPCNF_0	00h
Input endpoint #0 byte count	IEPCNT_0	01h
Output endpoint#0 configuration	OEPDCF_0	02h
Output endpoint #0 byte count	OEPDCF_0	03h
Input endpoint interrupt enables	IEPIE	0Eh
Output endpoint interrupt enables	OEPPIE	0Fh
Input endpoint interrupt flags	IEPIFG	10h
Output endpoint interrupt flags	OEPPIFG	11h
USB interrupt vector	USBIV	12h
USB maintenance	MAINT	16h
Time stamp	TSREG	18h
USB frame number	USBFN	1Ah
USB control	USBCTL	1Ch
USB interrupt enables	USBIE	1Dh
USB interrupt flags	USBIFG	1Eh
Function address	FUNADR	1Fh

Table 54. LCD_B Registers (Base Address: 0A00h)

REGISTER DESCRIPTION	REGISTER	OFFSET
LCD_B control register 0	LCDBCTL0	000h
LCD_B control register 1	LCDBCTL1	002h
LCD_B blinking control register	LCDBBLKCTL	004h
LCD_B memory control register	LCDBMEMCTL	006h
LCD_B voltage control register	LCDBVCTL	008h
LCD_B port control register 0	LCDBPCTL0	00Ah
LCD_B port control register 1	LCDBPCTL1	00Ch
LCD_B port control register 2	LCDBPCTL2	00Eh
LCD_B charge pump control register	LCDBCTL0	012h
LCD_B interrupt vector word	LCDBIV	01Eh
LCD_B memory 1	LCDM1	020h
LCD_B memory 2	LCDM2	021h
...		
LCD_B memory 22	LCDM22	035h
LCD_B blinking memory 1	LCDBM1	040h
LCD_B blinking memory 2	LCDBM2	041h
...		

Table 54. LCD_B Registers (Base Address: 0A00h) (continued)

REGISTER DESCRIPTION	REGISTER	OFFSET
LCD_B blinking memory 22	LCDBM22	055h

Absolute Maximum Ratings⁽¹⁾

over operating free-air temperature range (unless otherwise noted)

Voltage applied at V_{CC} to V_{SS}	–0.3 V to 4.1 V
Voltage applied to any pin (excluding V _{CORE} , V _{BUS} , V18) ⁽²⁾	–0.3 V to $V_{CC} + 0.3$ V
Diode current at any device pin	±2 mA
Storage temperature range, T_{stg} ⁽³⁾	–55°C to 150°C
Maximum junction temperature, T_J	95°C

- (1) Stresses beyond those listed under "absolute maximum ratings" may cause permanent damage to the device. These are stress ratings only, and functional operation of the device at these or any other conditions beyond those indicated under "recommended operating conditions" is not implied. Exposure to absolute-maximum-rated conditions for extended periods may affect device reliability.
- (2) All voltages referenced to V_{SS} . V_{CORE} is for internal device usage only. No external dc loading or voltage should be applied.
- (3) Higher temperature may be applied during board soldering according to the current JEDEC J-STD-020 specification with peak reflow temperatures not higher than classified on the device label on the shipping boxes or reels.

Thermal Packaging Characteristics

PARAMETER			VALUE	UNIT
θ_{JA}	Junction-to-ambient thermal resistance, still air ⁽¹⁾	QFP (PZ)	122	°C/W
		BGA (ZQW)	108	
$\theta_{JC(TOP)}$	Junction-to-case (top) thermal resistance ⁽²⁾	QFP (PZ)	83	°C/W
		BGA (ZQW)	72	
θ_{JB}	Junction-to-board thermal resistance ⁽³⁾	QFP (PZ)	98	°C/W
		BGA (ZQW)	76	

- (1) The junction-to-ambient thermal resistance under natural convection is obtained in a simulation on a JEDEC-standard, High-K board, as specified in JESD51-7, in an environment described in JESD51-2a.
- (2) The junction-to-case(top) thermal resistance is obtained by simulating a cold plate test on the package top. No specific JEDEC-standard test exists, but a close description can be found in the ANSI SEMI standard G30-88.
- (3) The junction-to-board thermal resistance is obtained by simulating in an environment with a ring cold plate fixture to control the PCB temperature, as described in JESD51-8.

Recommended Operating Conditions

		MIN	NOM	MAX	UNIT	
V_{CC}	Supply voltage during program execution and flash programming (AVCC1 = DVCC1 = DVCC2 = DVCC3 = DVCC = V_{CC}) ⁽¹⁾	PMMCOREVx = 0	1.8	3.6	V	
		PMMCOREVx = 0, 1	2.0	3.6		
		PMMCOREVx = 0, 1, 2	2.2	3.6		
		PMMCOREVx = 0, 1, 2, 3	2.4	3.6		
$V_{CC, USB}$	Supply voltage during USB operation, USB PLL disabled USB_EN = 1, UPLLEN = 0	PMMCOREVx = 0	1.8	3.6	V	
		PMMCOREVx = 0, 1	2.0	3.6		
		PMMCOREVx = 0, 1, 2	2.2	3.6		
		PMMCOREVx = 0, 1, 2, 3	2.4	3.6		
	Supply voltage during USB operation, USB PLL enabled ⁽²⁾ USB_EN = 1, UPLLEN = 1	PMMCOREVx = 2	2.2	3.6		
		PMMCOREVx = 2, 3	2.4	3.6		
V_{SS}	Supply voltage (AVSS1 = AVSS2 = AVSS3 = DVSS1 = DVSS2 = DVSS3 = V_{SS})		0		V	
$V_{BAT, RTC}$	Backup-supply voltage with RTC operational	$T_A = 0^\circ\text{C}$ to 85°C	1.55	3.6	V	
		$T_A = -40^\circ\text{C}$ to 85°C	1.70	3.6		
$V_{BAT, MEM}$	Backup-supply voltage with backup memory retained.	$T_A = -40^\circ\text{C}$ to 85°C	1.20	3.6	V	
T_A	Operating free-air temperature	I version	–40	85	°C	
T_J	Operating junction temperature	I version	–40	85	°C	
C_{BAK}	Capacitance at pin VBAK		1	4.7	10	nF
C_{VCORE}	Capacitor at V _{CORE}			470		nF

- (1) It is recommended to power AV_{CC} and DV_{CC} from the same source. A maximum difference of 0.3 V between AV_{CC} and DV_{CC} can be tolerated during power up and operation.
- (2) USB operation with USB PLL enabled requires PMMCOREVx ≥ 2 for proper operation.

Recommended Operating Conditions (continued)

		MIN	NOM	MAX	UNIT
$C_{DVCC}/C_{V_{CORE}}$	Capacitor ratio of DVCC to V _{CORE}	10			
f_{SYSTEM}	Processor frequency (maximum MCLK frequency) ⁽³⁾ ⁽⁴⁾ (see Figure 1)	PMMCOREV _x = 0, 1.8 V ≤ V _{CC} ≤ 3.6 V (default condition)		0	8.0
		PMMCOREV _x = 1, 2 V ≤ V _{CC} ≤ 3.6 V		0	12.0
		PMMCOREV _x = 2, 2.2 V ≤ V _{CC} ≤ 3.6 V		0	16.0
		PMMCOREV _x = 3, 2.4 V ≤ V _{CC} ≤ 3.6 V		0	20.0
f_{SYSTEM_USB}	Minimum processor frequency for USB operation	1.5			MHz
USB_wait	Wait state cycles during USB operation		16		cycles

- (3) The MSP430 CPU is clocked directly with MCLK. Both the high and low phase of MCLK must not exceed the pulse width of the specified maximum frequency.
- (4) Modules may have a different maximum input clock specification. Refer to the specification of the respective module in this data sheet.

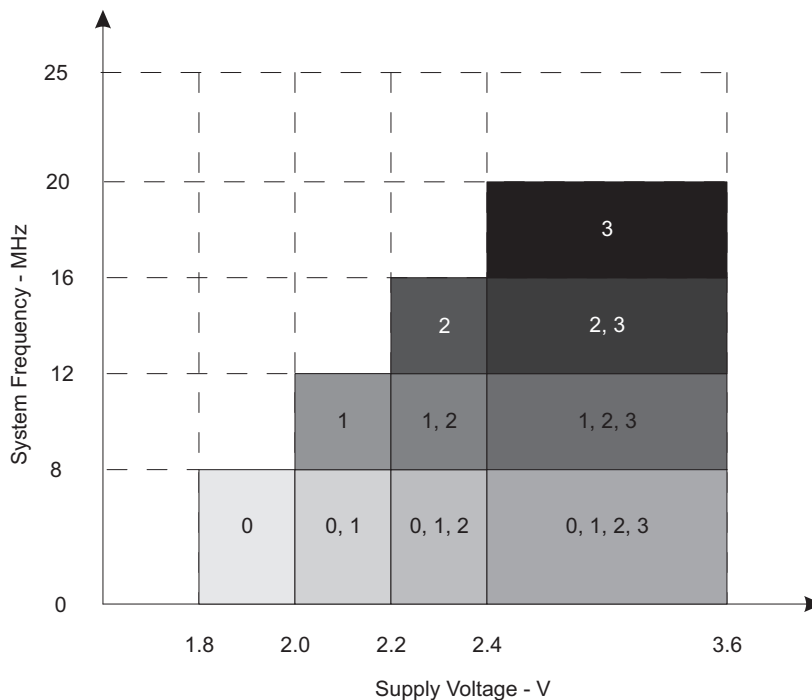

The numbers within the fields denote the supported PMMCOREV_x settings.

Figure 1. Frequency vs Supply Voltage

Electrical Characteristics

Active Mode Supply Current Into V_{CC} Excluding External Current

over recommended operating free-air temperature (unless otherwise noted)^{(1) (2) (3)}

PARAMETER	EXECUTION MEMORY	V_{CC}	PMMCOREVx	FREQUENCY ($f_{DCO} = f_{MCLK} = f_{SMCLK}$)								UNIT
				1 MHz		8 MHz		12 MHz		20 MHz		
				TYP	MAX	TYP	MAX	TYP	MAX	TYP	MAX	
$I_{AM, Flash}$	Flash	3 V	0	0.32	0.36	2.1	2.4					mA
			1	0.36		2.4		3.6	4.0			
			2	0.37		2.5		3.8				
			3	0.39		2.7		4.0		6.6		
$I_{AM, RAM}$	RAM	3 V	0	0.18	0.21	1.0	1.2					mA
			1	0.20		1.2		1.7	1.9			
			2	0.22		1.3		2.0				
			3	0.23		1.4		2.1		3.6		

(1) All inputs are tied to 0 V or to V_{CC} . Outputs do not source or sink any current.

(2) The currents are characterized with a Micro Crystal MS1V-T1K crystal with a load capacitance of 12.5 pF. The internal and external load capacitance are chosen to closely match the required 12.5 pF.

(3) Characterized with program executing typical data processing. USB disabled ($V_{USBEN} = 0$, $SLDOEN = 0$).

$f_{ACLK} = 32786$ Hz, $f_{DCO} = f_{MCLK} = f_{SMCLK}$ at specified frequency.

$XTS = CPUOFF = SCG0 = SCG1 = OSCOFF = SMCLKOFF = 0$.

Low-Power Mode Supply Currents (Into V_{CC}) Excluding External Current

over recommended ranges of supply voltage and operating free-air temperature (unless otherwise noted)^{(1) (2)}

PARAMETER	V_{CC}	PMMCOREVx	-40°C		25°C		60°C		85°C		UNIT
			TYP	MAX	TYP	MAX	TYP	MAX	TYP	MAX	
$I_{LPM0,1MHz}$ Low-power mode 0 ⁽³⁾⁽⁴⁾	2.2 V	0	71		75	87	81		85	99	μA
	3 V	3	78		83	98	89		94	108	
I_{LPM2} Low-power mode 2 ⁽⁵⁾⁽⁴⁾	2.2 V	0	6.3		6.7	9.9	9.0		11	16	μA
	3 V	3	6.6		7.0	11	10		12	18	
$I_{LPM3,XT1LF}$ Low-power mode 3, crystal mode ⁽⁶⁾⁽⁴⁾	2.2 V	0	1.6		1.8	2.4	4.7		6.5	10.5	μA
		1	1.6		1.9		4.8		6.6		
		2	1.7		2.0		4.9		6.7		
	3 V	0	1.9		2.1	2.7	5.0		6.8	10.8	
		1	1.9		2.1		5.1		7.0		
		2	2.0		2.2		5.2		7.1		
$I_{LPM3,VLO,WDT}$ Low-power mode 3, VLO mode, Watchdog enabled ⁽⁷⁾⁽⁴⁾	3 V	3	2.0		2.2	2.9	5.4		7.3	12.6	
		0	0.9		1.2	1.9	4.0		5.9	10.3	
		1	0.9		1.2		4.1		6.0		
		2	1.0		1.3		4.2		6.1		
I_{LPM4} Low-power mode 4 ⁽⁸⁾⁽⁴⁾	3 V	3	1.0		1.3	2.2	4.3		6.3	11.3	
		0	0.9		1.1	1.8	3.9		5.8	10	
		1	0.9		1.1		4.0		5.9		
		2	1.0		1.2		4.1		6.1		
$I_{LPM3.5,RTC,VCC}$ Low-power mode 3.5 (LPM3.5) current with active RTC into primary supply pin DV_{CC} ⁽⁹⁾	3 V	3			0.5				0.8	1.4	μA
		0									
$I_{LPM3.5,RTC,VBAT}$ Low-power mode 3.5 (LPM3.5) current with active RTC into backup supply pin VBAT ⁽¹⁰⁾	3 V	3			0.6				0.8	1.4	μA
		0									
$I_{LPM3.5,RTC,TOT}$ Total low-power mode 3.5 (LPM3.5) current with active RTC ⁽¹¹⁾	3 V		1.0		1.1		1.3		1.6	2.8	μA

(1) All inputs are tied to 0 V or to V_{CC} . Outputs do not source or sink any current.

(2) The currents are characterized with a Micro Crystal CC4V-T1A SMD crystal with a load capacitance of 9 pF. The internal and external load capacitance are chosen to closely match the required 9 pF.

(3) Current for watchdog timer clocked by SMCLK included. ACLK = low frequency crystal operation (XTS = 0, XT1DRIVEx = 0). CPUOFF = 1, SCG0 = 0, SCG1 = 0, OSCOFF = 0 (LPM0); f_{ACLK} = 32768 Hz, f_{MCLK} = 0 MHz, f_{SMCLK} = f_{DCO} = 1 MHz USB disabled (VUSBEN = 0, SLDOEN = 0).

(4) Current for brownout included. Low side supervisor and monitors disabled (SVSL, SVM_L). High side supervisor and monitor disabled (SVSH, SVM_H). RAM retention enabled.

(5) Current for watchdog timer clocked by ACLK and RTC clocked by LFXT1 (32768 Hz) included. ACLK = low frequency crystal operation (XTS = 0, XT1DRIVEx = 0). CPUOFF = 1, SCG0 = 0, SCG1 = 1, OSCOFF = 0 (LPM2); f_{ACLK} = 32768 Hz, f_{MCLK} = 0 MHz, f_{SMCLK} = f_{DCO} = 0 MHz; DCO setting = 1 MHz operation, DCO bias generator enabled. USB disabled (VUSBEN = 0, SLDOEN = 0).

(6) Current for watchdog timer clocked by ACLK and RTC clocked by LFXT1 (32768 Hz) included. ACLK = low frequency crystal operation (XTS = 0, XT1DRIVEx = 0). CPUOFF = 1, SCG0 = 1, SCG1 = 1, OSCOFF = 0 (LPM3); f_{ACLK} = 32768 Hz, f_{MCLK} = f_{SMCLK} = f_{DCO} = 0 MHz USB disabled (VUSBEN = 0, SLDOEN = 0).

(7) Current for watchdog timer clocked by VLO included. CPUOFF = 1, SCG0 = 1, SCG1 = 1, OSCOFF = 0 (LPM3); f_{ACLK} = f_{MCLK} = f_{SMCLK} = f_{DCO} = 0 MHz USB disabled (VUSBEN = 0, SLDOEN = 0).

(8) CPUOFF = 1, SCG0 = 1, SCG1 = 1, OSCOFF = 1 (LPM4); f_{DCO} = f_{ACLK} = f_{MCLK} = f_{SMCLK} = 0 MHz USB disabled (VUSBEN = 0, SLDOEN = 0).

(9) V_{VBAT} = V_{CC} - 0.2 V, f_{DCO} = f_{MCLK} = f_{SMCLK} = 0 MHz, f_{ACLK} = 32768 Hz, PMMREGOFF = 1, RTC in backup domain active

(10) V_{VBAT} = V_{CC} - 0.2 V, f_{DCO} = f_{MCLK} = f_{SMCLK} = 0 MHz, f_{ACLK} = 32768 Hz, PMMREGOFF = 1, RTC in backup domain active, no current drawn on VBAK

(11) f_{DCO} = f_{MCLK} = f_{SMCLK} = 0 MHz, f_{ACLK} = 32768 Hz, PMMREGOFF = 1, RTC in backup domain active, no current drawn on VBAK

Low-Power Mode Supply Currents (Into V_{CC}) Excluding External Current (continued)

over recommended ranges of supply voltage and operating free-air temperature (unless otherwise noted)^{(1) (2)}

PARAMETER	V_{CC}	PMMCOREVx	-40°C		25°C		60°C		85°C		UNIT
			TYP	MAX	TYP	MAX	TYP	MAX	TYP	MAX	
$I_{LPM4.5}$ Low-power mode 4.5 (LPM4.5) ⁽¹²⁾	3 V		0.2		0.3	0.6	0.7		0.9	1.4	μ A

(12) Internal regulator disabled. No data retention.

CPUOFF = 1, SCG0 = 1, SCG1 = 1, OSCOFF = 1, PMMREGOFF = 1 (LPM4.5); $f_{DCO} = f_{ACLK} = f_{MCLK} = f_{SMCLK} = 0$ MHz

Low-Power Mode With LCD Supply Currents (Into V_{CC}) Excluding External Current

over recommended ranges of supply voltage and operating free-air temperature (unless otherwise noted)^{(1) (2)}

PARAMETER	V_{CC}	PMMCOREVx	Temperature (T_A)								UNIT
			-40°C		25°C		60°C		85°C		
			TYP	MAX	TYP	MAX	TYP	MAX	TYP	MAX	
$I_{LPM3, LCD, ext. bias}$ Low-power mode 3 (LPM3) current, LCD 4-mux mode, external biasing ^{(3) (4)}	3 V	0	2.3		2.7	3.1	5.4		7.4	11.5	μ A
		1	2.3		2.7		5.6		7.5		
		2	2.4		2.8		5.8		7.7		
		3	2.4		2.8	3.5	5.9		7.9	13.2	
$I_{LPM3, LCD, int. bias}$ Low-power mode 3 (LPM3) current, LCD 4-mux mode, internal biasing, charge pump disabled ^{(3) (5)}	3 V	0	2.7		3.2	3.8	5.9		7.9	12.2	μ A
		1	2.7		3.2		6.1		8.1		
		2	2.8		3.3		6.2		8.3		
		3	2.8		3.3	4.9	6.4		8.4	13.7	
$I_{LPM3, LCD, CP}$ Low-power mode 3 (LPM3) current, LCD 4-mux mode, internal biasing, charge pump enabled ^{(3) (6)}	2.2 V	0			3.8						μ A
		1			3.9						
		2			4.0						
	3 V	0			4.0						μ A
		1			4.1						
		2			4.2						
		3			4.2						
		3			4.2						

(1) All inputs are tied to 0 V or to V_{CC} . Outputs do not source or sink any current.

(2) The currents are characterized with a Micro Crystal CC4V-T1A SMD crystal with a load capacitance of 9 pF. The internal and external load capacitance are chosen to closely match the required 9 pF.

(3) Current for watchdog timer clocked by ACLK and RTC clocked by LFX1 (32768 Hz) included. ACLK = low frequency crystal operation (XTS = 0, XT1DRIVEx = 0).

CPUOFF = 1, SCG0 = 1, SCG1 = 1, OSCOFF = 0 (LPM3); $f_{ACLK} = 32768$ Hz, $f_{MCLK} = f_{SMCLK} = f_{DCO} = 0$ MHz

Current for brownout included. Low side supervisor and monitors disabled (SVSL, SVM_L). High side supervisor and monitor disabled (SVSH, SVM_H). RAM retention enabled.

(4) LCDMx = 11 (4-mux mode), LCDREXT = 1, LCDEXTBIAS = 1 (external biasing), LCD2B = 0 (1/3 bias), LCDPEN = 0 (charge pump disabled), LCDSSEL = 0, LCDPREx = 101, LCDDIVx = 00011 ($f_{LCD} = 32768$ Hz/32/4 = 256 Hz)

Current through external resistors not included (voltage levels are supplied by test equipment).

Even segments S0, S2, ... = 0, odd segments S1, S3, ... = 1. No LCD panel load.

(5) LCDMx = 11 (4-mux mode), LCDREXT = 0, LCDEXTBIAS = 0 (internal biasing), LCD2B = 0 (1/3 bias), LCDPEN = 0 (charge pump disabled), LCDSSEL = 0, LCDPREx = 101, LCDDIVx = 00011 ($f_{LCD} = 32768$ Hz/32/4 = 256 Hz)

Even segments S0, S2, ... = 0, odd segments S1, S3, ... = 1. No LCD panel load.

(6) LCDMx = 11 (4-mux mode), LCDREXT = 0, LCDEXTBIAS = 0 (internal biasing), LCD2B = 0 (1/3 bias), LCDPEN = 1 (charge pump enabled), VLCDx = 1000 ($V_{LCD} = 3$ V, typ.), LCDSSEL = 0, LCDPREx = 101, LCDDIVx = 00011 ($f_{LCD} = 32768$ Hz/32/4 = 256 Hz)

Even segments S0, S2, ... = 0, odd segments S1, S3, ... = 1. No LCD panel load.

Schmitt-Trigger Inputs – General Purpose I/O⁽¹⁾

over recommended ranges of supply voltage and operating free-air temperature (unless otherwise noted)

PARAMETER	TEST CONDITIONS	V_{CC}	MIN	TYP	MAX	UNIT
V_{IT+} Positive-going input threshold voltage		1.8 V	0.80		1.40	V
		3 V	1.50		2.10	

(1) Same parametrics apply to clock input pin when crystal bypass mode is used on XT1 (XIN) or XT2 (XT2IN).

Schmitt-Trigger Inputs – General Purpose I/O⁽¹⁾ (continued)

over recommended ranges of supply voltage and operating free-air temperature (unless otherwise noted)

PARAMETER	TEST CONDITIONS	V _{CC}	MIN	TYP	MAX	UNIT
V _{IT-} Negative-going input threshold voltage		1.8 V	0.45		1.00	V
		3 V	0.75		1.65	
V _{hys} Input voltage hysteresis (V _{IT+} – V _{IT-})		1.8 V	0.3		0.8	V
		3 V	0.4		1.0	
R _{Pull} Pullup/pulldown resistor	For pullup: V _{IN} = V _{SS} For pulldown: V _{IN} = V _{CC}		20	35	50	kΩ
C _I Input capacitance	V _{IN} = V _{SS} or V _{CC}			5		pF

Inputs – Ports P1, P2, P3, and P4⁽¹⁾

over recommended ranges of supply voltage and operating free-air temperature (unless otherwise noted)

PARAMETER	TEST CONDITIONS	V _{CC}	MIN	MAX	UNIT
t _(int) External interrupt timing ⁽²⁾	Port P1, P2, P3, P4: P1.x to P4.x, External trigger pulse width to set interrupt flag	2.2 V/3 V	20		ns

- (1) Some devices may contain additional ports with interrupts. See the block diagram and terminal function descriptions.
(2) An external signal sets the interrupt flag every time the minimum interrupt pulse width t_(int) is met. It may be set by trigger signals shorter than t_(int).

Leakage Current – General Purpose I/O

over recommended ranges of supply voltage and operating free-air temperature (unless otherwise noted)

PARAMETER	TEST CONDITIONS	V _{CC}	MIN	MAX	UNIT
I _{lkg(Px.x)} High-impedance leakage current	(1) (2)	1.8 V/3 V		±50	nA

- (1) The leakage current is measured with V_{SS} or V_{CC} applied to the corresponding pin(s), unless otherwise noted.
(2) The leakage of the digital port pins is measured individually. The port pin is selected for input and the pullup/pulldown resistor is disabled.

Outputs – General Purpose I/O (Full Drive Strength)

over recommended ranges of supply voltage and operating free-air temperature (unless otherwise noted)

PARAMETER	TEST CONDITIONS	V _{CC}	MIN	MAX	UNIT
V _{OH} High-level output voltage	I _(OHmax) = –3 mA ⁽¹⁾	1.8 V	V _{CC} – 0.25	V _{CC}	V
	I _(OHmax) = –10 mA ⁽²⁾		V _{CC} – 0.60	V _{CC}	
	I _(OHmax) = –5 mA ⁽¹⁾	3 V	V _{CC} – 0.25	V _{CC}	
	I _(OHmax) = –15 mA ⁽²⁾		V _{CC} – 0.60	V _{CC}	
V _{OL} Low-level output voltage	I _(OLmax) = 3 mA ⁽¹⁾	1.8 V	V _{SS}	V _{SS} + 0.25	V
	I _(OLmax) = 10 mA ⁽²⁾		V _{SS}	V _{SS} + 0.60	
	I _(OLmax) = 5 mA ⁽¹⁾	3 V	V _{SS}	V _{SS} + 0.25	
	I _(OLmax) = 15 mA ⁽²⁾		V _{SS}	V _{SS} + 0.60	

- (1) The maximum total current, I_(OHmax) and I_(OLmax), for all outputs combined should not exceed ±48 mA to hold the maximum voltage drop specified.
(2) The maximum total current, I_(OHmax) and I_(OLmax), for all outputs combined should not exceed ±100 mA to hold the maximum voltage drop specified.

Outputs – General Purpose I/O (Reduced Drive Strength)

over recommended ranges of supply voltage and operating free-air temperature (unless otherwise noted)⁽¹⁾

PARAMETER		TEST CONDITIONS	V _{CC}	MIN	MAX	UNIT
V _{OH}	High-level output voltage	I _(OHmax) = -1 mA ⁽²⁾	1.8 V	V _{CC} - 0.25	V _{CC}	V
		I _(OHmax) = -3 mA ⁽³⁾		V _{CC} - 0.60	V _{CC}	
		I _(OHmax) = -2 mA ⁽²⁾	3 V	V _{CC} - 0.25	V _{CC}	
		I _(OHmax) = -6 mA ⁽³⁾		V _{CC} - 0.60	V _{CC}	
V _{OL}	Low-level output voltage	I _(OLmax) = 1 mA ⁽²⁾	1.8 V	V _{SS}	V _{SS} + 0.25	V
		I _(OLmax) = 3 mA ⁽³⁾		V _{SS}	V _{SS} + 0.60	
		I _(OLmax) = 2 mA ⁽²⁾	3 V	V _{SS}	V _{SS} + 0.25	
		I _(OLmax) = 6 mA ⁽³⁾		V _{SS}	V _{SS} + 0.60	

(1) Selecting reduced drive strength may reduce EMI.

(2) The maximum total current, I_(OHmax) and I_(OLmax), for all outputs combined, should not exceed ±48 mA to hold the maximum voltage drop specified.

(3) The maximum total current, I_(OHmax) and I_(OLmax), for all outputs combined, should not exceed ±100 mA to hold the maximum voltage drop specified.

Output Frequency – Ports P1, P2 and P3

over recommended ranges of supply voltage and operating free-air temperature (unless otherwise noted)

PARAMETER		TEST CONDITIONS	MIN	MAX	UNIT
f _{Px,y}	Port output frequency (with load)	P3.4/TA2CLK/SMCLK/S27 C _L = 20 pF, R _L = 1 kΩ ⁽¹⁾ or 3.2 kΩ ⁽²⁾ (3)	V _{CC} = 1.8 V PMMCOREVx = 0	8	MHz
			V _{CC} = 3 V PMMCOREVx = 3	20	
f _{Port_CLK}	Clock output frequency	P1.0/TA0CLK/ACLK/S39 P3.4/TA2CLK/SMCLK/S27 P2.0/P2MAP0 (P2MAP0 = PM_MCLK) C _L = 20 pF ⁽³⁾	V _{CC} = 1.8 V PMMCOREVx = 0	8	MHz
			V _{CC} = 3 V PMMCOREVx = 3	20	

(1) Full drive strength of port: A resistive divider with 2 × 0.5 kΩ between V_{CC} and V_{SS} is used as load. The output is connected to the center tap of the divider.

(2) Reduced drive strength of port: A resistive divider with 2 × 1.6 kΩ between V_{CC} and V_{SS} is used as load. The output is connected to the center tap of the divider.

(3) The output voltage reaches at least 10% and 90% V_{CC} at the specified toggle frequency.

Typical Characteristics – Outputs, Reduced Drive Strength (PxDS.y = 0)

over recommended ranges of supply voltage and operating free-air temperature (unless otherwise noted)

TYPICAL LOW-LEVEL OUTPUT CURRENT vs LOW-LEVEL OUTPUT VOLTAGE

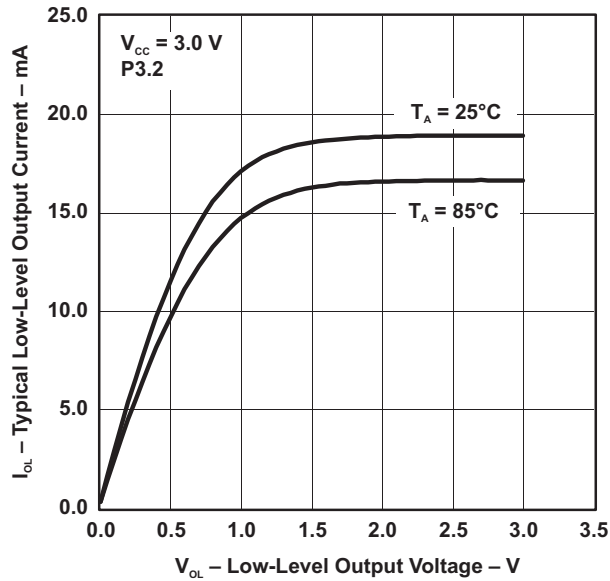

Figure 2.

TYPICAL LOW-LEVEL OUTPUT CURRENT vs LOW-LEVEL OUTPUT VOLTAGE

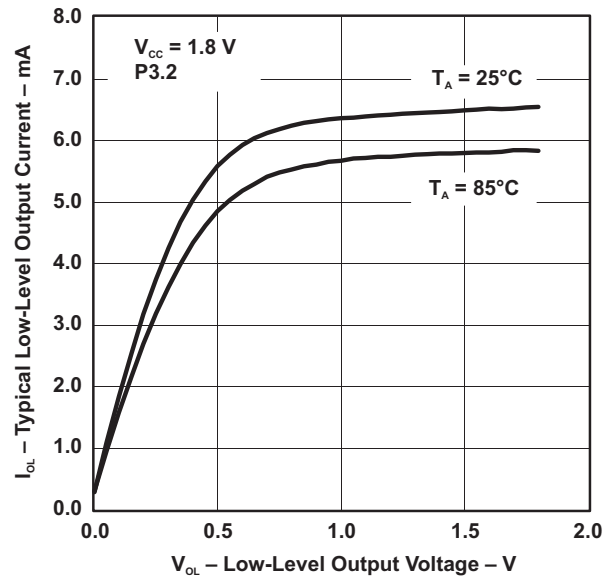

Figure 3.

TYPICAL HIGH-LEVEL OUTPUT CURRENT vs HIGH-LEVEL OUTPUT VOLTAGE

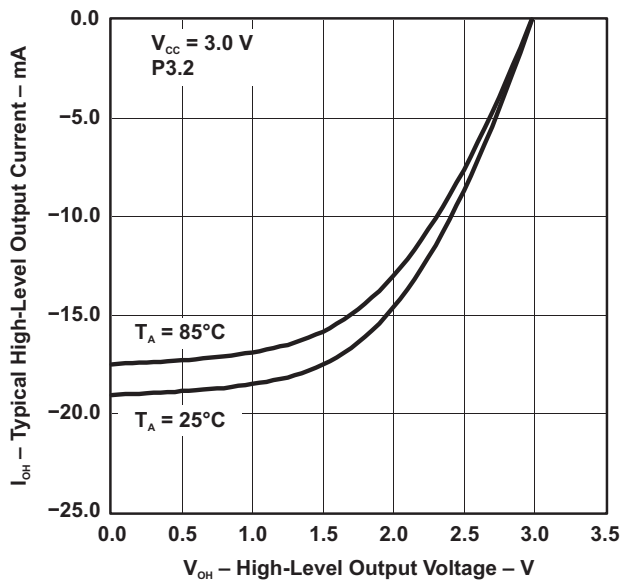

Figure 4.

TYPICAL HIGH-LEVEL OUTPUT CURRENT vs HIGH-LEVEL OUTPUT VOLTAGE

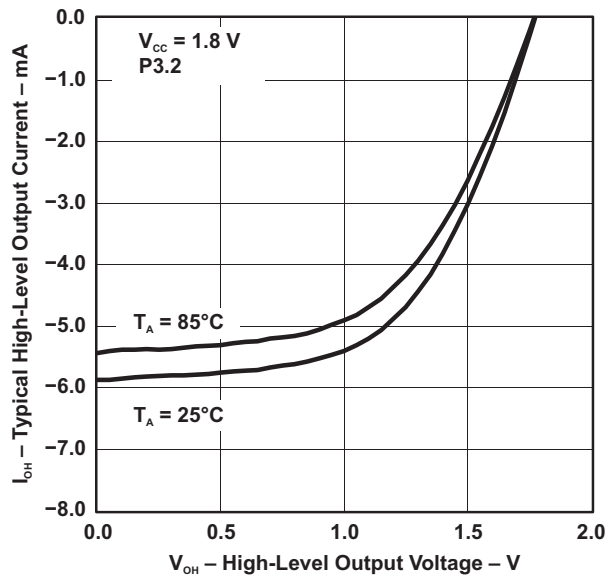
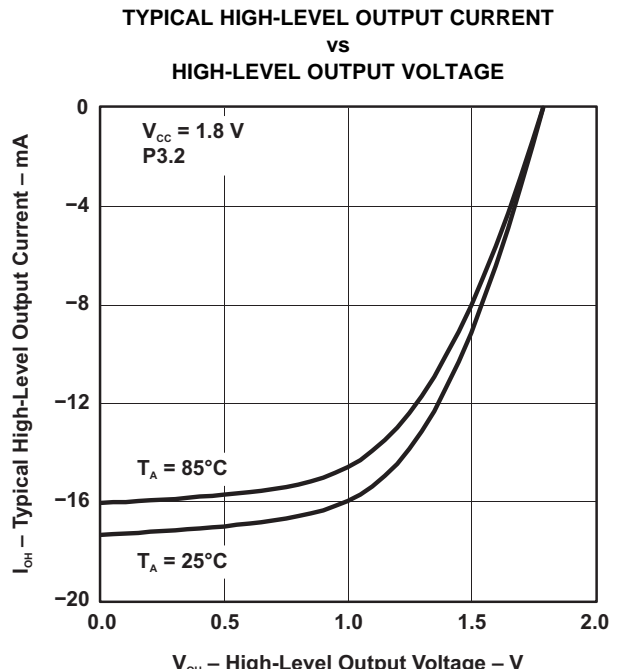
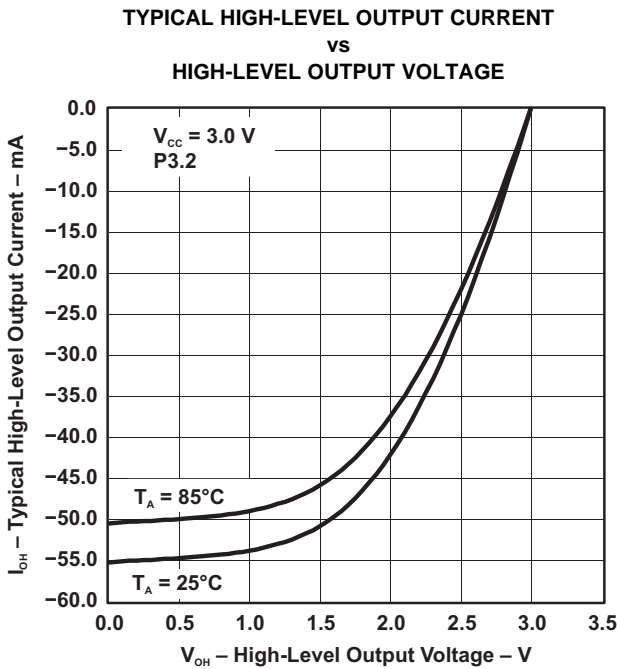
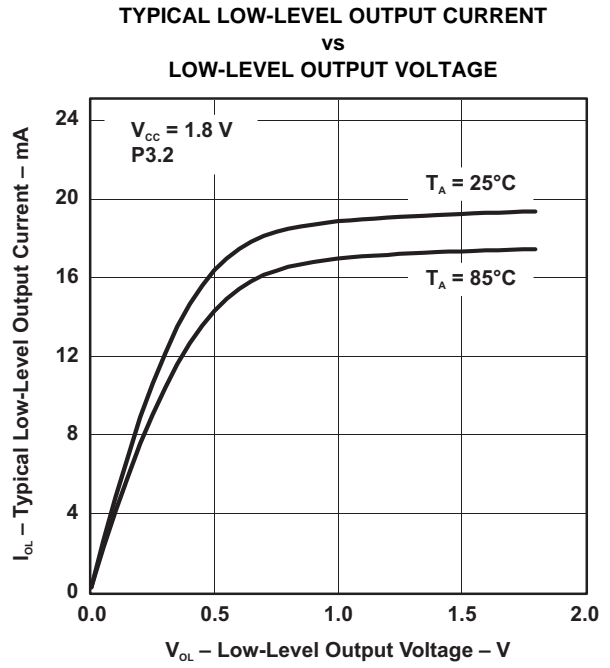
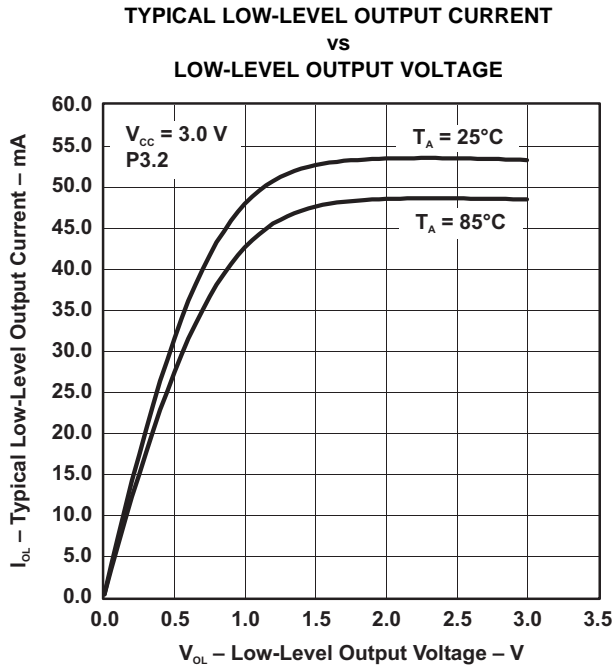

Figure 5.

Typical Characteristics – Outputs, Full Drive Strength (PxDS.y = 1)

over recommended ranges of supply voltage and operating free-air temperature (unless otherwise noted)



Crystal Oscillator, XT1, Low-Frequency Mode⁽¹⁾

over recommended ranges of supply voltage and operating free-air temperature (unless otherwise noted)

PARAMETER		TEST CONDITIONS	V _{CC}	MIN	TYP	MAX	UNIT
$\Delta I_{DVCC,LF}$	Differential XT1 oscillator crystal current consumption from lowest drive setting, LF mode	$f_{OSC} = 32768$ Hz, XTS = 0, XT1BYPASS = 0, XT1DRIVE _x = 1, T _A = 25°C	3 V	0.075		μA	
		$f_{OSC} = 32768$ Hz, XTS = 0, XT1BYPASS = 0, XT1DRIVE _x = 2, T _A = 25°C		0.170			
		$f_{OSC} = 32768$ Hz, XTS = 0, XT1BYPASS = 0, XT1DRIVE _x = 3, T _A = 25°C		0.290			
$f_{XT1,LF0}$	XT1 oscillator crystal frequency, LF mode	XTS = 0, XT1BYPASS = 0		32768		Hz	
$f_{XT1,LF,SW}$	XT1 oscillator logic-level square-wave input frequency, LF mode	XTS = 0, XT1BYPASS = 1 ⁽²⁾ ⁽³⁾		10	32.768	50	kHz
O _{A,LF}	Oscillation allowance for LF crystals ⁽⁴⁾	XTS = 0, XT1BYPASS = 0, XT1DRIVE _x = 0, $f_{XT1,LF} = 32768$ Hz, C _{L,eff} = 6 pF		210		kΩ	
		XTS = 0, XT1BYPASS = 0, XT1DRIVE _x = 1, $f_{XT1,LF} = 32768$ Hz, C _{L,eff} = 12 pF		300			
C _{L,eff}	Integrated effective load capacitance, LF mode ⁽⁵⁾	XTS = 0, XCAP _x = 0 ⁽⁶⁾		2		pF	
		XTS = 0, XCAP _x = 1		5.5			
		XTS = 0, XCAP _x = 2		8.5			
		XTS = 0, XCAP _x = 3		12.0			
	Duty cycle, LF mode	XTS = 0, Measured at ACLK, $f_{XT1,LF} = 32768$ Hz		30		70	%
$f_{Fault,LF}$	Oscillator fault frequency, LF mode ⁽⁷⁾	XTS = 0 ⁽⁸⁾		10		10000	Hz
$t_{START,LF}$	Startup time, LF mode	$f_{OSC} = 32768$ Hz, XTS = 0, XT1BYPASS = 0, XT1DRIVE _x = 0, T _A = 25°C, C _{L,eff} = 6 pF	3 V	1000		ms	
		$f_{OSC} = 32768$ Hz, XTS = 0, XT1BYPASS = 0, XT1DRIVE _x = 3, T _A = 25°C, C _{L,eff} = 12 pF		500			

- (1) To improve EMI on the XT1 oscillator, the following guidelines should be observed.
 - (a) Keep the trace between the device and the crystal as short as possible.
 - (b) Design a good ground plane around the oscillator pins.
 - (c) Prevent crosstalk from other clock or data lines into oscillator pins XIN and XOUT.
 - (d) Avoid running PCB traces underneath or adjacent to the XIN and XOUT pins.
 - (e) Use assembly materials and praxis to avoid any parasitic load on the oscillator XIN and XOUT pins.
 - (f) If conformal coating is used, ensure that it does not induce capacitive/resistive leakage between the oscillator pins.
- (2) When XT1BYPASS is set, XT1 circuit is automatically powered down. Input signal is a digital square wave with parametrics defined in the Schmitt-trigger Inputs section of this datasheet.
- (3) Maximum frequency of operation of the entire device cannot be exceeded.
- (4) Oscillation allowance is based on a safety factor of 5 for recommended crystals. The oscillation allowance is a function of the XT1DRIVE_x settings and the effective load. In general, comparable oscillator allowance can be achieved based on the following guidelines, but should be evaluated based on the actual crystal selected for the application:
 - (a) For XT1DRIVE_x = 0, C_{L,eff} ≤ 6 pF.
 - (b) For XT1DRIVE_x = 1, 6 pF ≤ C_{L,eff} ≤ 9 pF.
 - (c) For XT1DRIVE_x = 2, 6 pF ≤ C_{L,eff} ≤ 10 pF.
 - (d) For XT1DRIVE_x = 3, C_{L,eff} ≥ 6 pF.
- (5) Includes parasitic bond and package capacitance (approximately 2 pF per pin).
Since the PCB adds additional capacitance, it is recommended to verify the correct load by measuring the ACLK frequency. For a correct setup, the effective load capacitance should always match the specification of the used crystal.
- (6) Requires external capacitors at both terminals. Values are specified by crystal manufacturers.
- (7) Frequencies below the MIN specification set the fault flag. Frequencies above the MAX specification do not set the fault flag. Frequencies in between might set the flag.
- (8) Measured with logic-level input frequency but also applies to operation with crystals.

Crystal Oscillator, XT2

over recommended ranges of supply voltage and operating free-air temperature (unless otherwise noted)^{(1) (2)}

PARAMETER		TEST CONDITIONS	V _{CC}	MIN	TYP	MAX	UNIT
I _{DVCC,XT2}	XT2 oscillator crystal current consumption	f _{OSC} = 4 MHz, XT2OFF = 0, XT2BYPASS = 0, XT2DRIVE _x = 0, T _A = 25°C	3 V		200		μA
		f _{OSC} = 12 MHz, XT2OFF = 0, XT2BYPASS = 0, XT2DRIVE _x = 1, T _A = 25°C			260		
		f _{OSC} = 20 MHz, XT2OFF = 0, XT2BYPASS = 0, XT2DRIVE _x = 2, T _A = 25°C			325		
		f _{OSC} = 32 MHz, XT2OFF = 0, XT2BYPASS = 0, XT2DRIVE _x = 3, T _A = 25°C			450		
f _{XT2,HF0}	XT2 oscillator crystal frequency, mode 0	XT2DRIVE _x = 0, XT2BYPASS = 0 ⁽³⁾		4		8	MHz
f _{XT2,HF1}	XT2 oscillator crystal frequency, mode 1	XT2DRIVE _x = 1, XT2BYPASS = 0 ⁽³⁾		8		16	MHz
f _{XT2,HF2}	XT2 oscillator crystal frequency, mode 2	XT2DRIVE _x = 2, XT2BYPASS = 0 ⁽³⁾		16		24	MHz
f _{XT2,HF3}	XT2 oscillator crystal frequency, mode 3	XT2DRIVE _x = 3, XT2BYPASS = 0 ⁽³⁾		24		32	MHz
f _{XT2,HF,SW}	XT2 oscillator logic-level square-wave input frequency	XT2BYPASS = 1 ^{(4) (3)}		0.7		32	MHz
O _{AHF}	Oscillation allowance for HF crystals ⁽⁵⁾	XT2DRIVE _x = 0, XT2BYPASS = 0, f _{XT2,HF0} = 6 MHz, C _{L,eff} = 15 pF			450		Ω
		XT2DRIVE _x = 1, XT2BYPASS = 0, f _{XT2,HF1} = 12 MHz, C _{L,eff} = 15 pF			320		
		XT2DRIVE _x = 2, XT2BYPASS = 0, f _{XT2,HF2} = 20 MHz, C _{L,eff} = 15 pF			200		
		XT2DRIVE _x = 3, XT2BYPASS = 0, f _{XT2,HF3} = 32 MHz, C _{L,eff} = 15 pF			200		
t _{START,HF}	Startup time	f _{OSC} = 6 MHz XT2BYPASS = 0, XT2DRIVE _x = 0, T _A = 25°C, C _{L,eff} = 15 pF	3 V		0.5		ms
		f _{OSC} = 20 MHz XT2BYPASS = 0, XT2DRIVE _x = 3, T _A = 25°C, C _{L,eff} = 15 pF				0.3	
C _{L,eff}	Integrated effective load capacitance, HF mode ^{(6) (1)}				1		pF
	Duty cycle	Measured at ACLK, f _{XT2,HF2} = 20 MHz		40	50	60	%
f _{Fault,HF}	Oscillator fault frequency ⁽⁷⁾	XT2BYPASS = 1 ⁽⁸⁾		30		300	kHz

(1) Requires external capacitors at both terminals. Values are specified by crystal manufacturers.

(2) To improve EMI on the XT2 oscillator the following guidelines should be observed.

(a) Keep the traces between the device and the crystal as short as possible.

(b) Design a good ground plane around the oscillator pins.

(c) Prevent crosstalk from other clock or data lines into oscillator pins XT2IN and XT2OUT.

(d) Avoid running PCB traces underneath or adjacent to the XT2IN and XT2OUT pins.

(e) Use assembly materials and praxis to avoid any parasitic load on the oscillator XT2IN and XT2OUT pins.

(f) If conformal coating is used, ensure that it does not induce capacitive/resistive leakage between the oscillator pins.

(3) Maximum frequency of operation of the entire device cannot be exceeded.

(4) When XT2BYPASS is set, the XT2 circuit is automatically powered down.

(5) Oscillation allowance is based on a safety factor of 5 for recommended crystals.

(6) Includes parasitic bond and package capacitance (approximately 2 pF per pin).

Since the PCB adds additional capacitance, it is recommended to verify the correct load by measuring the ACLK frequency. For a correct setup, the effective load capacitance should always match the specification of the used crystal.

(7) Frequencies below the MIN specification set the fault flag. Frequencies above the MAX specification do not set the fault flag. Frequencies in between might set the flag.

(8) Measured with logic-level input frequency but also applies to operation with crystals.

Internal Very-Low-Power Low-Frequency Oscillator (VLO)

over recommended ranges of supply voltage and operating free-air temperature (unless otherwise noted)

PARAMETER		TEST CONDITIONS	V _{CC}	MIN	TYP	MAX	UNIT
f _{VLO}	VLO frequency	Measured at ACLK	1.8 V to 3.6 V	6	9.4	14	kHz
df _{VLO} /dT	VLO frequency temperature drift	Measured at ACLK ⁽¹⁾	1.8 V to 3.6 V		0.5		%/°C
df _{VLO} /dV _{CC}	VLO frequency supply voltage drift	Measured at ACLK ⁽²⁾	1.8 V to 3.6 V		4		%/V
	Duty cycle	Measured at ACLK	1.8 V to 3.6 V	40	50	60	%

(1) Calculated using the box method: (MAX(-40 to 85°C) – MIN(-40 to 85°C)) / MIN(-40 to 85°C) / (85°C – (-40°C))

(2) Calculated using the box method: (MAX(1.8 to 3.6 V) – MIN(1.8 to 3.6 V)) / MIN(1.8 to 3.6 V) / (3.6 V – 1.8 V)

Internal Reference, Low-Frequency Oscillator (REFO)

over recommended ranges of supply voltage and operating free-air temperature (unless otherwise noted)

PARAMETER		TEST CONDITIONS	V _{CC}	MIN	TYP	MAX	UNIT
I _{REFO}	REFO oscillator current consumption	T _A = 25°C	1.8 V to 3.6 V		3		μA
f _{REFO}	REFO frequency calibrated	Measured at ACLK	1.8 V to 3.6 V		32768		Hz
	REFO absolute tolerance calibrated	Full temperature range	1.8 V to 3.6 V			±3.5	%
		T _A = 25°C	3 V			±1.5	%
df _{REFO} /dT	REFO frequency temperature drift	Measured at ACLK ⁽¹⁾	1.8 V to 3.6 V		0.01		%/°C
df _{REFO} /dV _{CC}	REFO frequency supply voltage drift	Measured at ACLK ⁽²⁾	1.8 V to 3.6 V		1.0		%/V
	Duty cycle	Measured at ACLK	1.8 V to 3.6 V	40	50	60	%
t _{START}	REFO startup time	40%/60% duty cycle	1.8 V to 3.6 V		25		μs

(1) Calculated using the box method: (MAX(-40 to 85°C) – MIN(-40 to 85°C)) / MIN(-40 to 85°C) / (85°C – (-40°C))

(2) Calculated using the box method: (MAX(1.8 to 3.6 V) – MIN(1.8 to 3.6 V)) / MIN(1.8 to 3.6 V) / (3.6 V – 1.8 V)

DCO Frequency

over recommended ranges of supply voltage and operating free-air temperature (unless otherwise noted)

PARAMETER	TEST CONDITIONS	MIN	TYP	MAX	UNIT	
$f_{DCO(0,0)}$	DCO frequency (0, 0)	DCORSELx = 0, DCOx = 0, MODx = 0	0.07	0.20	MHz	
$f_{DCO(0,31)}$	DCO frequency (0, 31)	DCORSELx = 0, DCOx = 31, MODx = 0	0.70	1.70	MHz	
$f_{DCO(1,0)}$	DCO frequency (1, 0)	DCORSELx = 1, DCOx = 0, MODx = 0	0.15	0.36	MHz	
$f_{DCO(1,31)}$	DCO frequency (1, 31)	DCORSELx = 1, DCOx = 31, MODx = 0	1.47	3.45	MHz	
$f_{DCO(2,0)}$	DCO frequency (2, 0)	DCORSELx = 2, DCOx = 0, MODx = 0	0.32	0.75	MHz	
$f_{DCO(2,31)}$	DCO frequency (2, 31)	DCORSELx = 2, DCOx = 31, MODx = 0	3.17	7.38	MHz	
$f_{DCO(3,0)}$	DCO frequency (3, 0)	DCORSELx = 3, DCOx = 0, MODx = 0	0.64	1.51	MHz	
$f_{DCO(3,31)}$	DCO frequency (3, 31)	DCORSELx = 3, DCOx = 31, MODx = 0	6.07	14.0	MHz	
$f_{DCO(4,0)}$	DCO frequency (4, 0)	DCORSELx = 4, DCOx = 0, MODx = 0	1.3	3.2	MHz	
$f_{DCO(4,31)}$	DCO frequency (4, 31)	DCORSELx = 4, DCOx = 31, MODx = 0	12.3	28.2	MHz	
$f_{DCO(5,0)}$	DCO frequency (5, 0)	DCORSELx = 5, DCOx = 0, MODx = 0	2.5	6.0	MHz	
$f_{DCO(5,31)}$	DCO frequency (5, 31)	DCORSELx = 5, DCOx = 31, MODx = 0	23.7	54.1	MHz	
$f_{DCO(6,0)}$	DCO frequency (6, 0)	DCORSELx = 6, DCOx = 0, MODx = 0	4.6	10.7	MHz	
$f_{DCO(6,31)}$	DCO frequency (6, 31)	DCORSELx = 6, DCOx = 31, MODx = 0	39.0	88.0	MHz	
$f_{DCO(7,0)}$	DCO frequency (7, 0)	DCORSELx = 7, DCOx = 0, MODx = 0	8.5	19.6	MHz	
$f_{DCO(7,31)}$	DCO frequency (7, 31)	DCORSELx = 7, DCOx = 31, MODx = 0	60	135	MHz	
$S_{DCORSEL}$	Frequency step between range DCORSEL and DCORSEL + 1	$S_{RSEL} = f_{DCO(DCORSEL+1,DCO)} / f_{DCO(DCORSEL,DCO)}$	1.2	2.3	ratio	
S_{DCO}	Frequency step between tap DCO and DCO + 1	$S_{DCO} = f_{DCO(DCORSEL,DCO+1)} / f_{DCO(DCORSEL,DCO)}$	1.02	1.12	ratio	
Duty cycle		Measured at SMCLK	40	50	60	%
df_{DCO}/dT	DCO frequency temperature drift	$f_{DCO} = 1$ MHz,		0.1		%/°C
df_{DCO}/dV_{CC}	DCO frequency voltage drift	$f_{DCO} = 1$ MHz		1.9		%/V

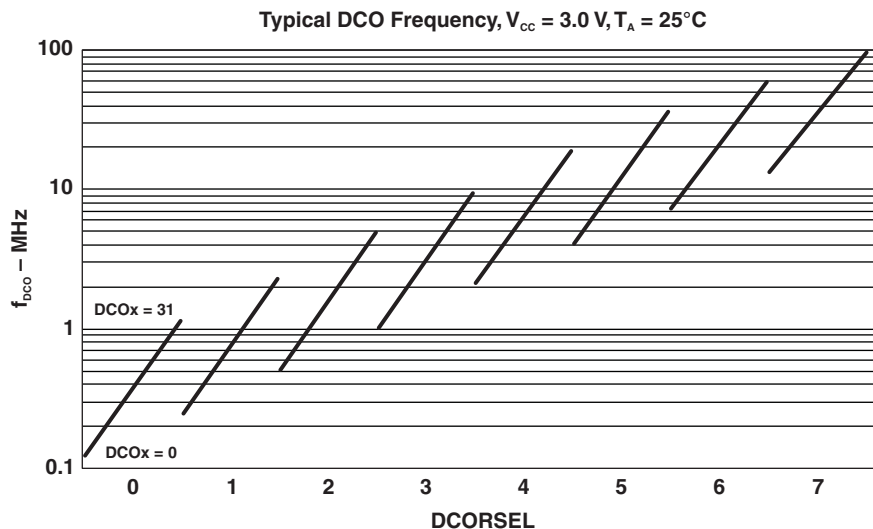

Figure 10. Typical DCO frequency

PMM, Brown-Out Reset (BOR)

over recommended ranges of supply voltage and operating free-air temperature (unless otherwise noted)

PARAMETER		TEST CONDITIONS	MIN	TYP	MAX	UNIT
V(DV _{CC} _BOR_IT-)	BOR _H on voltage, DV _{CC} falling level	dDV _{CC} /dt < 3 V/s			1.45	V
V(DV _{CC} _BOR_IT+)	BOR _H off voltage, DV _{CC} rising level	dDV _{CC} /dt < 3 V/s	0.80	1.30	1.50	V
V(DV _{CC} _BOR_hys)	BOR _H hysteresis		60		250	mV
t _{RESET}	Pulse length required at RST/NMI pin to accept a reset		2			µs

PMM, Core Voltage

over recommended ranges of supply voltage and operating free-air temperature (unless otherwise noted)

PARAMETER		TEST CONDITIONS	MIN	TYP	MAX	UNIT
V _{CORE3} (AM)	Core voltage, active mode, PMMCOREV = 3	2.4 V ≤ DV _{CC} ≤ 3.6 V, 0 mA ≤ I(V _{CORE}) ≤ 21 mA		1.90		V
V _{CORE2} (AM)	Core voltage, active mode, PMMCOREV = 2	2.2 V ≤ DV _{CC} ≤ 3.6 V, 0 mA ≤ I(V _{CORE}) ≤ 21 mA		1.80		V
V _{CORE1} (AM)	Core voltage, active mode, PMMCOREV = 1	2 V ≤ DV _{CC} ≤ 3.6 V, 0 mA ≤ I(V _{CORE}) ≤ 17 mA		1.60		V
V _{CORE0} (AM)	Core voltage, active mode, PMMCOREV = 0	1.8 V ≤ DV _{CC} ≤ 3.6 V, 0 mA ≤ I(V _{CORE}) ≤ 13 mA		1.40		V
V _{CORE3} (LPM)	Core voltage, low-current mode, PMMCOREV = 3	2.4 V ≤ DV _{CC} ≤ 3.6 V, 0 µA ≤ I(V _{CORE}) ≤ 30 µA		1.94		V
V _{CORE2} (LPM)	Core voltage, low-current mode, PMMCOREV = 2	2.2 V ≤ DV _{CC} ≤ 3.6 V, 0 µA ≤ I(V _{CORE}) ≤ 30 µA		1.84		V
V _{CORE1} (LPM)	Core voltage, low-current mode, PMMCOREV = 1	2 V ≤ DV _{CC} ≤ 3.6 V, 0 µA ≤ I(V _{CORE}) ≤ 30 µA		1.64		V
V _{CORE0} (LPM)	Core voltage, low-current mode, PMMCOREV = 0	1.8 V ≤ DV _{CC} ≤ 3.6 V, 0 µA ≤ I(V _{CORE}) ≤ 30 µA		1.44		V

PMM, SVS High Side

over recommended ranges of supply voltage and operating free-air temperature (unless otherwise noted)

PARAMETER		TEST CONDITIONS	MIN	TYP	MAX	UNIT
I _(SVSH)	SVS current consumption	SVSHE = 0, DV _{CC} = 3.6 V		0		nA
		SVSHE = 1, DV _{CC} = 3.6 V, SVSHFP = 0		200		nA
		SVSHE = 1, DV _{CC} = 3.6 V, SVSHFP = 1		2.0		µA
V _(SVSH_IT-)	SVS _H on voltage level ⁽¹⁾	SVSHE = 1, SVSHRVL = 0	1.59	1.64	1.69	V
		SVSHE = 1, SVSHRVL = 1	1.79	1.84	1.91	
		SVSHE = 1, SVSHRVL = 2	1.98	2.04	2.11	
		SVSHE = 1, SVSHRVL = 3	2.10	2.16	2.23	
V _(SVSH_IT+)	SVS _H off voltage level ⁽¹⁾	SVSHE = 1, SVSMHRRL = 0	1.62	1.74	1.81	V
		SVSHE = 1, SVSMHRRL = 1	1.88	1.94	2.01	
		SVSHE = 1, SVSMHRRL = 2	2.07	2.14	2.21	
		SVSHE = 1, SVSMHRRL = 3	2.20	2.26	2.33	
		SVSHE = 1, SVSMHRRL = 4	2.32	2.40	2.48	
		SVSHE = 1, SVSMHRRL = 5	2.56	2.70	2.84	
		SVSHE = 1, SVSMHRRL = 6	2.85	3.00	3.15	
		SVSHE = 1, SVSMHRRL = 7	2.85	3.00	3.15	

(1) The SVS_H settings available depend on the V_{CORE} (PMMCOREVx) setting. See the *Power Management Module and Supply Voltage Supervisor* chapter in the *MSP430F5xx/MSP430F6xx Family User's Guide (SLAU208)* on recommended settings and usage.

PMM, SVS High Side (continued)

over recommended ranges of supply voltage and operating free-air temperature (unless otherwise noted)

PARAMETER		TEST CONDITIONS	MIN	TYP	MAX	UNIT
$t_{pd(SVSH)}$	SVS _H propagation delay	SVSHE = 1, $dV_{DVCC}/dt = 10 \text{ mV}/\mu\text{s}$, SVSHFP = 1		2.5		μs
		SVSHE = 1, $dV_{DVCC}/dt = 1 \text{ mV}/\mu\text{s}$, SVSHFP = 0		20		
$t_{(SVSH)}$	SVS _H on/off delay time	SVSHE = 0→1, SVSHFP = 1		12.5		μs
		SVSHE = 0→1, SVSHFP = 0		100		
dV_{DVCC}/dt	DV _{CC} rise time		0		1000	V/s

PMM, SVM High Side

over recommended ranges of supply voltage and operating free-air temperature (unless otherwise noted)

PARAMETER		TEST CONDITIONS	MIN	TYP	MAX	UNIT
$I_{(SVMH)}$	SVM _H current consumption	SVMHE = 0, DV _{CC} = 3.6 V		0		nA
		SVMHE = 1, DV _{CC} = 3.6 V, SVMHFP = 0		200		nA
		SVMHE = 1, DV _{CC} = 3.6 V, SVMHFP = 1		2.0		μA
$V_{(SVMH)}$	SVM _H on/off voltage level ⁽¹⁾	SVMHE = 1, SVSMHRRL = 0	1.65	1.74	1.86	V
		SVMHE = 1, SVSMHRRL = 1	1.85	1.94	2.02	
		SVMHE = 1, SVSMHRRL = 2	2.02	2.14	2.22	
		SVMHE = 1, SVSMHRRL = 3	2.18	2.26	2.35	
		SVMHE = 1, SVSMHRRL = 4	2.32	2.40	2.48	
		SVMHE = 1, SVSMHRRL = 5	2.56	2.70	2.84	
		SVMHE = 1, SVSMHRRL = 6	2.85	3.00	3.15	
		SVMHE = 1, SVSMHRRL = 7	2.85	3.00	3.15	
$t_{pd(SVMH)}$	SVM _H propagation delay	SVMHE = 1, $dV_{DVCC}/dt = 10 \text{ mV}/\mu\text{s}$, SVMHFP = 1		2.5		μs
		SVMHE = 1, $dV_{DVCC}/dt = 1 \text{ mV}/\mu\text{s}$, SVMHFP = 0		20		μs
$t_{(SVMH)}$	SVM _H on/off delay time	SVMHE = 0→1, SVSMFP = 1		12.5		μs
		SVMHE = 0→1, SVMHFP = 0		100		μs

(1) The SVM_H settings available depend on the VCore (PMMCOREVx) setting. See the *Power Management Module and Supply Voltage Supervisor* chapter in the *MSP430F5xx/MSP430F6xx Family User's Guide (SLAU208)* on recommended settings and usage.

PMM, SVS Low Side

over recommended ranges of supply voltage and operating free-air temperature (unless otherwise noted)

PARAMETER		TEST CONDITIONS	MIN	TYP	MAX	UNIT
$I_{(SVSL)}$	SVS _L current consumption	SVSLE = 0, PMMCOREV = 2		0		nA
		SVSLE = 1, PMMCOREV = 2, SVSLFP = 0		200		nA
		SVSLE = 1, PMMCOREV = 2, SVSLFP = 1		2.0		μA
$t_{pd(SVSL)}$	SVS _L propagation delay	SVSLE = 1, $dV_{CORE}/dt = 10 \text{ mV}/\mu\text{s}$, SVSLFP = 1		2.5		μs
		SVSLE = 1, $dV_{CORE}/dt = 1 \text{ mV}/\mu\text{s}$, SVSLFP = 0		20		
$t_{(SVSL)}$	SVS _L on/off delay time	SVSLE = 0→1, SVSLFP = 1		12.5		μs
		SVSLE = 0→1, SVSLFP = 0		100		

PMM, SVM Low Side

over recommended ranges of supply voltage and operating free-air temperature (unless otherwise noted)

PARAMETER		TEST CONDITIONS	MIN	TYP	MAX	UNIT
$I_{(SVM_L)}$	SVM _L current consumption	SVMLE = 0, PMMCOREV = 2		0		nA
		SVMLE = 1, PMMCOREV = 2, SVMLFP = 0		200		nA
		SVMLE = 1, PMMCOREV = 2, SVMLFP = 1		2.0		μA
$t_{pd(SVM_L)}$	SVM _L propagation delay	SVMLE = 1, $dV_{CORE}/dt = 10 \text{ mV}/\mu\text{s}$, SVMLFP = 1		2.5		μs
		SVMLE = 1, $dV_{CORE}/dt = 1 \text{ mV}/\mu\text{s}$, SVMLFP = 0		20		
$t_{(SVM_L)}$	SVM _L on/off delay time	SVMLE = 0→1, SVMLFP = 1		12.5		μs
		SVMLE = 0→1, SVMLFP = 0		100		

Wake-Up From Low-Power Modes and Reset

over recommended ranges of supply voltage and operating free-air temperature (unless otherwise noted)

PARAMETER		TEST CONDITIONS	MIN	TYP	MAX	UNIT
$t_{\text{WAKE-UP-FAST}}$	Wake-up time from LPM2, LPM3, or LPM4 to active mode ⁽¹⁾	PMMCOREV = SVSMLRRL = n (where n = 0, 1, 2, or 3), SVSLFP = 1	$f_{\text{MCLK}} \geq 4 \text{ MHz}$ $1 \text{ MHz} < f_{\text{MCLK}} < 4 \text{ MHz}$	3	6.5	μs
				4	8.0	
$t_{\text{WAKE-UP-SLOW}}$	Wake-up time from LPM2, LPM3 or LPM4 to active mode ⁽²⁾	PMMCOREV = SVSMLRRL = n (where n = 0, 1, 2, or 3), SVSLFP = 0		150	165	μs
$t_{\text{WAKE-UP-LPM5}}$	Wake-up time from LPM3.5 or LPM4.5 to active mode ⁽³⁾			2	3	ms
$t_{\text{WAKE-UP-RESET}}$	Wake-up time from $\overline{\text{RST}}$ or BOR event to active mode ⁽³⁾			2	3	ms

- (1) This value represents the time from the wakeup event to the first active edge of MCLK. The wakeup time depends on the performance mode of the low side supervisor (SVSL) and low side monitor (SVM_L). Fastest wakeup times are possible with SVSL and SVM_L in full performance mode or disabled when operating in AM, LPM0, and LPM1. Various options are available for SVSL and SVM_L while operating in LPM2, LPM3, and LPM4. See the *Power Management Module and Supply Voltage Supervisor* chapter in the *MSP430x5xx Family User's Guide (SLAU208)*.
- (2) This value represents the time from the wakeup event to the first active edge of MCLK. The wakeup time depends on the performance mode of the low side supervisor (SVSL) and low side monitor (SVM_L). In this case, the SVSL and SVM_L are in normal mode (low current) mode when operating in AM, LPM0, and LPM1. Various options are available for SVSL and SVM_L while operating in LPM2, LPM3, and LPM4. See the *Power Management Module and Supply Voltage Supervisor* chapter in the *MSP430x5xx Family User's Guide (SLAU208)*.
- (3) This value represents the time from the wakeup event to the reset vector execution.

Timer_A, Timers TA0, TA1, and TA2

over recommended ranges of supply voltage and operating free-air temperature (unless otherwise noted)

PARAMETER		TEST CONDITIONS	V _{CC}	MIN	TYP	MAX	UNIT
f_{TA}	Timer_A input clock frequency	Internal: SMCLK, ACLK External: TACLK Duty cycle = 50% ± 10%	1.8 V / 3 V			20	MHz
$t_{TA,cap}$	Timer_A capture timing	All capture inputs. Minimum pulse width required for capture.	1.8 V / 3 V	20			ns

Timer_B, Timer TB0

over recommended ranges of supply voltage and operating free-air temperature (unless otherwise noted)

PARAMETER		TEST CONDITIONS	V _{CC}	MIN	TYP	MAX	UNIT
f_{TB}	Timer_B input clock frequency	Internal: SMCLK, ACLK External: TBCLK Duty cycle = 50% ± 10%	1.8 V / 3 V			20	MHz

Timer_B, Timer TB0 (continued)

over recommended ranges of supply voltage and operating free-air temperature (unless otherwise noted)

PARAMETER		TEST CONDITIONS	V _{CC}	MIN	TYP	MAX	UNIT
t _{TB,cap}	Timer_B capture timing	All capture inputs. Minimum pulse width required for capture.	1.8 V/ 3 V	20			ns

Battery Backup

over operating free-air temperature range (unless otherwise noted)

PARAMETER		TEST CONDITIONS	V _{CC}	MIN	TYP	MAX	UNIT	
I _{VBAT}	Current into VBAT terminal in case no primary battery is connected.	VBAT = 1.7 V, DVCC not connected, RTC running	0 V		T _A = -40°C	0.43	μA	
					T _A = 25°C	0.52		
					T _A = 60°C	0.58		
					T _A = 85°C	0.64		
		VBAT = 2.2 V, DVCC not connected, RTC running		T _A = -40°C	0.50	μA		
				T _A = 25°C	0.59			
				T _A = 60°C	0.64			
				T _A = 85°C	0.71			
		VBAT = 3 V, DVCC not connected, RTC running		T _A = -40°C	0.68	μA		
				T _A = 25°C	0.75			
				T _A = 60°C	0.79			
				T _A = 85°C	0.86			
V _{SWITCH}	Switch-over level (V _{CC} to VBAT)	C _{VCC} = 4.7 μF	0 V		General	V _{SVSH_IT-}		V
					SVSHRL = 0	1.59	1.69	
					SVSHRL = 1	1.79	1.91	
					SVSHRL = 2	1.98	2.11	
					SVSHRL = 3	2.10	2.23	
R _{ON_VBAT}	On-resistance of switch between VBAT and VBAK	V _{BAT} = 1.8 V	0 V		0.35	1	kΩ	
V _{BAT3}	VBAT to ADC: V _{BAT} divide, V _{BAT3} ≠ V _{BAT} /3				1.8 V	0.6	±5%	V
					3 V	1.0	±5%	
					3.6 V	1.2	±5%	
t _{Sample,VBA T3}	VBAT to ADC: Sampling time required if VBAT3 selected	ADC12ON = 1, Error of conversion result ≤ 1 LSB			1000		ns	
V _{CHVx}	Charger end voltage	CHVx = 2			2.65	2.7	2.9	V
R _{CHARGE}	Charge limiting resistor				CHCx = 1		5	kΩ
					CHCx = 2		10	
					CHCx = 3		20	

USCI (UART Mode)

over recommended ranges of supply voltage and operating free-air temperature (unless otherwise noted)

PARAMETER		TEST CONDITIONS	V _{CC}	MIN	TYP	MAX	UNIT
f _{USCI}	USCI input clock frequency	Internal: SMCLK, ACLK External: UCLK Duty cycle = 50% ± 10%				f _{SYSTEM}	MHz
f _{BITCLK}	BITCLK clock frequency (equals baud rate in MBaud)					1	MHz
t _r	UART receive deglitch time ⁽¹⁾		2.2 V	50		600	ns
			3 V	50		600	

(1) Pulses on the UART receive input (UCxRX) shorter than the UART receive deglitch time are suppressed. To ensure that pulses are correctly recognized their width should exceed the maximum specification of the deglitch time.

USCI (SPI Master Mode)

over recommended ranges of supply voltage and operating free-air temperature (unless otherwise noted)
(see Note ⁽¹⁾, Figure 11 and)

PARAMETER		TEST CONDITIONS	V _{CC}	MIN	TYP	MAX	UNIT
f _{USCI}	USCI input clock frequency	SMCLK, ACLK, Duty cycle = 50% ± 10%				f _{SYSTEM}	MHz
t _{SU,MI}	SOMI input data setup time	PMMCOREV = 0	1.8 V	55			ns
			3 V	38			
		PMMCOREV = 3	2.4 V	30		ns	
			3 V	25			
t _{HD,MI}	SOMI input data hold time	PMMCOREV = 0	1.8 V	0			ns
			3 V	0			
		PMMCOREV = 3	2.4 V	0		ns	
			3 V	0			
t _{VALID,MO}	SIMO output data valid time ⁽²⁾	UCLK edge to SIMO valid, C _L = 20 pF, PMMCOREV = 0	1.8 V			20	ns
			3 V			18	
		UCLK edge to SIMO valid, C _L = 20 pF, PMMCOREV = 3	2.4 V			16	ns
			3 V			15	
t _{HD,MO}	SIMO output data hold time ⁽³⁾	C _L = 20 pF, PMMCOREV = 0	1.8 V	-10			ns
			3 V	-8			
		C _L = 20 pF, PMMCOREV = 3	2.4 V	-10		ns	
			3 V	-8			

- (1) $f_{UCxCLK} = 1/2t_{LO/HI}$ with $t_{LO/HI} \geq \max(t_{VALID,MO}(USCI) + t_{SU,SI}(Slave), t_{SU,MI}(USCI) + t_{VALID,SO}(Slave))$.
For the slave's parameters $t_{SU,SI}(Slave)$ and $t_{VALID,SO}(Slave)$, see the SPI parameters of the attached slave.
- (2) Specifies the time to drive the next valid data to the SIMO output after the output changing UCLK clock edge. Refer to the timing diagrams in Figure 11 and .
- (3) Specifies how long data on the SIMO output is valid after the output changing UCLK clock edge. Negative values indicate that the data on the SIMO output can become invalid before the output changing clock edge observed on UCLK. Refer to the timing diagrams in Figure 11 and .

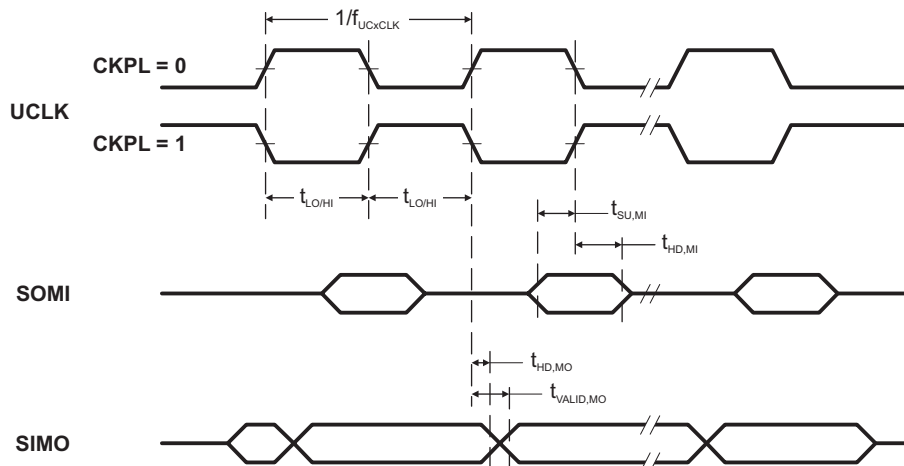

Figure 11. SPI Master Mode, CKPH = 0

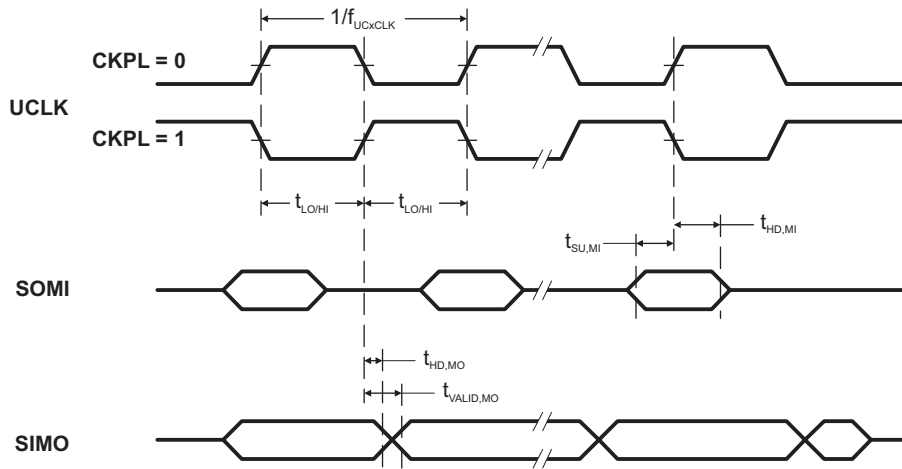

Figure 12. SPI Master Mode, CKPH = 1

USCI (SPI Slave Mode)

over recommended ranges of supply voltage and operating free-air temperature (unless otherwise noted)
(see Note ⁽¹⁾, [Figure 13](#) and [Figure 14](#))

PARAMETER		TEST CONDITIONS	V _{CC}	MIN	TYP	MAX	UNIT
t _{STE,LEAD}	STE lead time, STE low to clock	PMMCOREV = 0	1.8 V	11			ns
			3 V	8			
		PMMCOREV = 3	2.4 V	7			ns
			3 V	6			
t _{STE,LAG}	STE lag time, Last clock to STE high	PMMCOREV = 0	1.8 V	3			ns
			3 V	3			
		PMMCOREV = 3	2.4 V	3			ns
			3 V	3			
t _{STE,ACC}	STE access time, STE low to SOMI data out	PMMCOREV = 0	1.8 V			66	ns
			3 V			50	
		PMMCOREV = 3	2.4 V			36	ns
			3 V			30	
t _{STE,DIS}	STE disable time, STE high to SOMI high impedance	PMMCOREV = 0	1.8 V			30	ns
			3 V			23	
		PMMCOREV = 3	2.4 V			16	ns
			3 V			13	
t _{SU,SI}	SIMO input data setup time	PMMCOREV = 0	1.8 V	5			ns
			3 V	5			
		PMMCOREV = 3	2.4 V	2			ns
			3 V	2			
t _{HD,SI}	SIMO input data hold time	PMMCOREV = 0	1.8 V	5			ns
			3 V	5			
		PMMCOREV = 3	2.4 V	5			ns
			3 V	5			
t _{VALID,SO}	SOMI output data valid time ⁽²⁾	UCLK edge to SOMI valid, C _L = 20 pF, PMMCOREV = 0	1.8 V			76	ns
			3 V			60	
		UCLK edge to SOMI valid, C _L = 20 pF, PMMCOREV = 3	2.4 V			44	ns
			3 V			40	
t _{HD,SO}	SOMI output data hold time ⁽³⁾	C _L = 20 pF, PMMCOREV = 0	1.8 V	18			ns
			3 V	12			
		C _L = 20 pF, PMMCOREV = 3	2.4 V	10			ns
			3 V	8			

- (1) $f_{UCXCLK} = 1/2t_{LO/HI}$ with $t_{LO/HI} \geq \max(t_{VALID,MO(Master)} + t_{SU,SI(USCI)}, t_{SU,MI(Master)} + t_{VALID,SO(USCI)})$.
For the master's parameters $t_{SU,MI(Master)}$ and $t_{VALID,MO(Master)}$, see the SPI parameters of the attached slave.
- (2) Specifies the time to drive the next valid data to the SOMI output after the output changing UCLK clock edge. Refer to the timing diagrams in [Figure 13](#) and [Figure 14](#).
- (3) Specifies how long data on the SOMI output is valid after the output changing UCLK clock edge. Refer to the timing diagrams in [Figure 13](#) and [Figure 14](#).

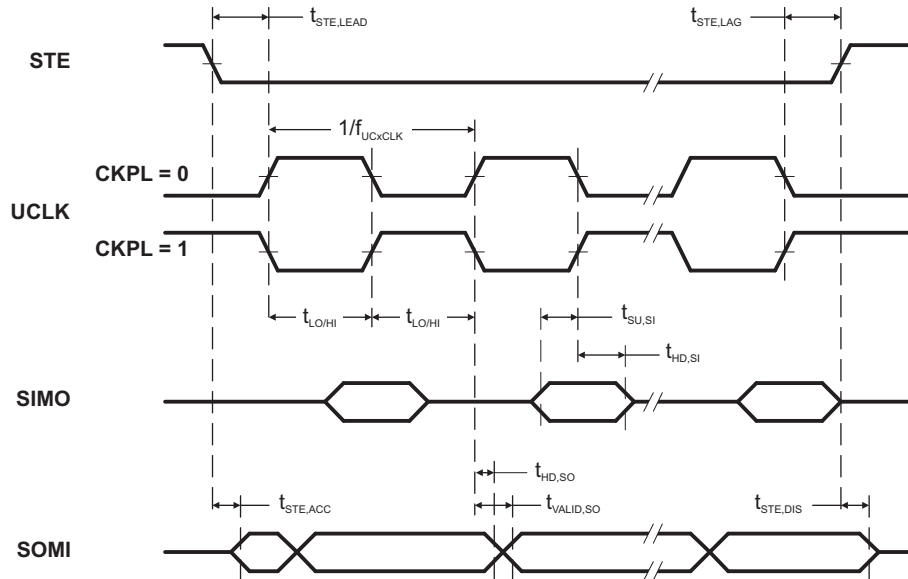

Figure 13. SPI Slave Mode, CKPH = 0

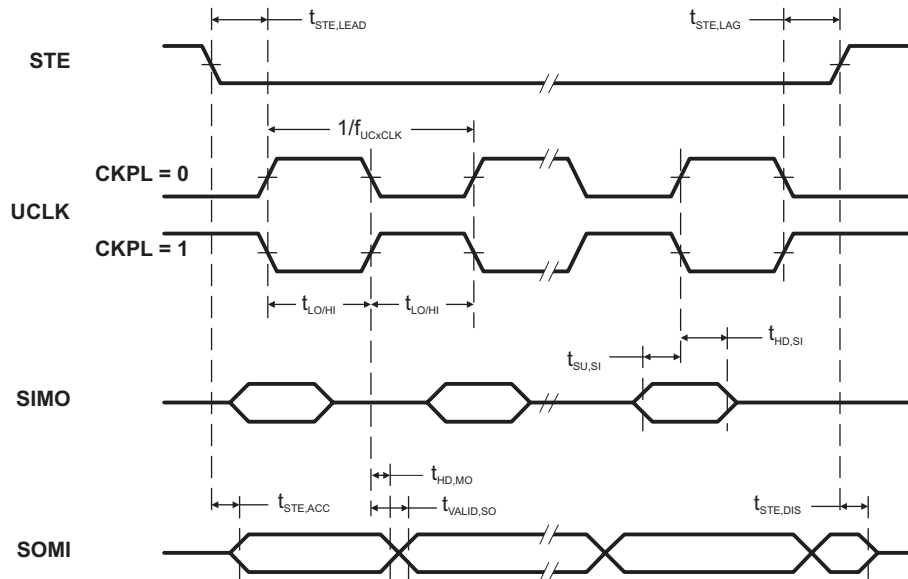

Figure 14. SPI Slave Mode, CKPH = 1

USCI (I2C Mode)

over recommended ranges of supply voltage and operating free-air temperature (unless otherwise noted) (see [Figure 15](#))

PARAMETER	TEST CONDITIONS	V _{CC}	MIN	TYP	MAX	UNIT
f _{USCI}	USCI input clock frequency				f _{SYSTEM}	MHz
f _{SCL}	SCL clock frequency	2.2 V/3 V	0		400	kHz
t _{HD,STA}	Hold time (repeated) START	f _{SCL} ≤ 100 kHz f _{SCL} > 100 kHz	4.0			μs
t _{SU,STA}	Setup time for a repeated START	f _{SCL} ≤ 100 kHz f _{SCL} > 100 kHz	4.7			μs
t _{HD,DAT}	Data hold time	2.2 V/3 V	0			ns
t _{SU,DAT}	Data setup time	2.2 V/3 V	250			ns
t _{SU,STO}	Setup time for STOP	f _{SCL} ≤ 100 kHz f _{SCL} > 100 kHz	4.0			μs
t _{SP}	Pulse width of spikes suppressed by input filter	2.2 V 3 V	50		600	ns

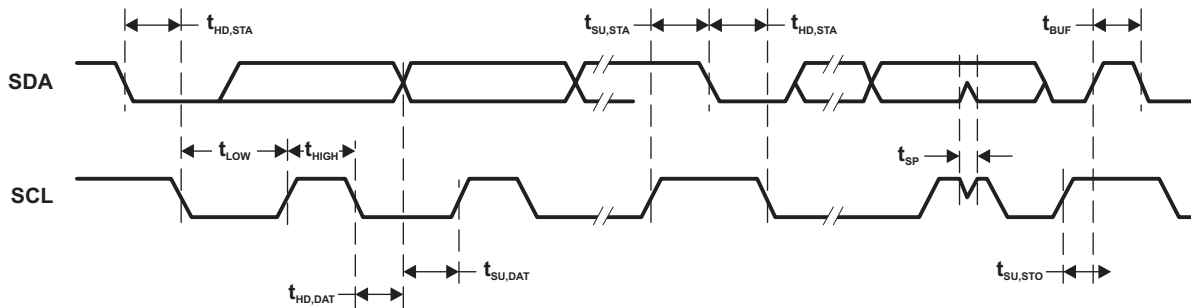

Figure 15. I2C Mode Timing

LCD_B, Recommended Operating Conditions

PARAMETER		CONDITIONS	MIN	NOM	MAX	UNIT
$V_{CC,LCD_B, CP\ en,3.6}$	Supply voltage range, charge pump enabled, $V_{LCD} \leq 3.6\text{ V}$	LCDCPEN = 1, $0000 < VLCDx \leq 1111$ (charge pump enabled, $V_{LCD} \leq 3.6\text{ V}$)	2.2		3.6	V
$V_{CC,LCD_B, CP\ en,3.3}$	Supply voltage range, charge pump enabled, $V_{LCD} \leq 3.3\text{ V}$	LCDCPEN = 1, $0000 < VLCDx \leq 1100$ (charge pump enabled, $V_{LCD} \leq 3.3\text{ V}$)	2.0		3.6	V
$V_{CC,LCD_B, int. bias}$	Supply voltage range, internal biasing, charge pump disabled	LCDCPEN = 0, VLCDEXT = 0	2.4		3.6	V
$V_{CC,LCD_B, ext. bias}$	Supply voltage range, external biasing, charge pump disabled	LCDCPEN = 0, VLCDEXT = 0	2.4		3.6	V
$V_{CC,LCD_B, VLCDEXT}$	Supply voltage range, external LCD voltage, internal or external biasing, charge pump disabled	LCDCPEN = 0, VLCDEXT = 1	2.0		3.6	V
$V_{LCDCAP/R33}$	External LCD voltage at LCDCAP/R33, internal or external biasing, charge pump disabled	LCDCPEN = 0, VLCDEXT = 1	2.4		3.6	V
C_{LDCAP}	Capacitor on LCDCAP when charge pump enabled	LCDCPEN = 1, $VLCDx > 0000$ (charge pump enabled)	4.7	4.7	10	μF
f_{Frame}	LCD frame frequency range	$f_{LCD} = 2 \times MUX \times f_{FRAME}$ (mux = 1 (static), 2, 3, 4)	0		100	Hz
$f_{ACLK,in}$	ACLK input frequency range		30	32	40	kHz
C_{Panel}	Panel capacitance	100-Hz frame frequency			10000	pF
V_{R33}	Analog input voltage at R33	LCDCPEN = 0, VLCDEXT = 1	2.4		$V_{CC} + 0.2$	V
$V_{R23,1/3bias}$	Analog input voltage at R23	LCDREXT = 1, LCDEXTBIAS = 1, LCD2B = 0	V_{R13}	$V_{R03} + \frac{2}{3} \times (V_{R33} - V_{R03})$	V_{R33}	V
$V_{R13,1/3bias}$	Analog input voltage at R13 with 1/3 biasing	LCDREXT = 1, LCDEXTBIAS = 1, LCD2B = 0	V_{R03}	$V_{R03} + \frac{1}{3} \times (V_{R33} - V_{R03})$	V_{R23}	V
$V_{R13,1/2bias}$	Analog input voltage at R13 with 1/2 biasing	LCDREXT = 1, LCDEXTBIAS = 1, LCD2B = 1	V_{R03}	$V_{R03} + \frac{1}{2} \times (V_{R33} - V_{R03})$	V_{R33}	V
V_{R03}	Analog input voltage at R03	R0EXT = 1	V_{SS}			V
$V_{LCD} - V_{R03}$	Voltage difference between V_{LCD} and R03	LCDCPEN = 0, R0EXT = 1	2.4		$V_{CC} + 0.2$	V
$V_{LCDREF/R13}$	External LCD reference voltage applied at LCDREF/R13	VLCDREFx = 01	0.8	1.2	1.5	V

LCD_B, Electrical Characteristics

over operating free-air temperature range (unless otherwise noted)

PARAMETER		TEST CONDITIONS	V _{CC}	MIN	TYP	MAX	UNIT
V _{LCD}	LCD voltage	VLCDx = 0000, VLCDxEXT = 0	2.4 V - 3.6 V		V _{CC}		V
		LCDCPEN = 1, VLCDx = 0001	2 V - 3.6 V		2.60		V
		LCDCPEN = 1, VLCDx = 0010	2 V - 3.6 V		2.66		V
		LCDCPEN = 1, VLCDx = 0011	2 V - 3.6 V		2.72		V
		LCDCPEN = 1, VLCDx = 0100	2 V - 3.6 V		2.79		V
		LCDCPEN = 1, VLCDx = 0101	2 V - 3.6 V		2.85		V
		LCDCPEN = 1, VLCDx = 0110	2 V - 3.6 V		2.92		V
		LCDCPEN = 1, VLCDx = 0111	2 V - 3.6 V		2.98		V
		LCDCPEN = 1, VLCDx = 1000	2 V - 3.6 V		3.05		V
		LCDCPEN = 1, VLCDx = 1001	2 V - 3.6 V		3.10		V
		LCDCPEN = 1, VLCDx = 1010	2 V - 3.6 V		3.17		V
		LCDCPEN = 1, VLCDx = 1011	2 V - 3.6 V		3.24		V
		LCDCPEN = 1, VLCDx = 1100	2 V - 3.6 V		3.30		V
		LCDCPEN = 1, VLCDx = 1101	2.2 V - 3.6 V		3.36		V
LCDCPEN = 1, VLCDx = 1110	2.2 V - 3.6 V		3.42		V		
LCDCPEN = 1, VLCDx = 1111	2.2 V - 3.6 V		3.48	3.6	V		
I _{CC,Peak,CP}	Peak supply currents due to charge pump activities	LCDCPEN = 1, VLCDx = 1111	2.2 V		400		μA
t _{LCD,CP,on}	Time to charge C _{LCD} when discharged	C _{LCD} = 4.7μF, LCDCPEN = 0→1, VLCDx = 1111	2.2 V		100	500	ms
I _{CP,Load}	Maximum charge pump load current	LCDCPEN = 1, VLCDx = 1111	2.2 V	50			μA
R _{LCD,Seg}	LCD driver output impedance, segment lines	LCDCPEN = 1, VLCDx = 1000, I _{LOAD} = ±10μA	2.2 V			10	kΩ
R _{LCD,COM}	LCD driver output impedance, common lines	LCDCPEN = 1, VLCDx = 1000, I _{LOAD} = ±10μA	2.2 V			10	kΩ

12-Bit ADC, Power Supply and Input Range Conditions

 over recommended ranges of supply voltage and operating free-air temperature (unless otherwise noted)⁽¹⁾

PARAMETER		TEST CONDITIONS	V _{CC}	MIN	TYP	MAX	UNIT
AV _{CC}	Analog supply voltage	AVCC and DVCC are connected together, AVSS and DVSS are connected together, V(AVSS) = V(DVSS) = 0 V		2.2		3.6	V
V _(Ax)	Analog input voltage range ⁽²⁾	All ADC12 analog input pins Ax		0		AV _{CC}	V
I _{ADC12_A}	Operating supply current into AV _{CC} terminal ⁽³⁾	f _{ADC12CLK} = 5.0 MHz ⁽⁴⁾	2.2 V		150	200	μA
			3 V		150	250	
C _I	Input capacitance	Only one terminal Ax can be selected at one time	2.2 V		20	25	pF
R _I	Input MUX ON resistance	0 V ≤ VIN ≤ V(AVCC)		10	200	1900	Ω

- (1) The leakage current is specified by the digital I/O input leakage.
- (2) The analog input voltage range must be within the selected reference voltage range V_{R+} to V_{R-} for valid conversion results. If the reference voltage is supplied by an external source or if the internal voltage is used and REFOUT = 1, then decoupling capacitors are required. See [REF, External Reference](#) and [REF, Built-In Reference](#).
- (3) The internal reference supply current is not included in current consumption parameter I_{ADC12}.
- (4) ADC12ON = 1, REFON = 0, SHT0 = 0, SHT1 = 0, ADC12DIV = 0

12-Bit ADC, Timing Parameters

over recommended ranges of supply voltage and operating free-air temperature (unless otherwise noted)

PARAMETER	TEST CONDITIONS	V _{CC}	MIN	TYP	MAX	UNIT
f _{ADC12CLK} ADC conversion clock	For specified performance of ADC12 linearity parameters using an external reference voltage or AVCC as reference ⁽¹⁾	2.2 V/3 V	0.45	4.8	5.0	MHz
	For specified performance of ADC12 linearity parameters using the internal reference ⁽²⁾		0.45	2.4	4.0	
	For specified performance of ADC12 linearity parameters using the internal reference ⁽³⁾		0.45	2.4	2.7	
f _{ADC12OSC} Internal ADC12 oscillator ⁽⁴⁾	ADC12DIV = 0, f _{ADC12CLK} = f _{ADC12OSC}	2.2 V/3 V	4.2	4.8	5.4	MHz
t _{CONVERT} Conversion time	REFON = 0, Internal oscillator, ADC12OSC used for ADC conversion clock	2.2 V/3 V	2.4		3.1	μs
	External f _{ADC12CLK} from ACLK, MCLK or SMCLK, ADC12SSEL ≠ 0			(5)		
t _{Sample} Sampling time	R _S = 400 Ω, R _I = 200 Ω, C _I = 20 pF, T = [R _S + R _I] × C _I ⁽⁶⁾	2.2 V/3 V	1000			ns

- (1) REFOUT = 0, external reference voltage: SREF2 = 0, SREF1 = 1, SREF0 = 0. AVCC as reference voltage: SREF2 = 0, SREF1 = 0, SREF0 = 0. The specified performance of the ADC12 linearity is ensured when using the ADC12OSC. For other clock sources, the specified performance of the ADC12 linearity is ensured with f_{ADC12CLK} maximum of 5.0 MHz.
- (2) SREF2 = 0, SREF1 = 1, SREF0 = 0, ADC12SR = 0, REFOUT = 1
- (3) SREF2 = 0, SREF1 = 1, SREF0 = 0, ADC12SR = 0, REFOUT = 0. The specified performance of the ADC12 linearity is ensured when using the ADC12OSC divided by 2.
- (4) The ADC12OSC is sourced directly from MODOSC inside the UCS.
- (5) 13 × ADC12DIV × 1/f_{ADC12CLK}
- (6) Approximately ten Tau (τ) are needed to get an error of less than ±0.5 LSB:
 $t_{\text{Sample}} = \ln(2^{n+1}) \times (R_S + R_I) \times C_I + 800 \text{ ns}$, where n = ADC resolution = 12, R_S = external source resistance

12-Bit ADC, Linearity Parameters Using an External Reference Voltage

over recommended ranges of supply voltage and operating free-air temperature (unless otherwise noted)

PARAMETER	TEST CONDITIONS	V _{CC}	MIN	TYP	MAX	UNIT
E _I Integral linearity error ⁽¹⁾	1.4 V ≤ dVREF ≤ 1.6 V ⁽²⁾	2.2 V/3 V			±2	LSB
	1.6 V < dVREF ⁽²⁾				±1.7	
E _D Differential linearity error ⁽¹⁾	⁽²⁾	2.2 V/3 V			±1	LSB
E _O Offset error ⁽³⁾	dVREF ≤ 2.2 V ⁽²⁾	2.2 V/3 V		±3	±5.6	LSB
	dVREF > 2.2 V ⁽²⁾	2.2 V/3 V		±1.5	±3.5	
E _G Gain error ⁽³⁾	⁽²⁾	2.2 V/3 V		±1	±2.5	LSB
E _T Total unadjusted error	dVREF ≤ 2.2 V ⁽²⁾	2.2 V/3 V		±3.5	±7.1	LSB
	dVREF > 2.2 V ⁽²⁾	2.2 V/3 V		±2	±5	

- (1) Parameters are derived using the histogram method.
- (2) The external reference voltage is selected by: SREF2 = 0 or 1, SREF1 = 1, SREF0 = 0. dVREF = V_{R+} - V_{R-}. V_{R+} < AVCC. V_{R-} > AVSS. Unless otherwise mentioned dVREF > 1.5V. Impedance of the external reference voltage R < 100 Ohm and two decoupling capacitors, 10μF and 100nF, should be connected to VREF to decouple the dynamic current. See also the *MSP430F5xx/MSP430F6xx Family User's Guide (SLAU208)*.
- (3) Parameters are derived using a best fit curve.

12-Bit ADC, Linearity Parameters Using AVCC as Reference Voltage

over recommended ranges of supply voltage and operating free-air temperature (unless otherwise noted)

PARAMETER	TEST CONDITIONS	V _{CC}	MIN	TYP	MAX	UNIT
E _I Integral linearity error ⁽¹⁾	See ⁽²⁾	2.2 V/3 V			±1.7	LSB
E _D Differential linearity error ⁽¹⁾	See ⁽²⁾	2.2 V/3 V			±1	LSB
E _O Offset error ⁽³⁾	See ⁽²⁾	2.2 V/3 V		±1	±2	LSB

- (1) Parameters are derived using the histogram method.
- (2) AVCC as reference voltage is selected by: SREF2 = 0, SREF1 = 0, SREF0 = 0.
- (3) Parameters are derived using a best fit curve.

12-Bit ADC, Linearity Parameters Using AVCC as Reference Voltage (continued)

over recommended ranges of supply voltage and operating free-air temperature (unless otherwise noted)

PARAMETER		TEST CONDITIONS	V _{CC}	MIN	TYP	MAX	UNIT
E _G	Gain error ⁽³⁾	See ⁽²⁾	2.2 V/3 V		±2	±4	LSB
E _T	Total unadjusted error	See ⁽²⁾	2.2 V/3 V		±2	±5	LSB

12-Bit ADC, Linearity Parameters Using the Internal Reference Voltage

over recommended ranges of supply voltage and operating free-air temperature (unless otherwise noted)

PARAMETER		TEST CONDITIONS ⁽¹⁾		V _{CC}	MIN	TYP	MAX	UNIT
E _I	Integral linearity error ⁽²⁾	ADC12SR = 0, REFOUT = 1	f _{ADC12CLK} ≤ 4.0 MHz	2.2 V/3 V			±1.7	LSB
		ADC12SR = 0, REFOUT = 0	f _{ADC12CLK} ≤ 2.7 MHz				±2.5	
E _D	Differential linearity error ⁽²⁾	ADC12SR = 0, REFOUT = 1	f _{ADC12CLK} ≤ 4.0 MHz	2.2 V/3 V	-1		+1.5	LSB
		ADC12SR = 0, REFOUT = 1	f _{ADC12CLK} ≤ 2.7 MHz				±1	
		ADC12SR = 0, REFOUT = 0	f _{ADC12CLK} ≤ 2.7 MHz		-1		+2.5	
E _O	Offset error ⁽³⁾	ADC12SR = 0, REFOUT = 1	f _{ADC12CLK} ≤ 4.0 MHz	2.2 V/3 V		±2	±4	LSB
		ADC12SR = 0, REFOUT = 0	f _{ADC12CLK} ≤ 2.7 MHz			±2	±4	
E _G	Gain error ⁽³⁾	ADC12SR = 0, REFOUT = 1	f _{ADC12CLK} ≤ 4.0 MHz	2.2 V/3 V		±1	±2.5	LSB
		ADC12SR = 0, REFOUT = 0	f _{ADC12CLK} ≤ 2.7 MHz				±1% ⁽⁴⁾	VREF
E _T	Total unadjusted error	ADC12SR = 0, REFOUT = 1	f _{ADC12CLK} ≤ 4.0 MHz	2.2 V/3 V		±2	±5	LSB
		ADC12SR = 0, REFOUT = 0	f _{ADC12CLK} ≤ 2.7 MHz				±1% ⁽⁴⁾	VREF

(1) The external reference voltage is selected by: SREF2 = 0, SREF1 = 0, SREF0 = 1. dVREF = V_{R+} - V_{R-}.

(2) Parameters are derived using the histogram method.

(3) Parameters are derived using a best fit curve.

(4) The gain error and the total unadjusted error are dominated by the accuracy of the integrated reference module absolute accuracy. In this mode the reference voltage used by the ADC12_A is not available on a pin.

12-Bit ADC, Temperature Sensor and Built-In V_{MID}⁽¹⁾

over recommended ranges of supply voltage and operating free-air temperature (unless otherwise noted)

PARAMETER		TEST CONDITIONS	V _{CC}	MIN	TYP	MAX	UNIT
V _{SENSOR}	See ⁽²⁾	ADC12ON = 1, INCH = 0Ah, T _A = 0°C	2.2 V		680		mV
			3 V		680		
TC _{SENSOR}		ADC12ON = 1, INCH = 0Ah	2.2 V		2.25		mV/°C
			3 V		2.25		
t _{SENSOR(sample)}	Sample time required if channel 10 is selected ⁽³⁾	ADC12ON = 1, INCH = 0Ah, Error of conversion result ≤ 1 LSB	2.2 V		30		µs
			3 V		30		
V _{MID}	AV _{CC} divider at channel 11	ADC12ON = 1, INCH = 0Bh, V _{MID} is ~0.5 × V _{AVCC}	2.2 V	1.06	1.1	1.14	V
			3 V	1.46	1.5	1.54	
t _{VMID(sample)}	Sample time required if channel 11 is selected ⁽⁴⁾	ADC12ON = 1, INCH = 0Bh, Error of conversion result ≤ 1 LSB	2.2 V/3 V	1000			ns

(1) The temperature sensor is provided by the REF module. Please refer to the REF module parametric, I_{REF+}, regarding the current consumption of the temperature sensor.

(2) The temperature sensor offset can be as much as ±20°C. A single-point calibration is recommended in order to minimize the offset error of the built-in temperature sensor. The TLV structure contains calibration values for 30°C ± 3°C and 85°C ± 3°C for each of the available reference voltage levels. The sensor voltage can be computed as V_{SENSE} = TC_{SENSOR} * (Temperature, °C) + V_{SENSOR}, where TC_{SENSOR} and V_{SENSOR} can be computed from the calibration values for higher accuracy. See also the *MSP430F5xx/MSP430F6xx Family User's Guide (SLAU208)*.

(3) The typical equivalent impedance of the sensor is 51 kΩ. The sample time required includes the sensor-on time t_{SENSOR(on)}.

(4) The on-time t_{VMID(on)} is included in the sampling time t_{VMID(sample)}; no additional on time is needed.

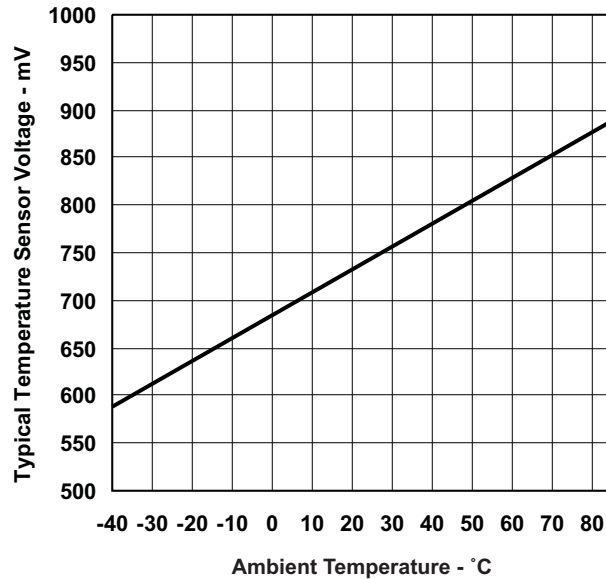

Figure 16. Typical Temperature Sensor Voltage

REF, External Reference

over recommended ranges of supply voltage and operating free-air temperature (unless otherwise noted)⁽¹⁾

PARAMETER		TEST CONDITIONS	V _{CC}	MIN	TYP	MAX	UNIT
V _{eREF+}	Positive external reference voltage input	V _{eREF+} > V _{REF-} /V _{eREF-} ⁽²⁾		1.4		AV _{CC}	V
V _{REF-} /V _{eREF-}	Negative external reference voltage input	V _{eREF+} > V _{REF-} /V _{eREF-} ⁽³⁾		0		1.2	V
V _{eREF+} – V _{REF-} /V _{eREF-}	Differential external reference voltage input	V _{eREF+} > V _{REF-} /V _{eREF-} ⁽⁴⁾		1.4		AV _{CC}	V
I _{VeREF+} , I _{VREF-/VeREF-}	Static input current	1.4 V ≤ V _{eREF+} ≤ V _{AVCC} , V _{eREF-} = 0 V, f _{ADC12CLK} = 5 MHz, ADC12SHTx = 1h, Conversion rate 200 ksp/s	2.2 V/3 V	-26		26	μA
		1.4 V ≤ V _{eREF+} ≤ V _{AVCC} , V _{eREF-} = 0 V, f _{ADC12CLK} = 5 MHz, ADC12SHTx = 8h, Conversion rate 20 ksp/s	2.2 V/3 V	-1.2		+1.2	μA
C _{VREF+/-}	Capacitance at V _{REF+/-} terminal ⁽⁵⁾			10			μF

- (1) The external reference is used during ADC conversion to charge and discharge the capacitance array. The input capacitance, C_i, is also the dynamic load for an external reference during conversion. The dynamic impedance of the reference supply should follow the recommendations on analog-source impedance to allow the charge to settle for 12-bit accuracy.
- (2) The accuracy limits the minimum positive external reference voltage. Lower reference voltage levels may be applied with reduced accuracy requirements.
- (3) The accuracy limits the maximum negative external reference voltage. Higher reference voltage levels may be applied with reduced accuracy requirements.
- (4) The accuracy limits minimum external differential reference voltage. Lower differential reference voltage levels may be applied with reduced accuracy requirements.
- (5) Two decoupling capacitors, 10μF and 100nF, should be connected to VREF to decouple the dynamic current required for an external reference source if it is used for the ADC12_A. See also the *MSP430F5xx/MSP430F6xx Family User's Guide (SLAU208)*.

REF, Built-In Reference

over recommended ranges of supply voltage and operating free-air temperature (unless otherwise noted)⁽¹⁾

PARAMETER		TEST CONDITIONS		V _{CC}	MIN	TYP	MAX	UNIT
V _{REF+}	Positive built-in reference voltage output	REFVSEL = {2} for 2.5 V REFON = REFOUT = 1 I _{VREF+} = 0 A		3 V		2.5	±1%	V
		REFVSEL = {1} for 2 V REFON = REFOUT = 1 I _{VREF+} = 0 A		3 V		2.0	±1%	
		REFVSEL = {0} for 1.5 V REFON = REFOUT = 1 I _{VREF+} = 0 A		2.2 V / 3 V		1.5	±1%	
AV _{CC(min)}	AV _{CC} minimum voltage, Positive built-in reference active	REFVSEL = {0} for 1.5 V			2.2			V
		REFVSEL = {1} for 2 V			2.3			
		REFVSEL = {2} for 2.5 V			2.8			
I _{REF+}	Operating supply current into AV _{CC} terminal ⁽²⁾ ⁽³⁾	ADC12SR = 1 ⁽⁴⁾ , REFON = 1, REFOUT = 0, REFBURST = 0		3V		70	100	μA
		ADC12SR = 1 ⁽⁴⁾ , REFON = 1, REFOUT = 1, REFBURST = 0		3V		0.45	0.75	mA
		ADC12SR = 0 ⁽⁴⁾ , REFON = 1, REFOUT = 0, REFBURST = 0		3V		210	310	μA
		ADC12SR = 0 ⁽⁴⁾ , REFON = 1, REFOUT = 1, REFBURST = 0		3V		0.95	1.7	mA
I _{L(VREF+)}	Load-current regulation, V _{REF+} terminal ⁽⁵⁾	REFVSEL = {0, 1, 2} I _{VREF+} = +10 μA / -1000 μA AV _{CC} = AV _{CC(min)} for each reference level, REFVSEL = {0, 1, 2}, REFON = REFOUT = 1				1500	2500	μV/mA
C _{VREF+}	Capacitance at V _{REF+} terminal	REFON = REFOUT = 1, ⁽⁶⁾ 0 mA ≤ I _{VREF+} ≤ I _{VREF+(max)}		2.2 V/3 V	20		100	pF
TC _{REF+}	Temperature coefficient of built-in reference ⁽⁷⁾	I _{VREF+} is a constant in the range of 0 mA ≤ I _{VREF+} ≤ -1 mA	REFOUT = 0	2.2 V/3 V		20		ppm/°C
TC _{REF+}	Temperature coefficient of built-in reference ⁽⁷⁾	I _{VREF+} is a constant in the range of 0 mA ≤ I _{VREF+} ≤ -1 mA	REFOUT = 1	2.2 V/3 V		20	50	ppm/°C
PSRR _{DC}	Power supply rejection ratio (dc)	AV _{CC} = AV _{CC(min)} - AV _{CC(max)} , T _A = 25°C, REFVSEL = {0, 1, 2}, REFON = 1, REFOUT = 0 or 1				120	300	μV/V
PSRR _{AC}	Power supply rejection ratio (ac)	AV _{CC} = AV _{CC(min)} - AV _{CC(max)} , T _A = 25°C, REFVSEL = {0, 1, 2}, REFON = 1, REFOUT = 0 or 1				1		mV/V

- (1) The reference is supplied to the ADC by the REF module and is buffered locally inside the ADC. The ADC uses two internal buffers, one smaller and one larger for driving the V_{REF+} terminal. When REFOUT = 1, the reference is available at the V_{REF+} terminal, as well as, used as the reference for the conversion and utilizes the larger buffer. When REFOUT = 0, the reference is only used as the reference for the conversion and utilizes the smaller buffer.
- (2) The internal reference current is supplied via terminal AV_{CC}. Consumption is independent of the ADC12ON control bit, unless a conversion is active. REFOUT = 0 represents the current contribution of the smaller buffer. REFOUT = 1 represents the current contribution of the larger buffer without external load.
- (3) The temperature sensor is provided by the REF module. Its current is supplied via terminal AV_{CC} and is equivalent to I_{REF+} with REFON = 1 and REFOUT = 0.
- (4) For devices without the ADC12, the parametric with ADC12SR = 0 are applicable.
- (5) Contribution only due to the reference and buffer including package. This does not include resistance due to PCB trace, etc.
- (6) Two decoupling capacitors, 10μF and 100nF, should be connected to VREF to decouple the dynamic current required for an external reference source if it is used for the ADC12_A. See also the *MSP430F5xx/MSP430F6xx Family User's Guide (SLAU208)*.
- (7) Calculated using the box method: (MAX(-40 to 85°C) - MIN(-40 to 85°C)) / MIN(-40 to 85°C)/(85°C - (-40°C)).

REF, Built-In Reference (continued)

over recommended ranges of supply voltage and operating free-air temperature (unless otherwise noted)⁽¹⁾

PARAMETER		TEST CONDITIONS	V _{CC}	MIN	TYP	MAX	UNIT
t _{SETTLE}	Settling time of reference voltage ⁽⁸⁾	AV _{CC} = AV _{CC(min)} - AV _{CC(max)} , REFVSEL = {0, 1, 2}, REFOUT = 0, REFON = 0 → 1			75		μs
		AV _{CC} = AV _{CC(min)} - AV _{CC(max)} , C _{VREF} = C _{VREF(max)} , REFVSEL = {0, 1, 2}, REFOUT = 1, REFON = 0 → 1			75		

(8) The condition is that the error in a conversion started after t_{REFON} is less than ±0.5 LSB. The settling time depends on the external capacitive load when REFOUT = 1.

12-Bit DAC, Supply Specifications

over recommended ranges of supply voltage and operating free-air temperature (unless otherwise noted)

PARAMETER		TEST CONDITIONS	V _{CC}	MIN	TYP	MAX	UNIT
AV _{CC}	Analog supply voltage	AV _{CC} = DV _{CC} , AV _{SS} = DV _{SS} = 0 V		2.20		3.60	V
I _{DD}	Supply current, single DAC channel ^{(1) (2)}	DAC12AMPx = 2, DAC12IR = 0, DAC12IOG = 1 DAC12_xDAT = 0800h VeREF+ = VREF+ = 1.5 V	3 V		65	110	μA
		DAC12AMPx = 2, DAC12IR = 1, DAC12_xDAT = 0800h, VeREF+ = VREF+ = AV _{CC}			125	165	
		DAC12AMPx = 5, DAC12IR = 1, DAC12_xDAT = 0800h, VeREF+ = VREF+ = AV _{CC}	2.2 V/3 V		250	350	
		DAC12AMPx = 7, DAC12IR = 1, DAC12_xDAT = 0800h, VeREF+ = VREF+ = AV _{CC}			750	1100	
PSRR	Power supply rejection ratio ^{(3) (4)}	DAC12_xDAT = 800h, VeREF+ = 1.5 V, ΔAV _{CC} = 100 mV	2.2 V		70		dB
		DAC12_xDAT = 800h, VeREF+ = 1.5 V or 2.5 V, ΔAV _{CC} = 100 mV	3 V		70		

(1) No load at the output pin, DAC12_0 or DAC12_1, assuming that the control bits for the shared pins are set properly.

(2) Current into reference terminals not included. If DAC12IR = 1 current flows through the input divider; see Reference Input specifications.

(3) PSRR = 20 log (ΔAV_{CC} / ΔV_{DAC12_xOUT})

(4) The internal reference is not used.

12-Bit DAC, Linearity Specifications

over recommended ranges of supply voltage and operating free-air temperature (unless otherwise noted) (see [Figure 17](#))

PARAMETER		TEST CONDITIONS	V _{CC}	MIN	TYP	MAX	UNIT
	Resolution	12-bit monotonic		12			bits
INL	Integral nonlinearity ⁽¹⁾	VeREF+ = 1.5 V, DAC12AMPx = 7, DAC12IR = 1	2.2 V		±2	±4 ⁽²⁾	LSB
		VeREF+ = 2.5 V, DAC12AMPx = 7, DAC12IR = 1	3 V		±2	±4	
DNL	Differential nonlinearity ⁽¹⁾	VeREF+ = 1.5 V, DAC12AMPx = 7, DAC12IR = 1	2.2 V		±0.4	±1 ⁽²⁾	LSB
		VeREF+ = 2.5 V, DAC12AMPx = 7, DAC12IR = 1	3 V		±0.4	±1	

(1) Parameters calculated from the best-fit curve from 0x0F to 0xFFFF. The best-fit curve method is used to deliver coefficients "a" and "b" of the first-order equation: $y = a + bx$. $V_{DAC12_xOUT} = E_0 + (1 + E_g) \times (V_{eREF+}/4095) \times DAC12_xDAT$, DAC12IR = 1.

(2) This parameter is not production tested.

12-Bit DAC, Linearity Specifications (continued)

over recommended ranges of supply voltage and operating free-air temperature (unless otherwise noted) (see Figure 17)

PARAMETER	TEST CONDITIONS	V _{CC}	MIN	TYP	MAX	UNIT	
E _O Offset voltage	Without calibration ^{(1) (3)}	V _{REF+} = 1.5 V, DAC12AMPx = 7, DAC12IR = 1	2.2 V			±21 ⁽²⁾	mV
		V _{REF+} = 2.5 V, DAC12AMPx = 7, DAC12IR = 1	3 V			±21	
	With calibration ^{(1) (3)}	V _{REF+} = 1.5 V, DAC12AMPx = 7, DAC12IR = 1	2.2 V			±1.5 ⁽²⁾	
		V _{REF+} = 2.5 V, DAC12AMPx = 7, DAC12IR = 1	3 V			±1.5	
d _{E(O)/dT} Offset error temperature coefficient ⁽¹⁾	With calibration	2.2 V/3 V		±10		µV/°C	
E _G Gain error	V _{REF+} = 1.5 V	2.2 V			±2.5	%FSR	
	V _{REF+} = 2.5 V	3 V			±2.5		
d _{E(G)/dT} Gain temperature coefficient ⁽¹⁾		2.2 V/3 V		10		ppm of FSR/°C	
t _{Offset_Cal} Time for offset calibration ⁽⁴⁾	DAC12AMPx = 2	2.2 V/3 V			165	ms	
	DAC12AMPx = 3, 5				66		
	DAC12AMPx = 4, 6, 7				16.5		

- (3) The offset calibration works on the output operational amplifier. Offset Calibration is triggered setting bit DAC12CALON
 (4) The offset calibration can be done if DAC12AMPx = {2, 3, 4, 5, 6, 7}. The output operational amplifier is switched off with DAC12AMPx = {0, 1}. It is recommended that the DAC12 module be configured prior to initiating calibration. Port activity during calibration may effect accuracy and is not recommended.

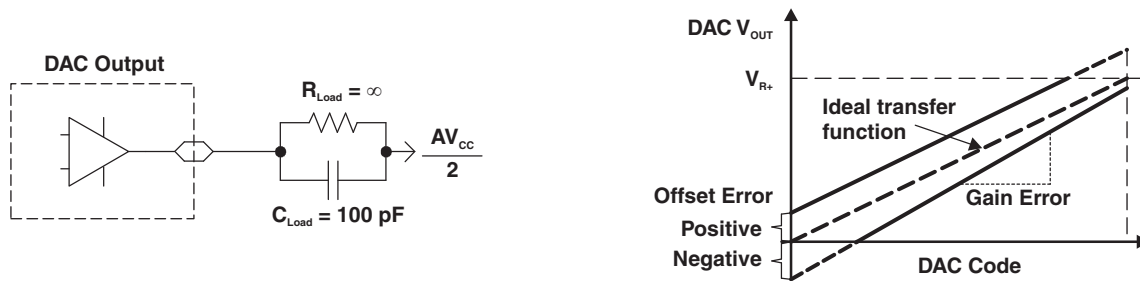

Figure 17. Linearity Test Load Conditions and Gain/Offset Definition

12-Bit DAC, Output Specifications

over recommended ranges of supply voltage and operating free-air temperature (unless otherwise noted)

PARAMETER	TEST CONDITIONS	V _{CC}	MIN	TYP	MAX	UNIT
V _O	No load, V _{REF+} = AV _{CC} , DAC12_xDAT = 0h, DAC12IR = 1, DAC12AMPx = 7	2.2 V/3 V	0		0.005	V
	No load, V _{REF+} = AV _{CC} , DAC12_xDAT = 0FFFh, DAC12IR = 1, DAC12AMPx = 7		AV _{CC} - 0.05		AV _{CC}	
	R _{Load} = 3 kΩ, V _{REF+} = AV _{CC} , DAC12_xDAT = 0h, DAC12IR = 1, DAC12AMPx = 7		0		0.1	
	R _{Load} = 3 kΩ, V _{REF+} = AV _{CC} , DAC12_xDAT = 0FFFh, DAC12IR = 1, DAC12AMPx = 7		AV _{CC} - 0.13		AV _{CC}	
C _{L(DAC12)}	Maximum DAC12 load capacitance	2.2 V/3 V			100	pF
I _{L(DAC12)}	Maximum DAC12 load current	2.2 V/3 V	-1			mA
					1	
R _{O/P(DAC12)}	Output resistance (see Figure 18)	2.2 V/3 V		150	250	Ω
				150	250	

(1) Data is valid after the offset calibration of the output amplifier.

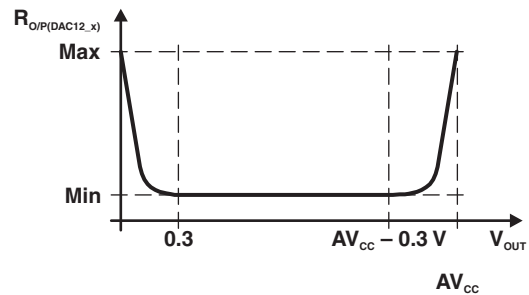
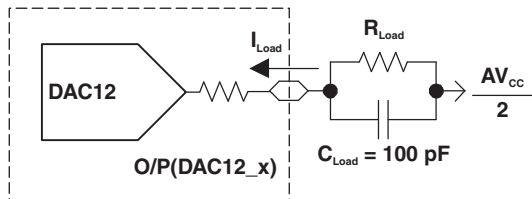

Figure 18. DAC12_x Output Resistance Tests

12-Bit DAC, Reference Input Specifications

over recommended ranges of supply voltage and operating free-air temperature (unless otherwise noted)

PARAMETER		TEST CONDITIONS	V _{CC}	MIN	TYP	MAX	UNIT
V _{REF+}	Reference input voltage range	DAC12IR = 0 ⁽¹⁾ (2)	2.2 V/3 V		AV _{CC} /3	AV _{CC} + 0.2	V
		DAC12IR = 1 ⁽³⁾ (4)			AV _{CC}	AV _{CC} + 0.2	
R _{i(VREF+)} , R _{i(VeREF+)}	Reference input resistance ⁽⁵⁾	DAC12_0 IR = DAC12_1 IR = 0	2.2 V/3 V		20		MΩ
		DAC12_0 IR = 1, DAC12_1 IR = 0			48		
		DAC12_0 IR = 0, DAC12_1 IR = 1			48		kΩ
		DAC12_0 IR = DAC12_1 IR = 1, DAC12_0 SREFx = DAC12_1 SREFx ⁽⁶⁾			24		

- (1) For a full-scale output, the reference input voltage can be as high as 1/3 of the maximum output voltage swing (AV_{CC}).
- (2) The maximum voltage applied at reference input voltage terminal V_{REF+} = [AV_{CC} - V_{E(O)}] / [3 × (1 + E_G)].
- (3) For a full-scale output, the reference input voltage can be as high as the maximum output voltage swing (AV_{CC}).
- (4) The maximum voltage applied at reference input voltage terminal V_{REF+} = [AV_{CC} - V_{E(O)}] / (1 + E_G).
- (5) This impedance depends on tradeoff in power savings. Current devices have 48 kΩ for each channel when divide is enabled. Can be increased if performance can be maintained.
- (6) When DAC12IR = 1 and DAC12SREFx = 0 or 1 for both channels, the reference input resistive dividers for each DAC are in parallel reducing the reference input resistance.

12-Bit DAC, Dynamic Specifications

V_{REF} = V_{CC}, DAC12IR = 1 (see Figure 19 and Figure 20), over recommended ranges of supply voltage and operating free-air temperature (unless otherwise noted)

PARAMETER		TEST CONDITIONS	V _{CC}	MIN	TYP	MAX	UNIT	
t _{ON}	DAC12 on time	DAC12_xDAT = 800h, Error _{V(O)} < ±0.5 LSB ⁽¹⁾ (see Figure 19)	2.2 V/3 V		60	120	μs	
		DAC12AMPx = 0 → {2, 3, 4}			15	30		
		DAC12AMPx = 0 → {5, 6}			6	12		
t _{S(FS)}	Settling time, full scale	DAC12_xDAT = 80h → F7Fh → 80h	2.2 V/3 V		100	200	μs	
					DAC12AMPx = 2	40		80
					DAC12AMPx = 3, 5	15		30
t _{S(C-C)}	Settling time, code to code	DAC12_xDAT = 3F8h → 408h → 3F8h, BF8h → C08h → BF8h	2.2 V/3 V		5		μs	
					DAC12AMPx = 2	2		
					DAC12AMPx = 3, 5	1		
SR	Slew rate	DAC12_xDAT = 80h → F7Fh → 80h ⁽²⁾	2.2 V/3 V		0.05	0.35	V/μs	
					DAC12AMPx = 2	0.35		1.10
					DAC12AMPx = 3, 5	1.50		5.20
Glitch energy		DAC12_xDAT = 800h → 7FFh → 800h	2.2 V/3 V		35		nV-s	

- (1) R_{Load} and C_{Load} connected to AV_{SS} (not AV_{CC}/2) in Figure 19.
- (2) Slew rate applies to output voltage steps ≥ 200 mV.

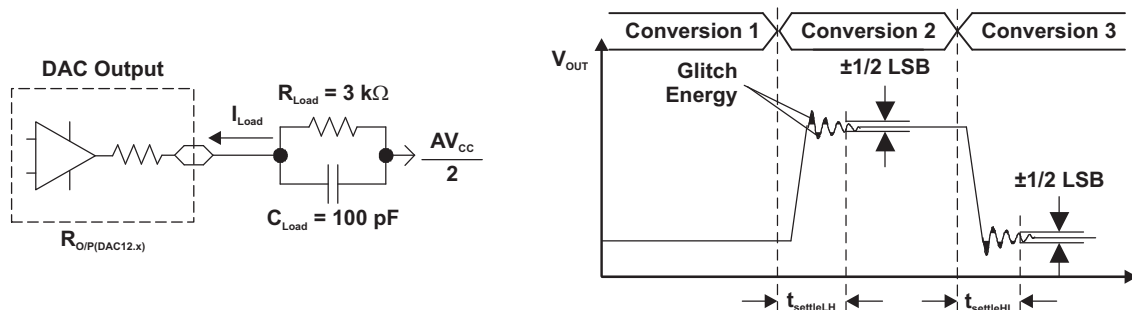

Figure 19. Settling Time and Glitch Energy Testing

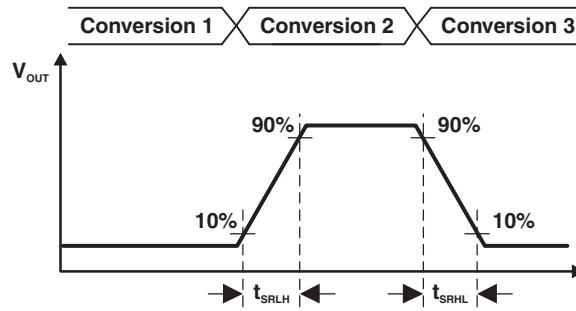

Figure 20. Slew Rate Testing

12-Bit DAC, Dynamic Specifications (Continued)

over recommended ranges of supply voltage and $T_A = 25^\circ\text{C}$ (unless otherwise noted)

PARAMETER	TEST CONDITIONS	V_{CC}	MIN	TYP	MAX	UNIT
BW_{-3dB} 3-dB bandwidth, $V_{DC} = 1.5\text{ V}$, $V_{AC} = 0.1\text{ V}_{PP}$ (see Figure 21)	$DAC12AMPx = \{2, 3, 4\}$, $DAC12SREFx = 2$, $DAC12IR = 1$, $DAC12_xDAT = 800h$	2.2 V/3 V	40			kHz
	$DAC12AMPx = \{5, 6\}$, $DAC12SREFx = 2$, $DAC12IR = 1$, $DAC12_xDAT = 800h$		180			
	$DAC12AMPx = 7$, $DAC12SREFx = 2$, $DAC12IR = 1$, $DAC12_xDAT = 800h$		550			
Channel-to-channel crosstalk ⁽¹⁾ (see Figure 22)	$DAC12_0DAT = 800h$, No load, $DAC12_1DAT = 80h \leftrightarrow F7Fh$, $R_{Load} = 3\text{ k}\Omega$, $f_{DAC12_0OUT} = 10\text{ kHz}$ at 50/50 duty cycle	2.2 V/3 V		-80		dB
	$DAC12_0DAT = 80h \leftrightarrow F7Fh$, $R_{Load} = 3\text{ k}\Omega$, $DAC12_1DAT = 800h$, No load, $f_{DAC12_0OUT} = 10\text{ kHz}$ at 50/50 duty cycle			-80		

(1) $R_{Load} = 3\text{ k}\Omega$, $C_{Load} = 100\text{ pF}$

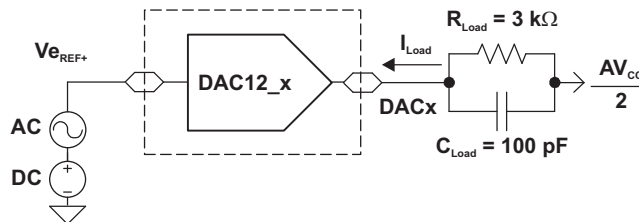

Figure 21. Test Conditions for 3-dB Bandwidth Specification

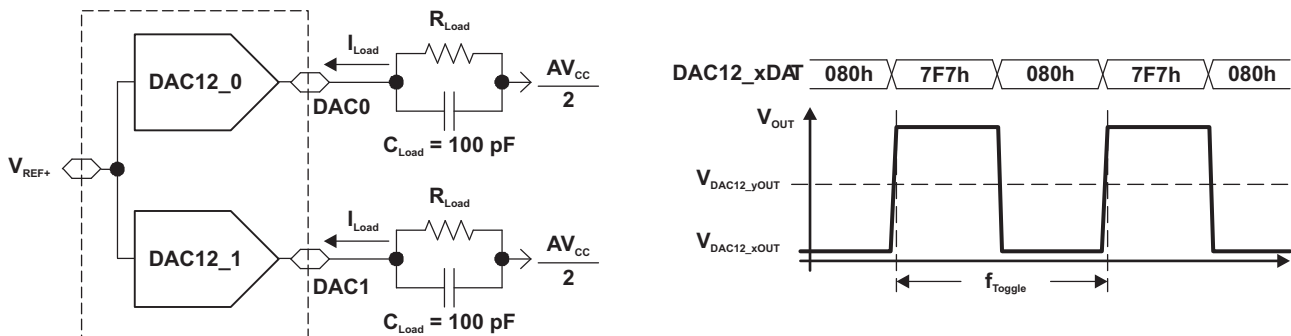

Figure 22. Crosstalk Test Conditions

Comparator_B

over recommended ranges of supply voltage and operating free-air temperature (unless otherwise noted)

PARAMETER	TEST CONDITIONS	V _{CC}	MIN	TYP	MAX	UNIT	
V _{CC}	Supply voltage		1.8		3.6	V	
I _{AVCC_COMP}	Comparator operating supply current into AV _{CC} terminal, Excludes reference resistor ladder	CBPWRMD = 00	1.8 V		40	μA	
			2.2 V		30		
			3 V		40		
		CBPWRMD = 01	2.2 V / 3 V		10		30
		CBPWRMD = 10	2.2 V / 3 V		0.1		0.5
I _{AVCC_REF}	Quiescent current of local reference voltage amplifier into AV _{CC} terminal				22	μA	
V _{IC}	Common mode input range		0		V _{CC} - 1	V	
V _{OFFSET}	Input offset voltage	CBPWRMD = 00			±20	mV	
		CBPWRMD = 01, 10			±10		
C _{IN}	Input capacitance			5		pF	
R _{SIN}	Series input resistance	ON - switch closed			3	4	kΩ
		OFF - switch opened		50			MΩ
t _{PD}	Propagation delay, response time	CBPWRMD = 00, CBF = 0				450	ns
		CBPWRMD = 01, CBF = 0				600	ns
		CBPWRMD = 10, CBF = 0					50
t _{PD,filter}	Propagation delay with filter active	CBPWRMD = 00, CBON = 1, CBF = 1, CBF _{DLY} = 00		0.35	0.6	1.0	μs
		CBPWRMD = 00, CBON = 1, CBF = 1, CBF _{DLY} = 01		0.6	1.0	1.8	μs
		CBPWRMD = 00, CBON = 1, CBF = 1, CBF _{DLY} = 10		1.0	1.8	3.4	μs
		CBPWRMD = 00, CBON = 1, CBF = 1, CBF _{DLY} = 11		1.8	3.4	6.5	μs
t _{EN_CMP}	Comparator enable time, settling time	CBON = 0 to CBON = 1 CBPWRMD = 00, 01, 10			1	2	μs
t _{EN_REF}	Resistor reference enable time	CBON = 0 to CBON = 1			0.3	1.5	μs
V _{CB_REF}	Reference voltage for a given tap	V _{IN} = reference into resistor ladder, n = 0 to 31		$\frac{V_{IN} \times (n+0.5)}{32}$	$\frac{V_{IN} \times (n+1)}{32}$	$\frac{V_{IN} \times (n+1.5)}{32}$	V

Ports PU.0 and PU.1

over recommended ranges of supply voltage and operating free-air temperature (unless otherwise noted)

PARAMETER		TEST CONDITIONS	V _{CC}	MIN	TYP	MAX	UNIT
V _{OH}	High-level output voltage	V _{USB} = 3.3 V ± 10%, I _{OH} = -25 mA		2.4			V
V _{OL}	Low-level output voltage	V _{USB} = 3.3 V ± 10%, I _{OL} = 25 mA				0.4	V
V _{IH}	High-level input voltage	V _{USB} = 3.3 V ± 10%		2.0			V
V _{IL}	Low-level input voltage	V _{USB} = 3.3 V ± 10%				0.8	V

USB Output Ports DP and DM

over recommended ranges of supply voltage and operating free-air temperature (unless otherwise noted)

PARAMETER		TEST CONDITIONS	MIN	TYP	MAX	UNIT
V _{OH}	D+, D- single ended	USB 2.0 load conditions	2.8		3.6	V
V _{OL}	D+, D- single ended	USB 2.0 load conditions	0		0.3	V
Z _(DRV)	D+, D- impedance	Including external series resistor of 27 Ω	28		44	Ω
t _{RISE}	Rise time	Full speed, differential, C _L = 50 pF, 10%/90%, R _{pu} on D+	4		20	ns
t _{FALL}	Fall time	Full speed, differential, C _L = 50 pF, 10%/90%, R _{pu} on D+	4		20	ns

USB Input Ports DP and DM

over recommended ranges of supply voltage and operating free-air temperature (unless otherwise noted)

PARAMETER		TEST CONDITIONS	MIN	TYP	MAX	UNIT
V _(CM)	Differential input common mode range		0.8		2.5	V
Z _(IN)	Input impedance		300			kΩ
V _{CRS}	Crossover voltage		1.3		2.0	V
V _{IL}	Static SE input logic low level		0.8			V
V _{IH}	Static SE input logic high level				2.0	V
V _{DI}	Differential input voltage				0.2	V

USB-PWR (USB Power System)

over recommended ranges of supply voltage and operating free-air temperature (unless otherwise noted)

PARAMETER		TEST CONDITIONS	MIN	TYP	MAX	UNIT
V _{LAUNCH}	V _{BUS} detection threshold				3.75	V
V _{BUS}	USB bus voltage	Normal operation	3.76		5.5	V
V _{USB}	USB LDO output voltage			3.3	±9%	V
V ₁₈	Internal USB voltage ⁽¹⁾			1.8		V
I _{USB_EXT}	Maximum external current from V _{USB} terminal ⁽²⁾	USB LDO is on			12	mA
I _{DET}	USB LDO current overload detection ⁽³⁾		60		100	mA
I _{SUSPEND}	Operating supply current into V _{BUS} terminal. ⁽⁴⁾	USB LDO is on, USB PLL disabled			250	μA
C _{BUS}	V _{BUS} terminal recommended capacitance			4.7		μF
C _{USB}	V _{USB} terminal recommended capacitance			220		nF
C ₁₈	V ₁₈ terminal recommended capacitance			220		nF
t _{ENABLE}	Settling time V _{USB} and V ₁₈	Within 2%, recommended capacitances			2	ms
RPUR	Pullup resistance of PUR terminal		70	110	150	Ω

(1) This voltage is for internal use only. No external dc loading should be applied.

(2) This represents additional current that can be supplied to the application from the V_{USB} terminal beyond the needs of the USB operation.

(3) A current overload is detected when the total current supplied from the USB LDO, including I_{USB_EXT}, exceeds this value.

(4) Does not include current contribution of R_{pu} and R_{pd} as outlined in the USB specification.

USB-PLL (USB Phase-Locked Loop)

over recommended ranges of supply voltage and operating free-air temperature (unless otherwise noted)

PARAMETER	TEST CONDITIONS	V _{CC}	MIN	TYP	MAX	UNIT
I _{PLL}	Operating supply current				7	mA
f _{PLL}	PLL frequency			48		MHz
f _{UPD}	PLL reference frequency		1.5		3	MHz
t _{LOCK}	PLL lock time				2	ms
t _{Jitter}	PLL jitter			1000		ps

Flash Memory

over recommended ranges of supply voltage and operating free-air temperature (unless otherwise noted)

PARAMETER	TEST CONDITIONS	MIN	TYP	MAX	UNIT
DV _{CC(PGM/ERASE)}	Program and erase supply voltage	1.8		3.6	V
I _{PGM}	Average supply current from DV _{CC} during program		3	5	mA
I _{ERASE}	Average supply current from DV _{CC} during erase			2.5	mA
I _{MERASE} , I _{BANK}	Average supply current from DV _{CC} during mass erase or bank erase			2	mA
t _{CPT}	Cumulative program time	See ⁽¹⁾		16	ms
	Program/erase endurance		10 ⁴	10 ⁵	cycles
t _{Retention}	Data retention duration	T _J = 25°C	100		years
t _{Word}	Word or byte program time	See ⁽²⁾	64	85	μs
t _{Block, 0}	Block program time for first byte or word	See ⁽²⁾	49	65	μs
t _{Block, 1–(N–1)}	Block program time for each additional byte or word, except for last byte or word	See ⁽²⁾	37	49	μs
t _{Block, N}	Block program time for last byte or word	See ⁽²⁾	55	73	μs
t _{Seg Erase}	Erase time for segment, mass erase, and bank erase when available	See ⁽²⁾	23	32	ms
f _{MCLK,MGR}	MCLK frequency in marginal read mode (FCTL4.MGR0 = 1 or FCTL4.MGR1 = 1)		0	1	MHz

(1) The cumulative program time must not be exceeded when writing to a 128-byte flash block. This parameter applies to all programming methods: individual word/byte write and block write modes.

(2) These values are hardwired into the flash controller's state machine.

JTAG and Spy-Bi-Wire Interface

over recommended ranges of supply voltage and operating free-air temperature (unless otherwise noted)

PARAMETER	TEST CONDITIONS	MIN	TYP	MAX	UNIT	
f _{SBW}	Spy-Bi-Wire input frequency	2.2 V/3 V	0	20	MHz	
t _{SBW,Low}	Spy-Bi-Wire low clock pulse length	2.2 V/3 V	0.025	15	μs	
t _{SBW,En}	Spy-Bi-Wire enable time (TEST high to acceptance of first clock edge) ⁽¹⁾	2.2 V/3 V		1	μs	
t _{SBW,Rst}	Spy-Bi-Wire return to normal operation time		15	100	μs	
f _{TCK}	TCK input frequency - 4-wire JTAG ⁽²⁾	2.2 V	0	5	MHz	
		3 V	0	10	MHz	
R _{Internal}	Internal pull-down resistance on TEST	2.2 V/3 V	45	60	80	kΩ

(1) Tools accessing the Spy-Bi-Wire interface need to wait for the t_{SBW,En} time after pulling the TEST/SBWTCK pin high before applying the first SBWTCK clock edge.

(2) f_{TCK} may be restricted to meet the timing requirements of the module selected.

INPUT/OUTPUT SCHEMATICS

Port P1, P1.0 to P1.7, Input/Output With Schmitt Trigger

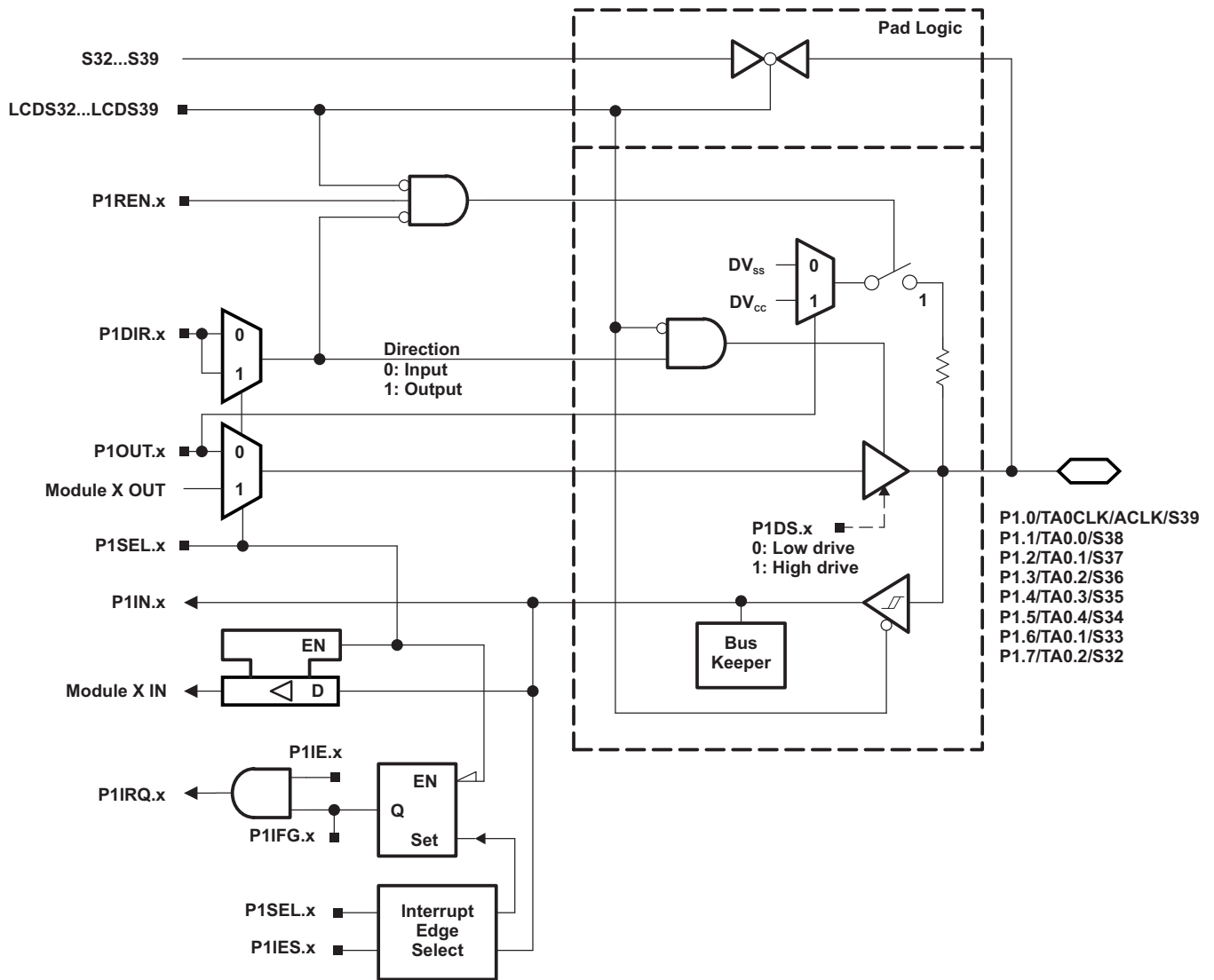

Table 55. Port P1 (P1.0 to P1.7) Pin Functions

PIN NAME (P1.x)	x	FUNCTION	CONTROL BITS/SIGNALS		
			P1DIR.x	P1SEL.x	LCDS32...39
P1.0/TA0CLK/ACLK/ S39	0	P1.0 (I/O)	I: 0; O: 1	0	0
		Timer TA0.TA0CLK	0	1	0
		ACLK	1	1	0
		S39	X	X	1
P1.1/TA0.0/S38	1	P1.1 (I/O)	I: 0; O: 1	0	0
		Timer TA0.CCI0A capture input	0	1	0
		Timer TA0.0 output	1	1	0
		S38	X	X	1
P1.2/TA0.1/S37	2	P1.2 (I/O)	I: 0; O: 1	0	0
		Timer TA0.CCI1A capture input	0	1	0
		Timer TA0.1 output	1	1	0
		S37	X	X	1
P1.3/TA0.2/S36	3	P1.3 (I/O)	I: 0; O: 1	0	0
		Timer TA0.CCI2A capture input	0	1	0
		Timer TA0.2 output	1	1	0
		S36	X	X	1
P1.4/TA0.3/S35	4	P1.4 (I/O)	I: 0; O: 1	0	0
		Timer TA0.CCI3A capture input	0	1	0
		Timer TA0.3 output	1	1	0
		S35	X	X	1
P1.5/TA0.4/S34	5	P1.5 (I/O)	I: 0; O: 1	0	0
		Timer TA0.CCI4A capture input	0	1	0
		Timer TA0.4 output	1	1	0
		S34	X	X	1
P1.6/TA0.1/S33	6	P1.6 (I/O)	I: 0; O: 1	0	0
		Timer TA0.CCI1B capture input	0	1	0
		Timer TA0.1 output	1	1	0
		S33	X	X	1
P1.7/TA0.2/S32	7	P1.7 (I/O)	I: 0; O: 1	0	0
		Timer TA0.CCI2B capture input	0	1	0
		Timer TA0.2 output	1	1	0
		S32	X	X	1

Port P2, P2.0 to P2.7, Input/Output With Schmitt Trigger

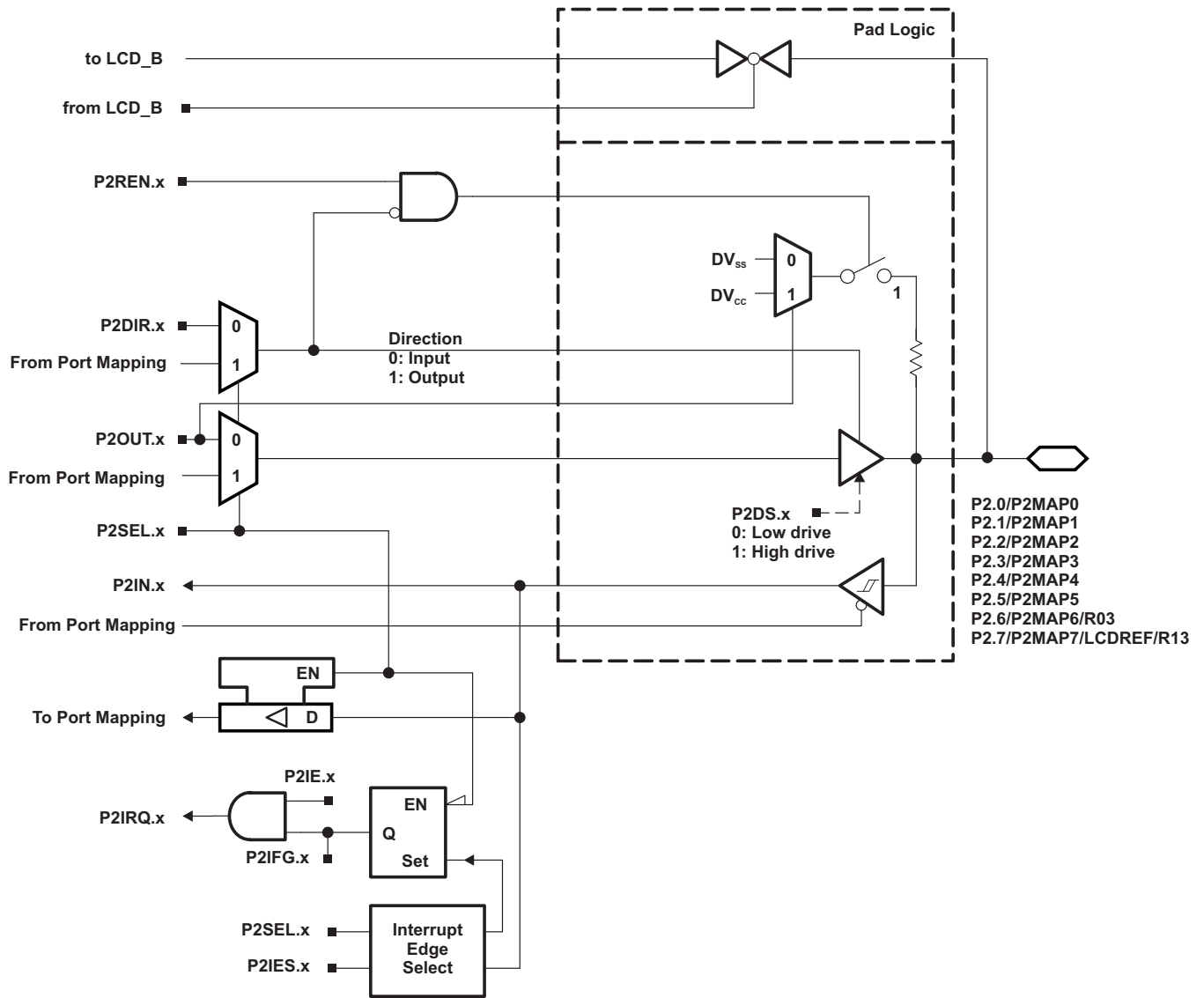

Table 56. Port P2 (P2.0 to P2.7) Pin Functions

PIN NAME (P2.x)	x	FUNCTION	CONTROL BITS/SIGNALS ⁽¹⁾		
			P2DIR.x	P2SEL.x	P2MAPx
P2.0/P2MAP0	0	P2.0 (I/O)	I: 0; O: 1	0	
		Mapped secondary digital function	X	1	≤ 19
P2.1/P2MAP1	1	P2.1 (I/O)	I: 0; O: 1	0	
		Mapped secondary digital function	X	1	≤ 19
P2.2/P2MAP2	2	P2.2 (I/O)	I: 0; O: 1	0	
		Mapped secondary digital function	X	1	≤ 19
P2.3/P2MAP3	3	P2.3 (I/O)	I: 0; O: 1	0	
		Mapped secondary digital function	X	1	≤ 19
P2.4/P2MAP4	4	P2.4 (I/O)	I: 0; O: 1	0	
		Mapped secondary digital function	X	1	≤ 19
P2.5/P2MAP5	5	P2.5 (I/O)	I: 0; O: 1	0	
		Mapped secondary digital function	X	1	≤ 19
P2.6/P2MAP6/R03	6	P2.6 (I/O)	I: 0; O: 1	0	
		Mapped secondary digital function	X	1	≤ 19
		R03	X	1	= 31
P2.7/P2MAP7/ LCDREF/R13	7	P2.7 (I/O)	I: 0; O: 1	0	
		Mapped secondary digital function	X	1	≤ 19
		LCDREF/R13	X	1	= 31

(1) X = Don't care

Port P3, P3.0 to P3.7, Input/Output With Schmitt Trigger

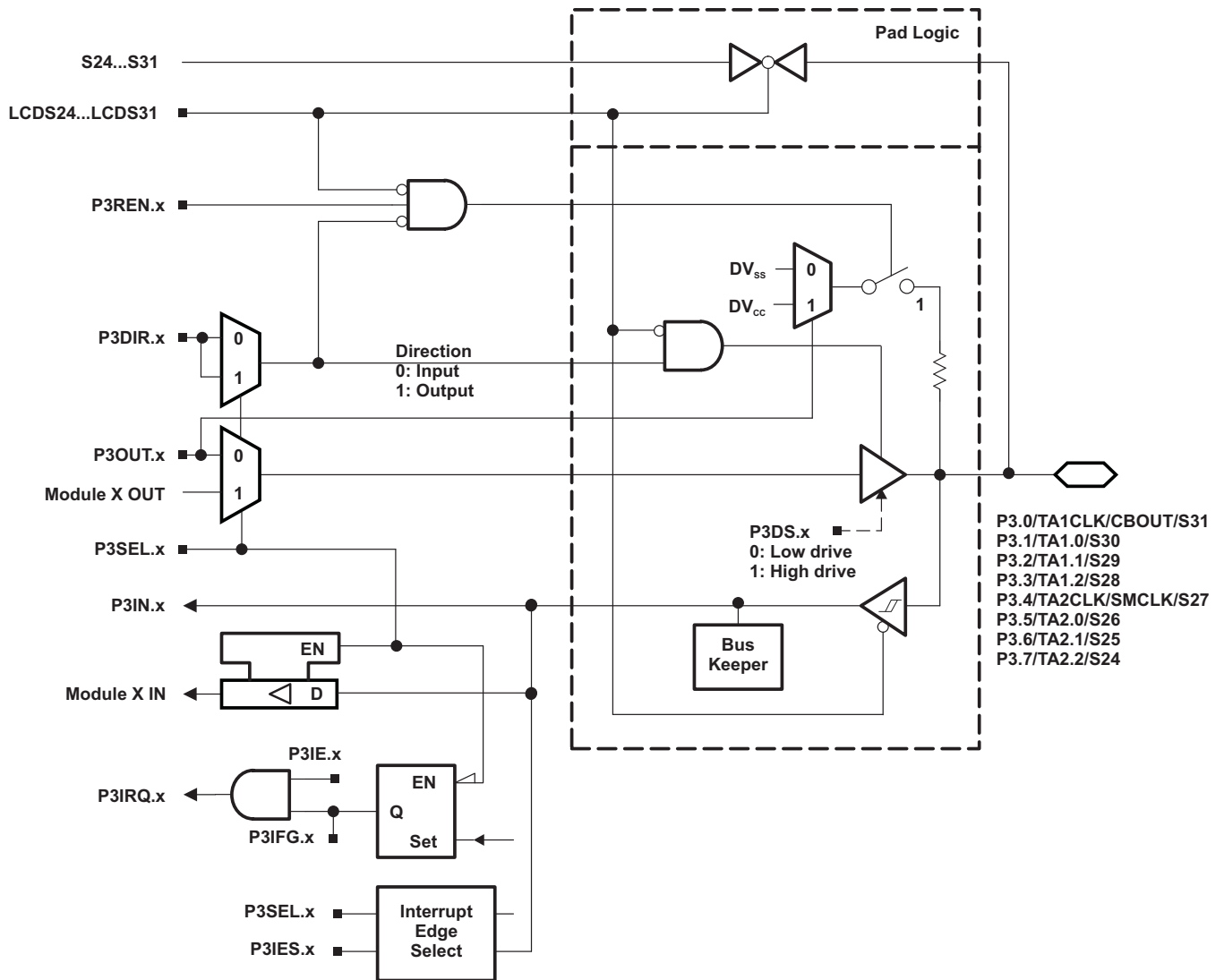

Table 57. Port P3 (P3.0 to P3.7) Pin Functions

PIN NAME (P3.x)	x	FUNCTION	CONTROL BITS/SIGNALS		
			P3DIR.x	P3SEL.x	LCDS24...31
P3.0/TA1CLK/CBOUT/S31	0	P3.0 (I/O)	I: 0; O: 1	0	0
		Timer TA1.TA1CLK	0	1	0
		CBOUT	1	1	0
		S31	X	X	1
P3.1/TA1.0/S30	1	P3.1 (I/O)	I: 0; O: 1	0	0
		Timer TA1.CCI0A capture input	0	1	0
		Timer TA1.0 output	1	1	0
		S30	X	X	1
P3.2/TA1.1/S29	2	P3.2 (I/O)	I: 0; O: 1	0	0
		Timer TA1.CCI1A capture input	0	1	0
		Timer TA1.1 output	1	1	0
		S29	X	X	1
P3.3/TA1.2/S28	3	P3.3 (I/O)	I: 0; O: 1	0	0
		Timer TA1.CCI2A capture input	0	1	0
		Timer TA1.2 output	1	1	0
		S28	X	X	1
P3.4/TA2CLK/SMCLK/S27	4	P3.4 (I/O)	I: 0; O: 1	0	0
		Timer TA2.TA2CLK	0	1	0
		SMCLK	1	1	0
		S27	X	X	1
P3.5/TA2.0/S26	5	P3.5 (I/O)	I: 0; O: 1	0	0
		Timer TA2.CCI0A capture input	0	1	0
		Timer TA2.0 output	1	1	0
		S26	X	X	1
P3.6/TA2.1/S25	6	P3.6 (I/O)	I: 0; O: 1	0	0
		Timer TA2.CCI1A capture input	0	1	0
		Timer TA2.1 output	1	1	1
		S25	X	X	1
P3.7/TA2.2/S24	7	P3.7 (I/O)	I: 0; O: 1	0	0
		Timer TA2.CCI2A capture input	0	1	0
		Timer TA2.2 output	1	1	0
		S24	X	X	1

Port P4, P4.0 to P4.7, Input/Output With Schmitt Trigger

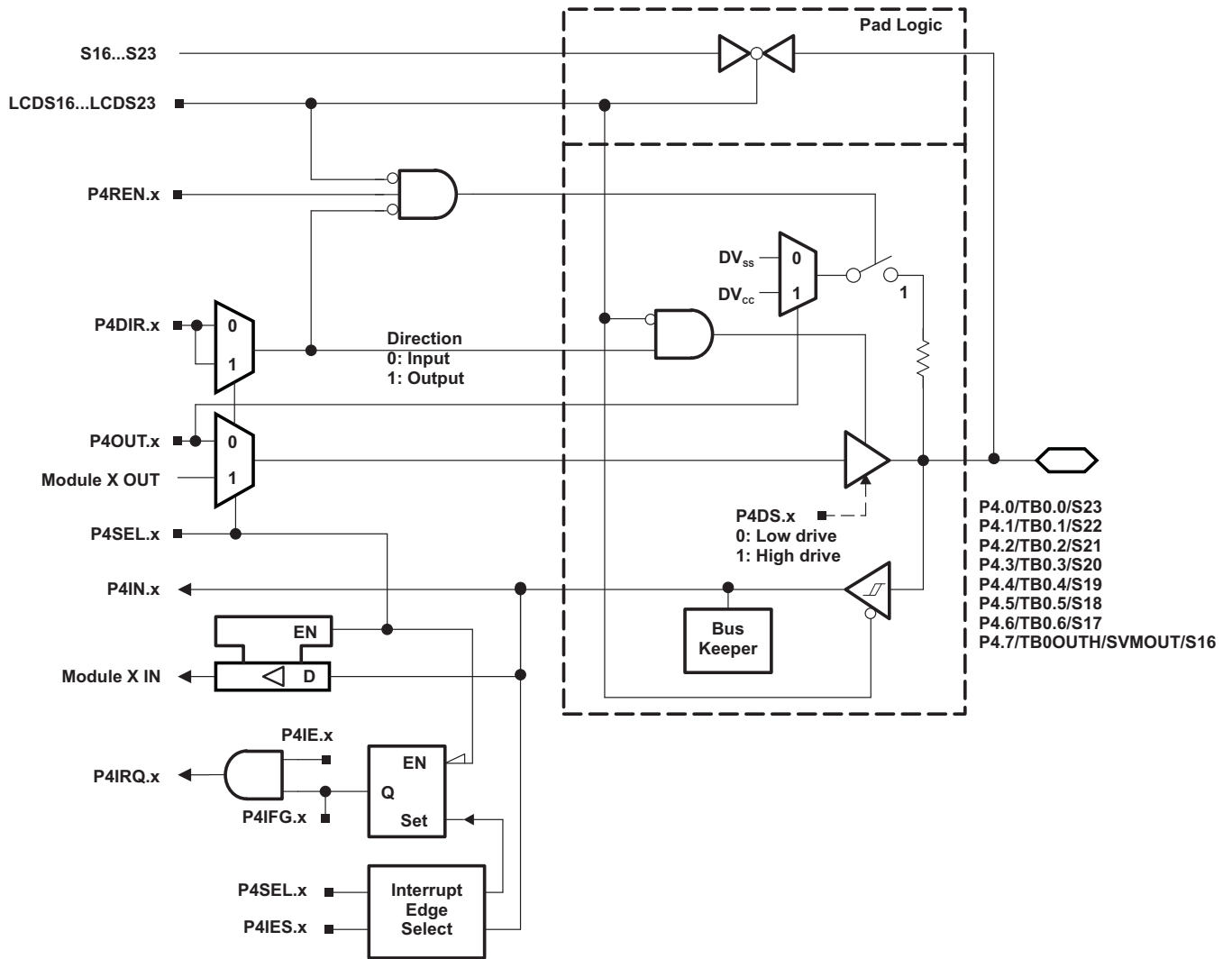

Table 58. Port P4 (P4.0 to P4.7) Pin Functions

PIN NAME (P4.x)	x	FUNCTION	CONTROL BITS/SIGNALS		
			P4DIR.x	P4SEL.x	LCDS16...23
P4.0/TB0.0/S23	0	P4.0 (I/O)	I: 0; O: 1	0	0
		Timer TB0.CCI0A capture input	0	1	0
		Timer TB0.0 output ⁽¹⁾	1	1	0
		S23	X	X	1
P4.1/TB0.1/S22	1	P4.1 (I/O)	I: 0; O: 1	0	0
		Timer TB0.CCI1A capture input	0	1	0
		Timer TB0.1 output ⁽¹⁾	1	1	0
		S22	X	X	1
P4.2/TB0.2/S21	2	P4.2 (I/O)	I: 0; O: 1	0	0
		Timer TB0.CCI2A capture input	0	1	0
		Timer TB0.2 output ⁽¹⁾	1	1	0
		S21	X	X	1
P4.3/TB0.3/S20	3	P4.3 (I/O)	I: 0; O: 1	0	0
		Timer TB0.CCI3A capture input	0	1	0
		Timer TB0.3 output ⁽¹⁾	1	1	0
		S20	X	X	1
P4.4/TB0.4/S19	4	P4.4 (I/O)	I: 0; O: 1	0	0
		Timer TB0.CCI4A capture input	0	1	0
		Timer TB0.4 output ⁽¹⁾	1	1	0
		S19	X	X	1
P4.5/TB0.5/S18	5	P4.5 (I/O)	I: 0; O: 1	0	0
		Timer TB0.CCI5A capture input	0	1	0
		Timer TB0.5 output ⁽¹⁾	1	1	0
		S18	X	X	1
P4.6/TB0.6/S17	6	P4.6 (I/O)	I: 0; O: 1	0	0
		Timer TB0.CCI6A capture input	0	1	0
		Timer TB0.6 output ⁽¹⁾	1	1	0
		S17	X	X	1
P4.7/TB0OUTH/ SVMOUT/S16	7	P4.7 (I/O)	I: 0; O: 1	0	0
		Timer TB0.TB0OUTH	0	1	0
		SVMOUT	1	1	0
		S16	X	X	1

(1) Setting TB0OUTH causes all Timer_B configured outputs to be set to high impedance.

Port P5, P5.0 and P5.1, Input/Output With Schmitt Trigger

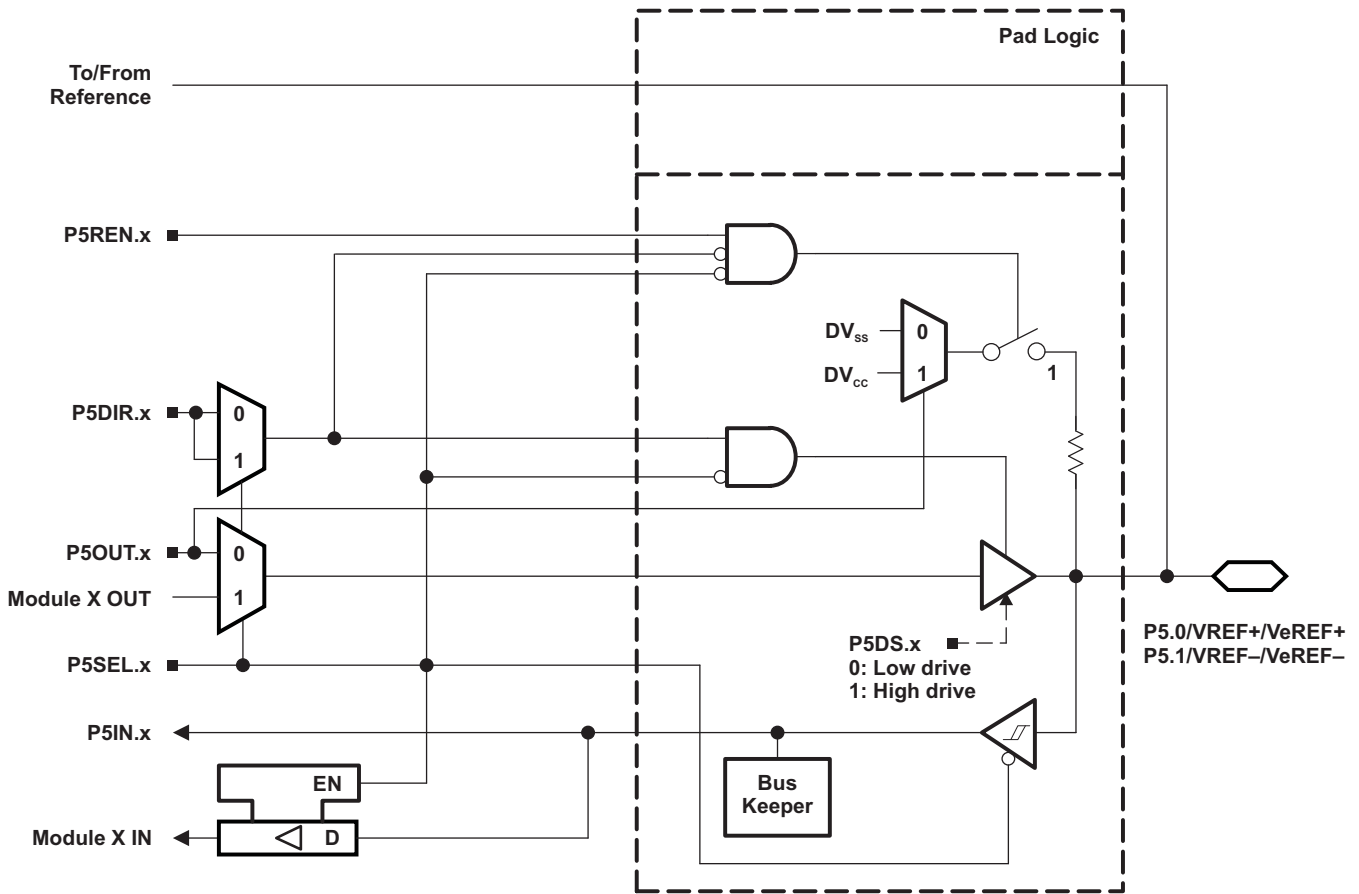

Table 59. Port P5 (P5.0 and P5.1) Pin Functions

PIN NAME (P5.x)	x	FUNCTION	CONTROL BITS/SIGNALS ⁽¹⁾		
			P5DIR.x	P5SEL.x	REFOUT
P5.0/VREF+/VeREF+	0	P5.0 (I/O) ⁽²⁾	I: 0; O: 1	0	X
		VeREF+ ⁽³⁾	X	1	0
		VREF+ ⁽⁴⁾	X	1	1
P5.1/VREF-/VeREF-	1	P5.1 (I/O) ⁽²⁾	I: 0; O: 1	0	X
		VeREF- ⁽⁵⁾	X	1	0
		VREF- ⁽⁶⁾	X	1	1

- (1) X = Don't care
- (2) Default condition
- (3) Setting the P5SEL.0 bit disables the output driver as well as the input Schmitt trigger to prevent parasitic cross currents when applying analog signals. An external voltage can be applied to VeREF+ and used as the reference for the ADC12_A, Comparator_B, or DAC12_A.
- (4) Setting the P5SEL.0 bit disables the output driver as well as the input Schmitt trigger to prevent parasitic cross currents when applying analog signals. The ADC12_A, VREF+ reference is available at the pin.
- (5) Setting the P5SEL.1 bit disables the output driver as well as the input Schmitt trigger to prevent parasitic cross currents when applying analog signals. An external voltage can be applied to VeREF- and used as the reference for the ADC12_A, Comparator_B, or DAC12_A.
- (6) Setting the P5SEL.1 bit disables the output driver as well as the input Schmitt trigger to prevent parasitic cross currents when applying analog signals. The ADC12_A, VREF- reference is available at the pin.

Port P5, P5.2 to P5.7, Input/Output With Schmitt Trigger

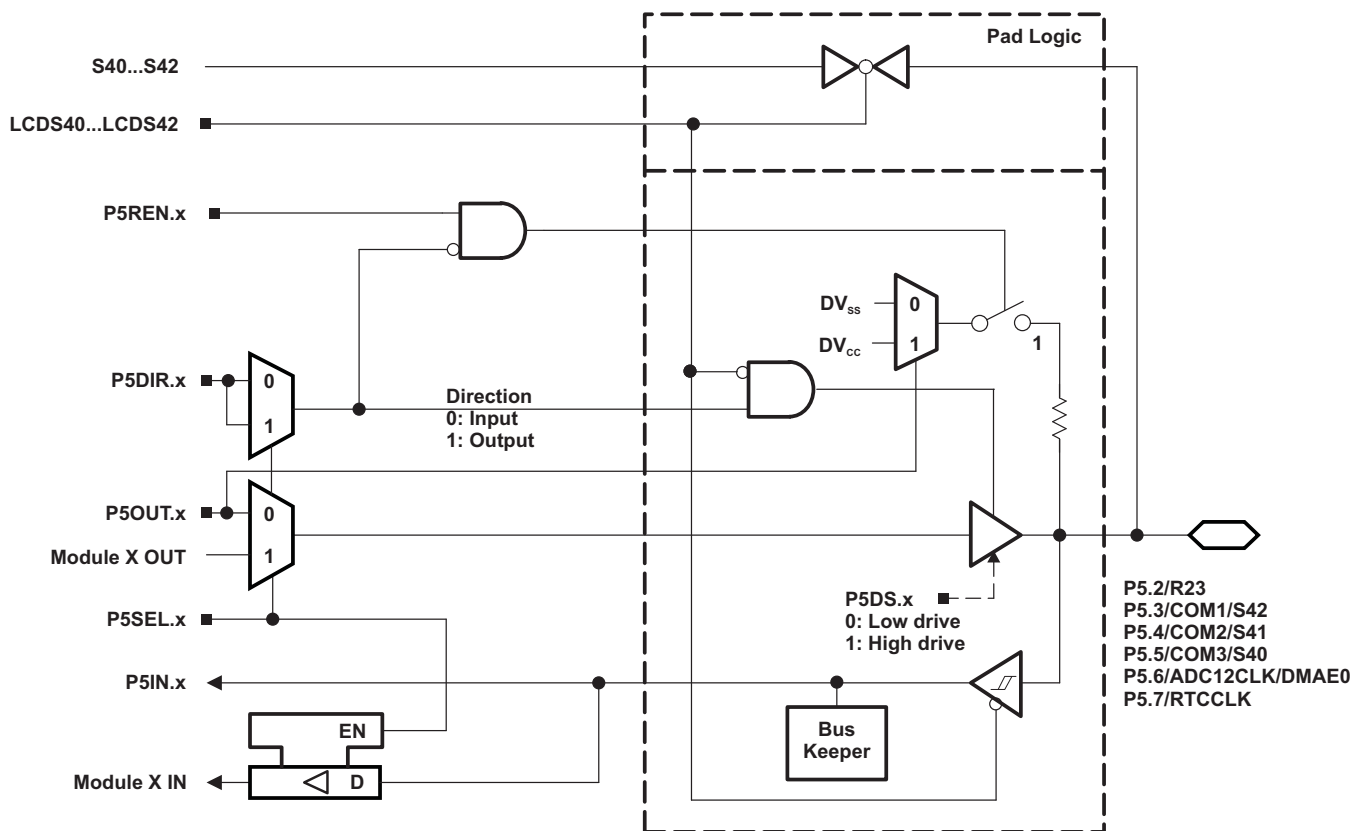

Table 60. Port P5 (P5.2 to P5.7) Pin Functions

PIN NAME (P5.x)	x	FUNCTION	CONTROL BITS/SIGNALS ⁽¹⁾		
			P5DIR.x	P5SEL.x	LCDS40...42
P5.2/R23	2	P5.2 (I/O)	I: 0; O: 1	0	na
		R23	X	1	na
P5.3/COM1/S42	3	P5.3 (I/O)	I: 0; O: 1	0	0
		COM1	X	1	X
		S42	X	0	1
P5.4/COM2/S41	4	P5.4 (I/O)	I: 0; O: 1	0	0
		COM2	X	1	X
		S41	X	0	1
P5.5/COM3/S40	5	P5.5 (I/O)	I: 0; O: 1	0	0
		COM3	X	1	X
		S40	X	0	1
P5.6/ADC12CLK/DMAE0	6	P5.6 (I/O)	I: 0; O: 1	0	na
		ADC12CLK	1	1	na
		DMAE0	0	1	na
P5.7/RTCCLK	7	P5.7 (I/O)	I: 0; O: 1	0	na
		RTCCLK	1	1	na

(1) X = Don't care

Port P6, P6.0 to P6.7, Input/Output With Schmitt Trigger

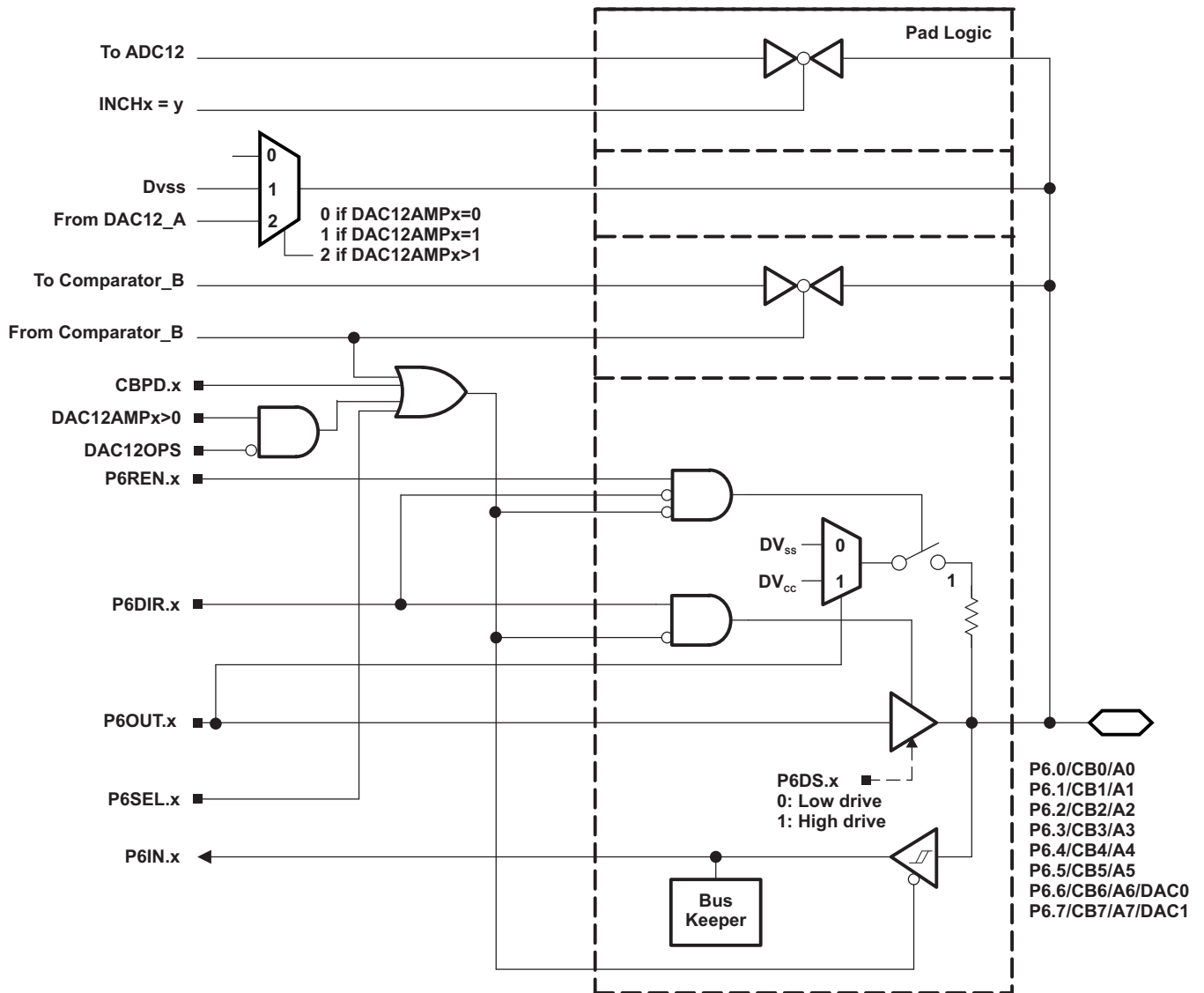

Table 61. Port P6 (P6.0 to P6.7) Pin Functions

PIN NAME (P6.x)	x	FUNCTION	CONTROL BITS/SIGNALS ⁽¹⁾				
			P6DIR.x	P6SEL.x	CBPD.x	DAC12OPS	DAC12AMPx
P6.0/CB0/A0	0	P6.0 (I/O)	I: 0; O: 1	0	0	n/a	n/a
		CB0	X	X	1	n/a	n/a
		A0 ^{(2) (3)}	X	1	X	n/a	n/a
P6.1/CB1/A1	1	P6.1 (I/O)	I: 0; O: 1	0	0	n/a	n/a
		CB1	X	X	1	n/a	n/a
		A1 ^{(2) (3)}	X	1	X	n/a	n/a
P6.2/CB2/A2	2	P6.2 (I/O)	I: 0; O: 1	0	0	n/a	n/a
		CB2	X	X	1	n/a	n/a
		A2 ^{(2) (3)}	X	1	X	n/a	n/a
P6.3/CB3/A3	3	P6.3 (I/O)	I: 0; O: 1	0	0	n/a	n/a
		CB3	X	X	1	n/a	n/a
		A3 ^{(2) (3)}	X	1	X	n/a	n/a
P6.4/CB4/A4	4	P6.4 (I/O)	I: 0; O: 1	0	0	n/a	n/a
		CB4	X	X	1	n/a	n/a
		A4 ^{(2) (3)}	X	1	X	n/a	n/a
P6.5/CB5/A5	5	P6.5 (I/O)	I: 0; O: 1	0	0	n/a	n/a
		CB5	X	X	1	n/a	n/a
		A5 ^{(1) (2) (3)}	X	1	X	n/a	n/a
P6.6/CB6/A6/DAC0	6	P6.6 (I/O)	I: 0; O: 1	0	0	X	0
		CB6	X	X	1	X	0
		A6 ^{(2) (3)}	X	1	X	X	0
		DAC0	X	X	X	0	>1
P6.7/CB7/A7/DAC1	7	P6.7 (I/O)	I: 0; O: 1	0	0	X	0
		CB7	X	X	1	X	0
		A7 ^{(2) (3)}	X	1	X	X	0
		DAC1	X	X	X	0	>1

(1) X = Don't care

(2) Setting the P6SEL.x bit disables the output driver as well as the input Schmitt trigger to prevent parasitic cross currents when applying analog signals.

(3) The ADC12_A channel Ax is connected internally to AV_{SS} if not selected via the respective INCHx bits.

Port P7, P7.2, Input/Output With Schmitt Trigger

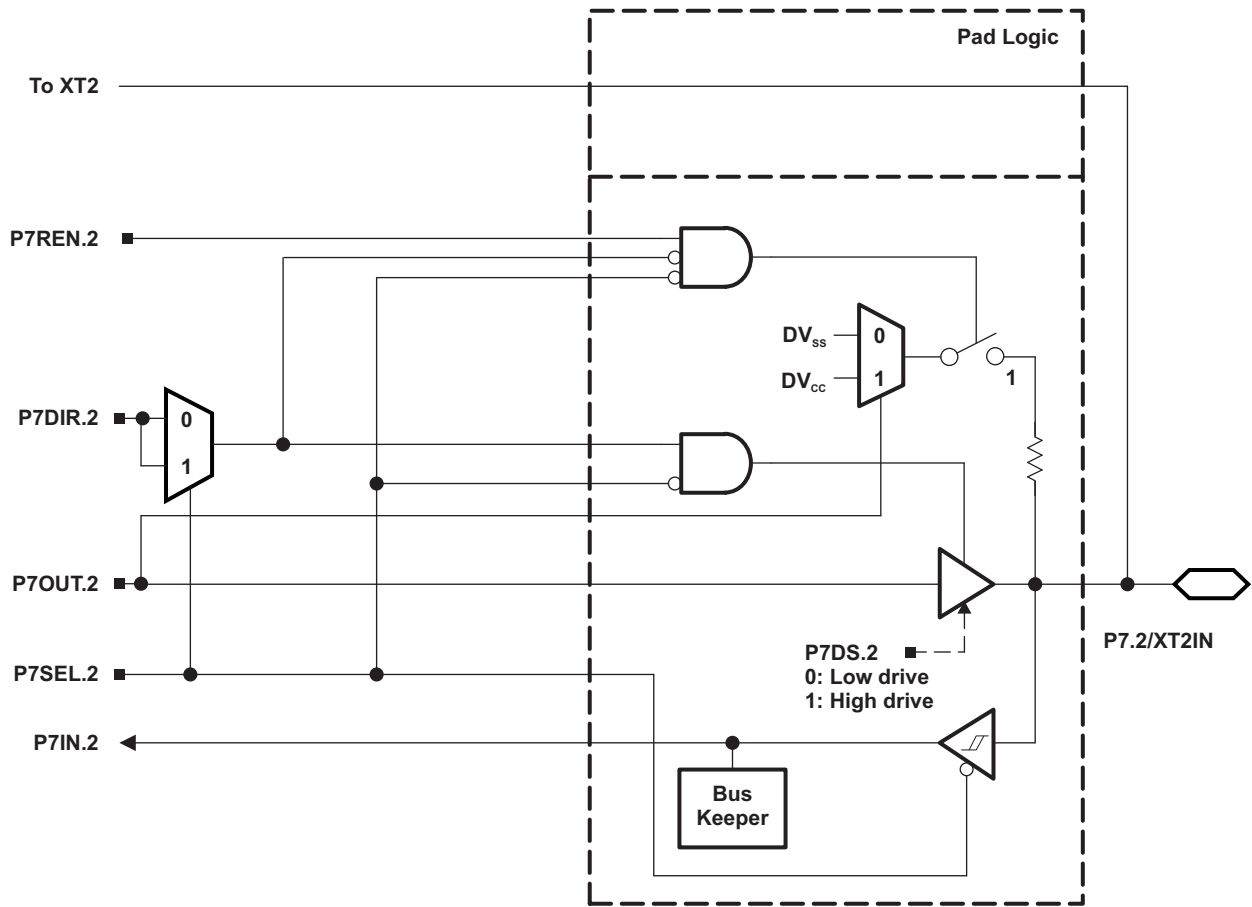

Port P7, P7.3, Input/Output With Schmitt Trigger

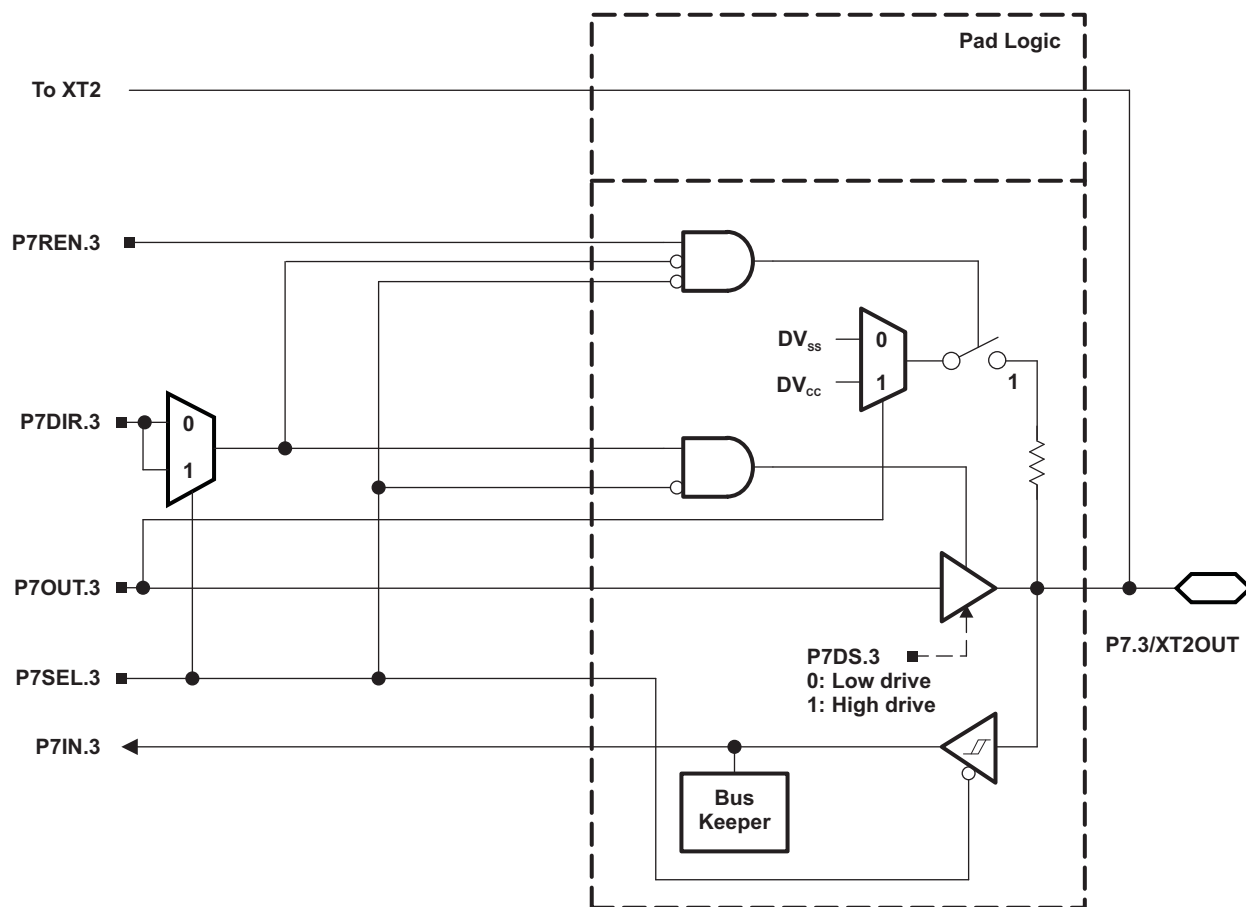

Table 62. Port P7 (P7.2 and P7.3) Pin Functions

PIN NAME (P5.x)	x	FUNCTION	CONTROL BITS/SIGNALS ⁽¹⁾			
			P7DIR.x	P7SEL.2	P7SEL.3	XT2BYPASS
P7.2/XT2IN	2	P7.2 (I/O)	I: 0; O: 1	0	X	X
		XT2IN crystal mode ⁽²⁾	X	1	X	0
		XT2IN bypass mode ⁽²⁾	X	1	X	1
P7.3/XT2OUT	3	P7.3 (I/O)	I: 0; O: 1	0	X	X
		XT2OUT crystal mode ⁽³⁾	X	1	X	0
		P7.3 (I/O) ⁽³⁾	X	1	X	1

(1) X = Don't care

(2) Setting P7SEL.2 causes the general-purpose I/O to be disabled. Pending the setting of XT2BYPASS, P7.2 is configured for crystal mode or bypass mode.

(3) Setting P7SEL.2 causes the general-purpose I/O to be disabled in crystal mode. When using bypass mode, P7.3 can be used as general-purpose I/O.

Port P7, P7.4 to P7.7, Input/Output With Schmitt Trigger

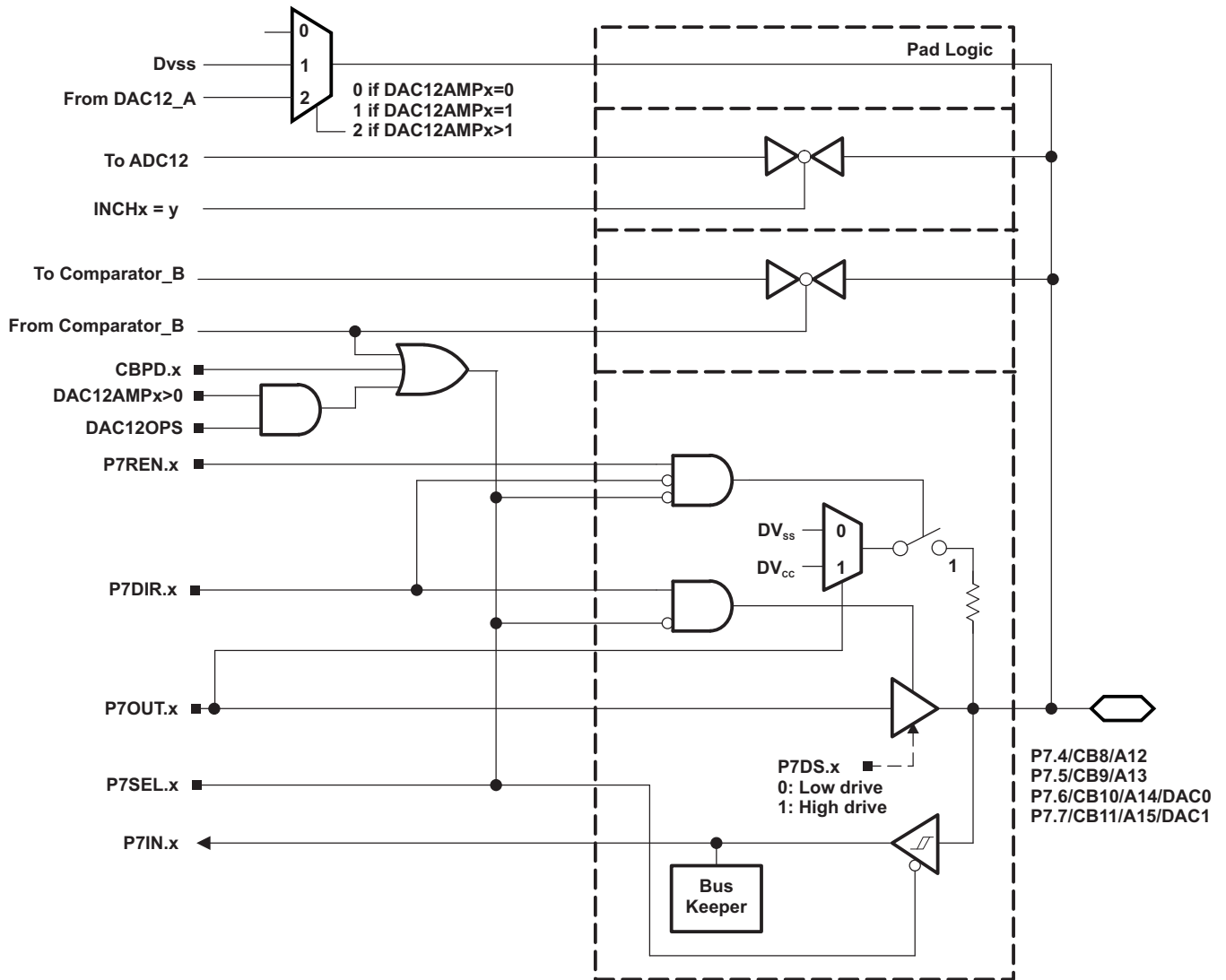

Table 63. Port P7 (P7.4 to P7.7) Pin Functions

PIN NAME (P7.x)	x	FUNCTION	CONTROL BITS/SIGNALS ⁽¹⁾				
			P7DIR.x	P7SEL.x	CBPD.x	DAC12OPS	DAC12AMPx
P7.4/CB8/A12	4	P7.4 (I/O)	I: 0; O: 1	0	0	n/a	n/a
		Comparator_B input CB8	X	X	1	n/a	n/a
		A12 ⁽²⁾ ⁽³⁾	X	1	X	n/a	n/a
P7.5/CB9/A13	5	P7.5 (I/O)	I: 0; O: 1	0	0	n/a	n/a
		Comparator_B input CB9	X	X	1	n/a	n/a
		A13 ⁽²⁾ ⁽³⁾	X	1	X	n/a	n/a
P7.6/CB10/A14/DAC0	6	P7.6 (I/O)	I: 0; O: 1	0	0	X	0
		Comparator_B input CB10	X	X	1	X	0
		A14 ⁽²⁾ ⁽³⁾	X	1	X	X	0
		DAC12_A output DAC0	X	X	X	1	>1
P7.7/CB11/A15/DAC1	7	P7.7 (I/O)	I: 0; O: 1	0	0	X	0
		Comparator_B input CB11	X	X	1	X	0
		A15 ⁽²⁾ ⁽³⁾	X	1	X	X	0
		DAC12_A output DAC1	X	X	X	1	>1

(1) X = Don't care

(2) Setting the P7SEL.x bit disables the output driver as well as the input Schmitt trigger to prevent parasitic cross currents when applying analog signals.

(3) The ADC12_A channel Ax is connected internally to AV_{SS} if not selected via the respective INCHx bits.

Port P8, P8.0 to P8.7, Input/Output With Schmitt Trigger

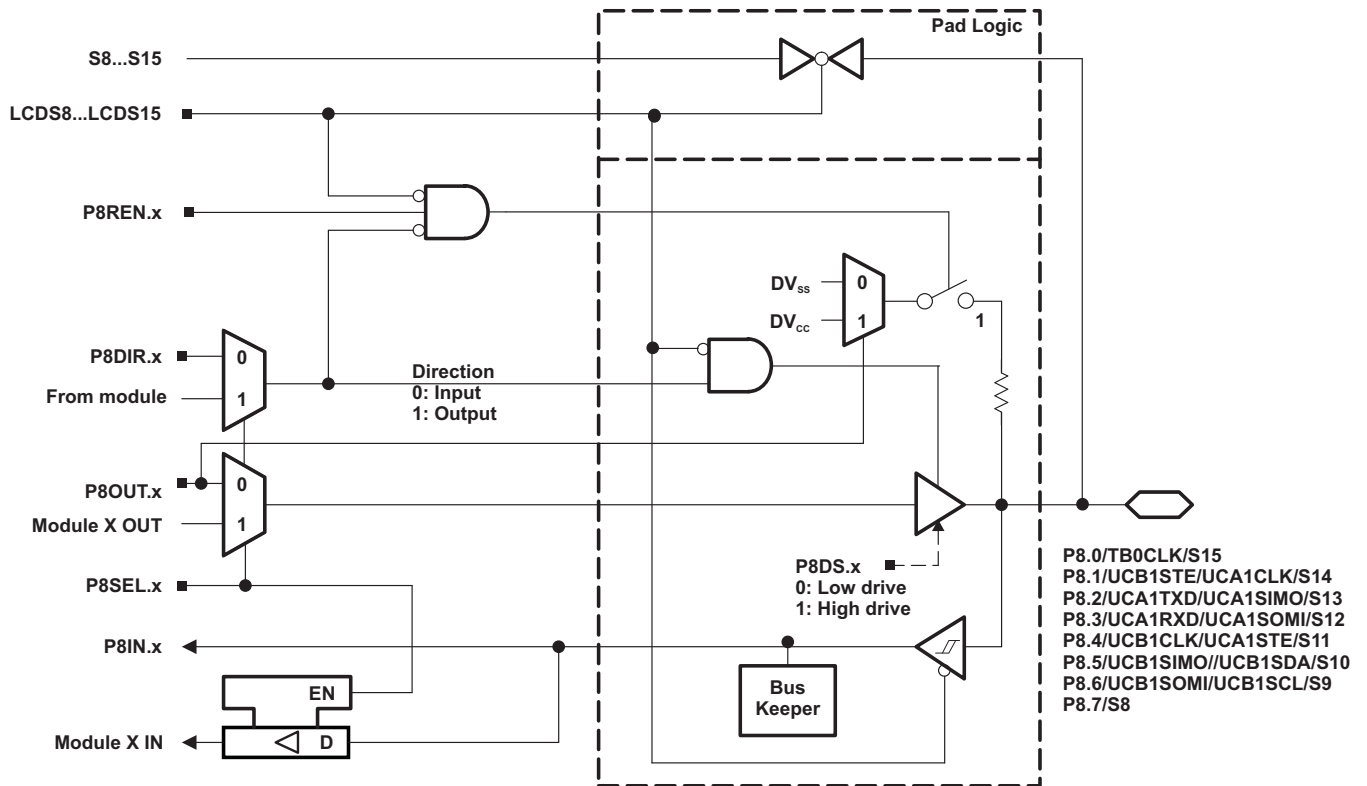

Table 64. Port P8 (P8.0 to P8.7) Pin Functions

PIN NAME (P9.x)	x	FUNCTION	CONTROL BITS/SIGNALS		
			P8DIR.x	P8SEL.x	LCDS8...16
P8.0/TB0CLK/S15	0	P8.0 (I/O)	I: 0; O: 1	0	0
		Timer TB0.TB0CLK clock input	0	1	0
		S15	X	X	1
P8.1/UCB1STE/UCA1CLK/S14	1	P8.1 (I/O)	I: 0; O: 1	0	0
		UCB1STE/UCA1CLK	X	1	0
		S14	X	X	1
P8.2/UCA1TXD/UCA1SIMO/S13	2	P8.2 (I/O)	I: 0; O: 1	0	0
		UCA1TXD/UCA1SIMO	X	1	0
		S13	X	X	1
P8.3/UCA1RXD/UCA1SOMI/S12	3	P8.3 (I/O)	I: 0; O: 1	0	0
		UCA1RXD/UCA1SOMI	X	1	0
		S12	X	X	1
P8.4/UCB1CLK/UCA1STE/S11	4	P8.4 (I/O)	I: 0; O: 1	0	0
		UCB1CLK/UCA1STE	X	1	0
		S11	X	X	1
P8.5/UCB1SIMO/UCB1SDA/S10	5	P8.5 (I/O)	I: 0; O: 1	0	0
		UCB1SIMO/UCB1SDA	X	1	0
		S10	X	X	1
P8.6/UCB1SOMI/UCB1SCL/S9	6	P8.6 (I/O)	I: 0; O: 1	0	0
		UCB1SOMI/UCB1SCL	X	1	0
		S9	X	X	1
P8.7/S8	7	P8.7 (I/O)	I: 0; O: 1	0	0
		S8	X	X	1

Port P9, P9.0 to P9.7, Input/Output With Schmitt Trigger

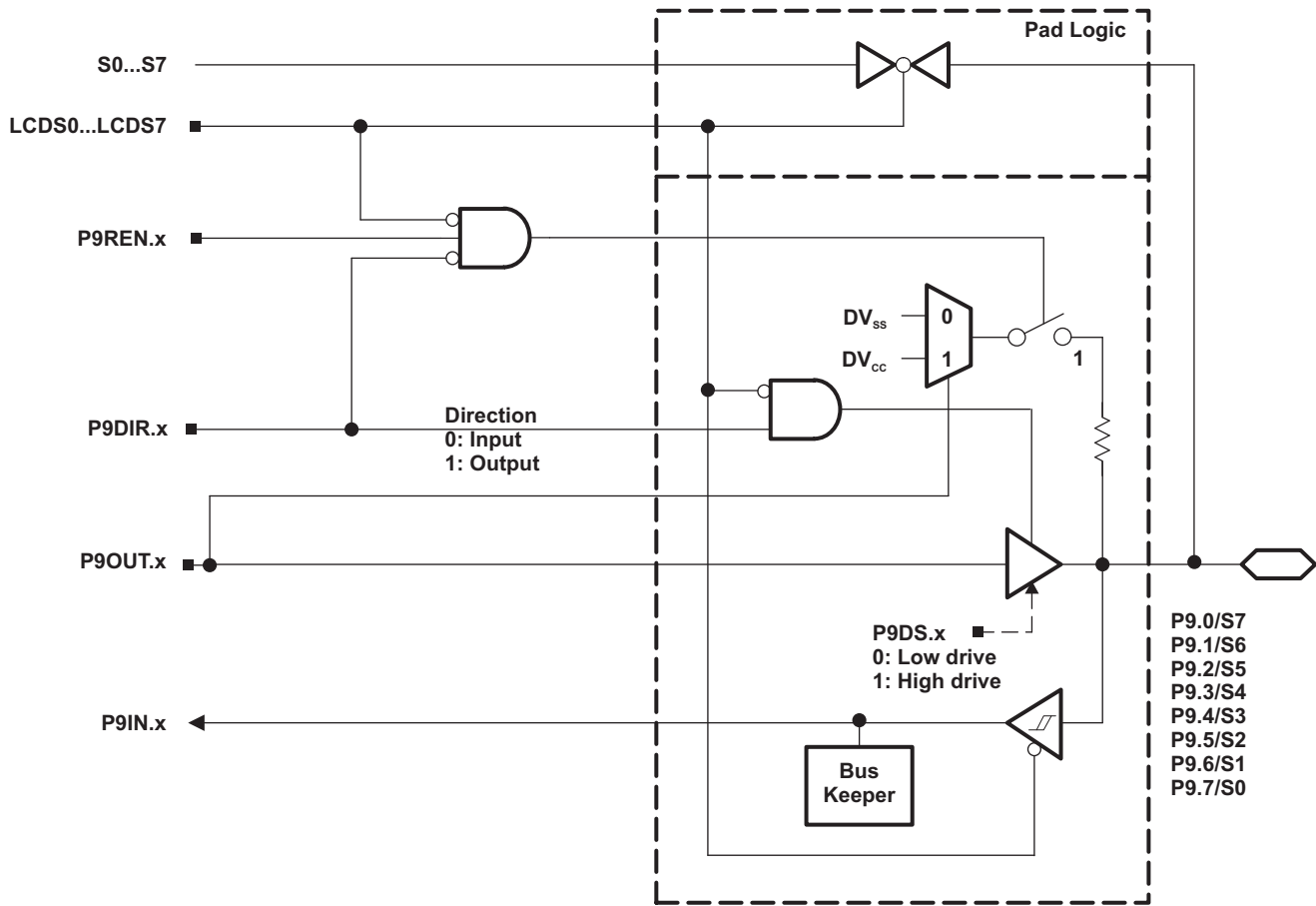

Table 65. Port P9 (P9.0 to P9.7) Pin Functions

PIN NAME (P9.x)	x	FUNCTION	CONTROL BITS/SIGNALS ⁽¹⁾		
			P9DIR.x	P9SEL.x	LCDS0...7
P9.0/S7	0	P9.0 (I/O)	I: 0; O: 1	0	0
		S7	X	X	1
P9.1/S6	1	P9.1 (I/O)	I: 0; O: 1	0	0
		S6	X	X	1
P9.2/S5	2	P9.2 (I/O)	I: 0; O: 1	0	0
		S5	X	X	1
P9.3/S4	3	P9.3 (I/O)	I: 0; O: 1	0	0
		S4	X	X	1
P9.4/S3	4	P9.4 (I/O)	I: 0; O: 1	0	0
		S3	X	X	1
P9.5/S2	5	P9.5 (I/O)	I: 0; O: 1	0	0
		S2	X	X	1
P9.6/S1	6	P9.6 (I/O)	I: 0; O: 1	0	0
		S1	X	X	1
P9.7/S0	7	P9.7 (I/O)	I: 0; O: 1	0	0
		S0	X	X	1

(1) X = Don't care

Port PU.0/DP, PU.1/DM, PUR USB Ports

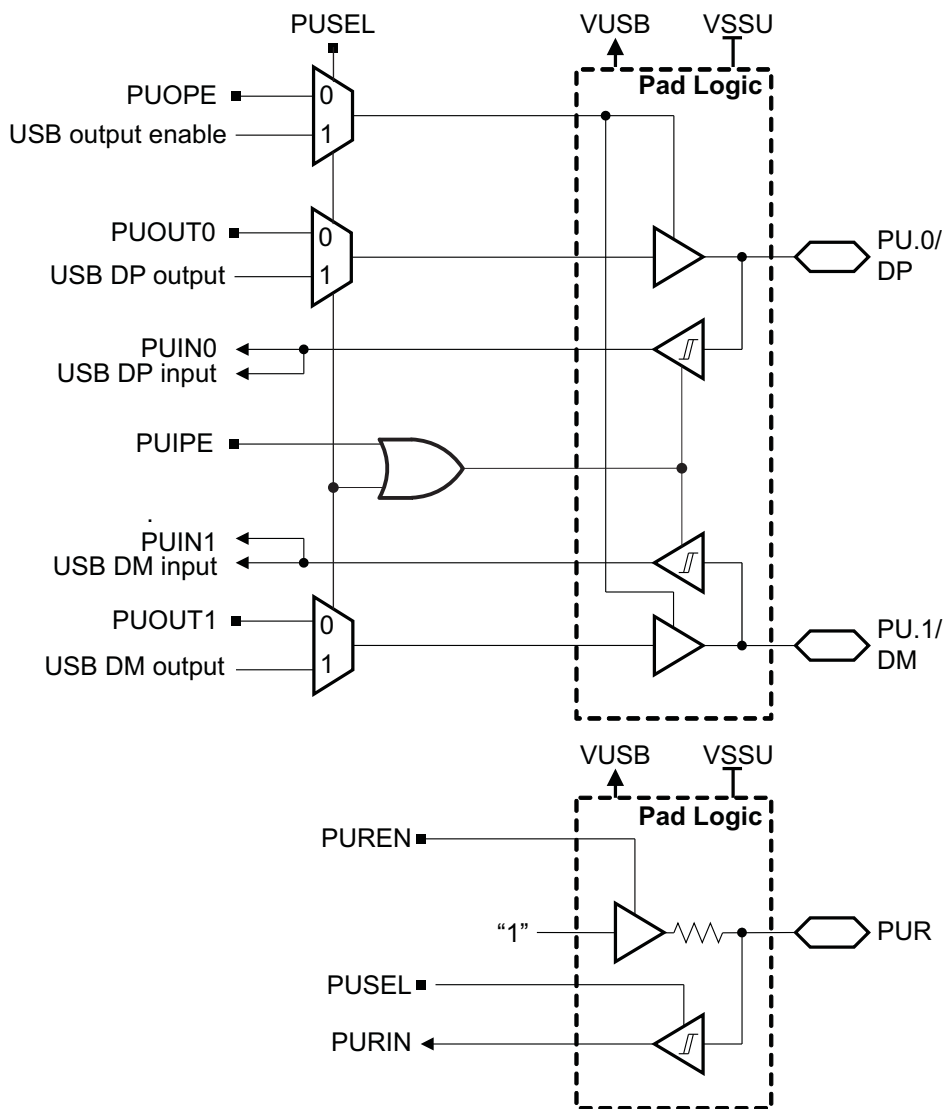

Table 66. Port PU.0/DP, PU.1/DM Output Functions

CONTROL BITS				PIN NAME		FUNCTION
PUSEL	PUDIR	PUOUT1	PUOUT0	PU.1/DM	PU.0/DP	
0	0	X	X	Hi-Z	Hi-Z	Outputs off
0	1	0	0	0	0	Outputs enabled
0	1	0	1	0	1	Outputs enabled
0	1	1	0	1	0	Outputs enabled
0	1	1	1	1	1	Outputs enabled
1	X	X	X	DM	DP	Direction set by USB module

Table 67. Port PUR Input Functions

CONTROL BITS		FUNCTION
PUSEL	PUREN	
0	0	Input disabled Pull up disabled
0	1	Input disabled Pull up enabled
1	0	Input enabled Pull up disabled
1	1	Input enabled Pull up enabled

Port J, J.0 JTAG pin TDO, Input/Output With Schmitt Trigger or Output

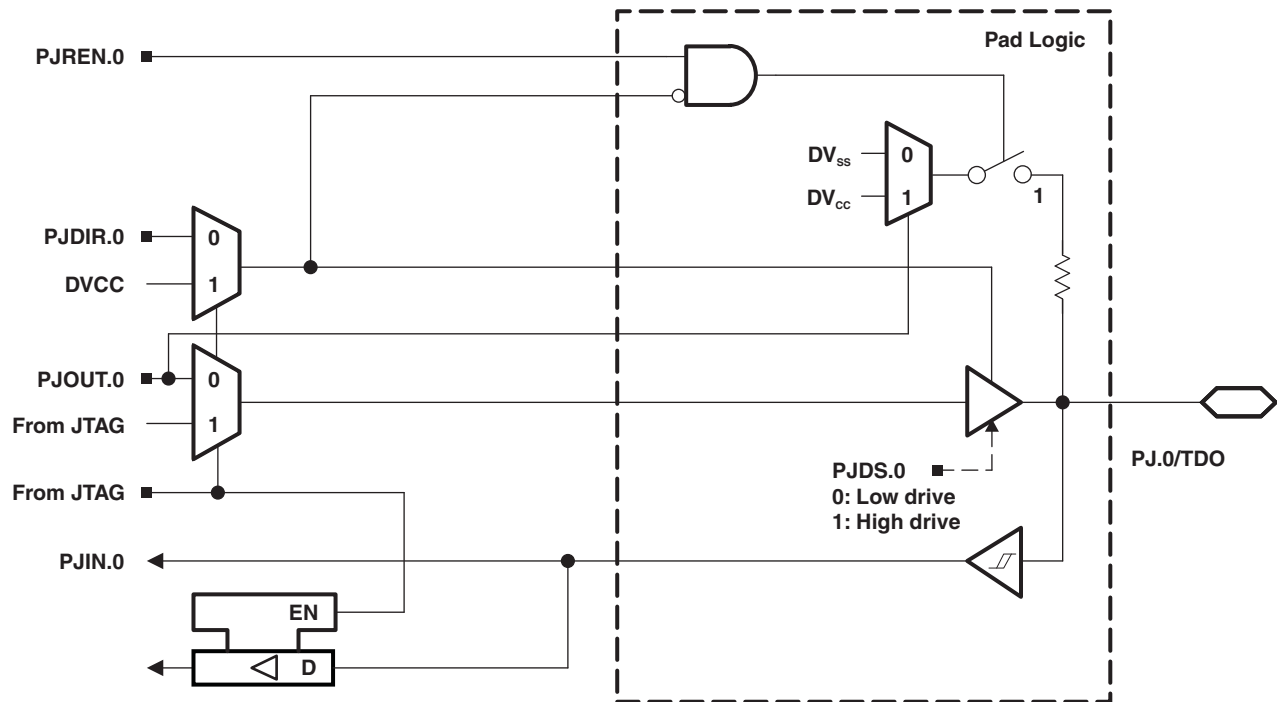

Port J, J.1 to J.3 JTAG pins TMS, TCK, TDI/TCLK, Input/Output With Schmitt Trigger or Output

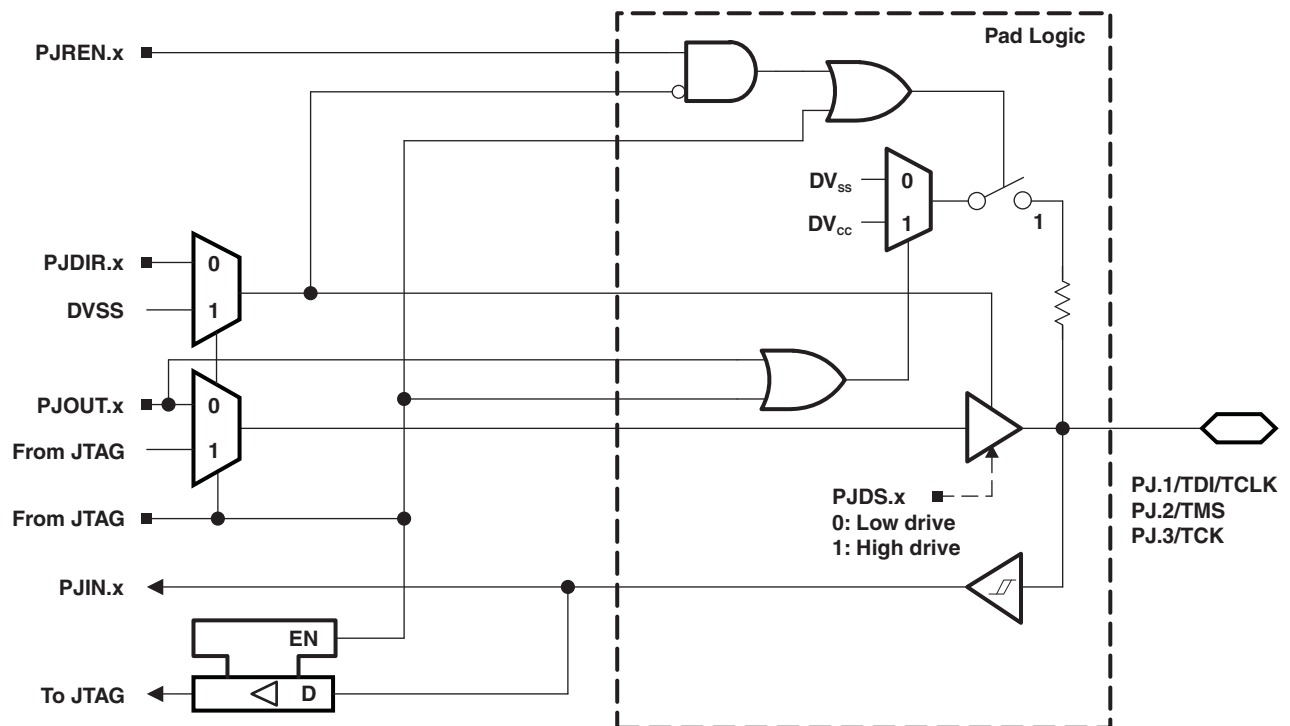

Table 68. Port PJ (PJ.0 to PJ.3) Pin Functions

PIN NAME (PJ.x)	x	FUNCTION	CONTROL BITS/ SIGNALS ⁽¹⁾
			PJDIR.x
PJ.0/TDO	0	PJ.0 (I/O) ⁽²⁾	I: 0; O: 1
		TDO ⁽³⁾	X
PJ.1/TDI/TCLK	1	PJ.1 (I/O) ⁽²⁾	I: 0; O: 1
		TDI/TCLK ^{(3) (4)}	X
PJ.2/TMS	2	PJ.2 (I/O) ⁽²⁾	I: 0; O: 1
		TMS ^{(3) (4)}	X
PJ.3/TCK	3	PJ.3 (I/O) ⁽²⁾	I: 0; O: 1
		TCK ^{(3) (4)}	X

(1) X = Don't care

(2) Default condition

(3) The pin direction is controlled by the JTAG module.

(4) In JTAG mode, pullups are activated automatically on TMS, TCK, and TDI/TCLK. PJREN.x are do not care.

DEVICE DESCRIPTORS

Table 69 list the complete contents of the device descriptor tag-length-value (TLV) structure for each device type.

Table 69. 'F663x Device Descriptor Table⁽¹⁾

	Description	Address	Size bytes	'F6638	'F6637	'F6636	'F6635	'F6634	'F6633	'F6632	'F6631	'F6630
				Value	Value	Value	Value	Value	Value	Value	Value	Value
Info Block	Info length	01A00h	1	06h	06h	06h	06h	06h	06h	06h	06h	06h
	CRC length	01A01h	1	06h	06h	06h	06h	06h	06h	06h	06h	06h
	CRC value	01A02h	2	per unit	per unit	per unit	per unit	per unit	per unit	per unit	per unit	per unit
	Device ID	01A04h	2	801Ch	801Ah	8018h	8016h	804Eh	804Ch	804Ah	8048h	8046h
	Hardware revision	01A06h	1	per unit	per unit	per unit	per unit	per unit	per unit	per unit	per unit	per unit
	Firmware revision	01A07h	1	per unit	per unit	per unit	per unit	per unit	per unit	per unit	per unit	per unit
	Die Record	Die Record Tag	01A08h	1	08h	08h	08h	08h	08h	08h	08h	08h
	Die Record length	01A09h	1	0Ah	0Ah	0Ah	0Ah	0Ah	0Ah	0Ah	0Ah	0Ah
	Lot/Wafer ID	01A0Ah	4	per unit	per unit	per unit	per unit	per unit	per unit	per unit	per unit	per unit
	Die X position	01A0Eh	2	per unit	per unit	per unit	per unit	per unit	per unit	per unit	per unit	per unit
	Die Y position	01A10h	2	per unit	per unit	per unit	per unit	per unit	per unit	per unit	per unit	per unit
	Test results	01A12h	2	per unit	per unit	per unit	per unit	per unit	per unit	per unit	per unit	per unit
ADC12 Calibration	ADC12 Calibration Tag	01A14h	1	11h	11h	11h	11h	11h	11h	05h	05h	05h
	ADC12 Calibration length	01A15h	1	10h	10h	10h	10h	10h	10h	10h	10h	10h
	ADC Gain Factor	01A16h	2	per unit	per unit	per unit	per unit	per unit	per unit	N/A	N/A	N/A
	ADC Offset	01A18h	2	per unit	per unit	per unit	per unit	per unit	per unit	N/A	N/A	N/A
	ADC 1.5-V Reference Temp. Sensor 30°C	01A1Ah	2	per unit	per unit	per unit	per unit	per unit	per unit	N/A	N/A	N/A
	ADC 1.5-V Reference Temp. Sensor 85°C	01A1Ch	2	per unit	per unit	per unit	per unit	per unit	per unit	N/A	N/A	N/A
	ADC 2.0-V Reference Temp. Sensor 30°C	01A1Eh	2	per unit	per unit	per unit	per unit	per unit	per unit	N/A	N/A	N/A
	ADC 2.0-V Reference Temp. Sensor 85°C	01A20h	2	per unit	per unit	per unit	per unit	per unit	per unit	N/A	N/A	N/A
	ADC 2.5-V Reference Temp. Sensor 30°C	01A22h	2	per unit	per unit	per unit	per unit	per unit	per unit	N/A	N/A	N/A
ADC 2.5-V Reference Temp. Sensor 85°C	01A24h	2	per unit	per unit	per unit	per unit	per unit	per unit	N/A	N/A	N/A	

(1) NA = Not applicable

REVISION HISTORY

REVISION	COMMENTS
SLAS566	Product Preview release
SLAS566A	Updated Product Preview including electrical specifications
SLAS566B	Production Data release

PACKAGING INFORMATION

Orderable Device	Status ⁽¹⁾	Package Type	Package Drawing	Pins	Package Qty	Eco Plan ⁽²⁾	Lead/ Ball Finish	MSL Peak Temp ⁽³⁾	Samples (Requires Login)
MSP430F6630IPZ	ACTIVE	LQFP	PZ	100	90	Green (RoHS & no Sb/Br)	CU NIPDAU	Level-3-260C-168 HR	
MSP430F6630IPZR	ACTIVE	LQFP	PZ	100	1000	Green (RoHS & no Sb/Br)	CU NIPDAU	Level-3-260C-168 HR	
MSP430F6630IZQWR	ACTIVE	BGA MICROSTAR JUNIOR	ZQW	113	2500	Green (RoHS & no Sb/Br)	SNAGCU	Level-3-260C-168 HR	
MSP430F6630ZQWT	ACTIVE	BGA MICROSTAR JUNIOR	ZQW	100		TBD	Call TI	Call TI	
MSP430F6631IPZ	ACTIVE	LQFP	PZ	100	90	Green (RoHS & no Sb/Br)	CU NIPDAU	Level-3-260C-168 HR	
MSP430F6631IPZR	ACTIVE	LQFP	PZ	100	1000	Green (RoHS & no Sb/Br)	CU NIPDAU	Level-3-260C-168 HR	
MSP430F6631IZQWR	ACTIVE	BGA MICROSTAR JUNIOR	ZQW	113	2500	Green (RoHS & no Sb/Br)	SNAGCU	Level-3-260C-168 HR	
MSP430F6631ZQWT	ACTIVE	BGA MICROSTAR JUNIOR	ZQW	100		TBD	Call TI	Call TI	
MSP430F6632IPZ	ACTIVE	LQFP	PZ	100	90	Green (RoHS & no Sb/Br)	CU NIPDAU	Level-3-260C-168 HR	
MSP430F6632IPZR	ACTIVE	LQFP	PZ	100	1000	Green (RoHS & no Sb/Br)	CU NIPDAU	Level-3-260C-168 HR	
MSP430F6632IZQWR	ACTIVE	BGA MICROSTAR JUNIOR	ZQW	113	2500	Green (RoHS & no Sb/Br)	SNAGCU	Level-3-260C-168 HR	
MSP430F6632ZQWT	ACTIVE	BGA MICROSTAR JUNIOR	ZQW	100		TBD	Call TI	Call TI	
MSP430F6633IPZ	ACTIVE	LQFP	PZ	100	90	Green (RoHS & no Sb/Br)	CU NIPDAU	Level-3-260C-168 HR	
MSP430F6633IPZR	ACTIVE	LQFP	PZ	100	1000	Green (RoHS & no Sb/Br)	CU NIPDAU	Level-3-260C-168 HR	

Orderable Device	Status ⁽¹⁾	Package Type	Package Drawing	Pins	Package Qty	Eco Plan ⁽²⁾	Lead/ Ball Finish	MSL Peak Temp ⁽³⁾	Samples (Requires Login)
MSP430F6633IZQWR	ACTIVE	BGA MICROSTAR JUNIOR	ZQW	113	2500	Green (RoHS & no Sb/Br)	SNAGCU	Level-3-260C-168 HR	
MSP430F6633ZQWT	ACTIVE	BGA MICROSTAR JUNIOR	ZQW	100		TBD	Call TI	Call TI	
MSP430F6634IPZ	ACTIVE	LQFP	PZ	100	90	Green (RoHS & no Sb/Br)	CU NIPDAU	Level-3-260C-168 HR	
MSP430F6634IPZR	ACTIVE	LQFP	PZ	100	1000	Green (RoHS & no Sb/Br)	CU NIPDAU	Level-3-260C-168 HR	
MSP430F6634IZQWR	ACTIVE	BGA MICROSTAR JUNIOR	ZQW	113	2500	Green (RoHS & no Sb/Br)	SNAGCU	Level-3-260C-168 HR	
MSP430F6634ZQWT	ACTIVE	BGA MICROSTAR JUNIOR	ZQW	100		TBD	Call TI	Call TI	
MSP430F6635IPZ	ACTIVE	LQFP	PZ	100	90	Green (RoHS & no Sb/Br)	CU NIPDAU	Level-3-260C-168 HR	
MSP430F6635IPZR	ACTIVE	LQFP	PZ	100	1000	Green (RoHS & no Sb/Br)	CU NIPDAU	Level-3-260C-168 HR	
MSP430F6635IZQWR	ACTIVE	BGA MICROSTAR JUNIOR	ZQW	113	2500	Green (RoHS & no Sb/Br)	SNAGCU	Level-3-260C-168 HR	
MSP430F6635ZQWT	ACTIVE	BGA MICROSTAR JUNIOR	ZQW	100		TBD	Call TI	Call TI	
MSP430F6636IPZ	ACTIVE	LQFP	PZ	100	90	Green (RoHS & no Sb/Br)	CU NIPDAU	Level-3-260C-168 HR	
MSP430F6636IPZR	ACTIVE	LQFP	PZ	100	1000	Green (RoHS & no Sb/Br)	CU NIPDAU	Level-3-260C-168 HR	
MSP430F6636IZQWR	ACTIVE	BGA MICROSTAR JUNIOR	ZQW	113	2500	Green (RoHS & no Sb/Br)	SNAGCU	Level-3-260C-168 HR	
MSP430F6636ZQWT	ACTIVE	BGA MICROSTAR JUNIOR	ZQW	100		TBD	Call TI	Call TI	

Orderable Device	Status ⁽¹⁾	Package Type	Package Drawing	Pins	Package Qty	Eco Plan ⁽²⁾	Lead/ Ball Finish	MSL Peak Temp ⁽³⁾	Samples (Requires Login)
MSP430F6637IPZ	ACTIVE	LQFP	PZ	100	90	Green (RoHS & no Sb/Br)	CU NIPDAU	Level-3-260C-168 HR	
MSP430F6637IPZR	ACTIVE	LQFP	PZ	100	1000	Green (RoHS & no Sb/Br)	CU NIPDAU	Level-3-260C-168 HR	
MSP430F6637IZQWR	ACTIVE	BGA MICROSTAR JUNIOR	ZQW	113	2500	Green (RoHS & no Sb/Br)	SNAGCU	Level-3-260C-168 HR	
MSP430F6637IZQWT	ACTIVE	BGA MICROSTAR JUNIOR	ZQW	113	250	Green (RoHS & no Sb/Br)	SNAGCU	Level-3-260C-168 HR	
MSP430F6638CY	ACTIVE					Green (RoHS & no Sb/Br)	Call TI	N / A for Pkg Type	
MSP430F6638CYS	ACTIVE	WAFERSALE	YS	0	1	TBD	Call TI	Call TI	
MSP430F6638IPZ	ACTIVE	LQFP	PZ	100	90	Green (RoHS & no Sb/Br)	CU NIPDAU	Level-3-260C-168 HR	
MSP430F6638IPZR	ACTIVE	LQFP	PZ	100	1000	Green (RoHS & no Sb/Br)	CU NIPDAU	Level-3-260C-168 HR	
MSP430F6638IZQWR	ACTIVE	BGA MICROSTAR JUNIOR	ZQW	113	2500	Green (RoHS & no Sb/Br)	SNAGCU	Level-3-260C-168 HR	
MSP430F6638IZQWT	ACTIVE	BGA MICROSTAR JUNIOR	ZQW	113	250	Green (RoHS & no Sb/Br)	SNAGCU	Level-3-260C-168 HR	

⁽¹⁾ The marketing status values are defined as follows:

ACTIVE: Product device recommended for new designs.

LIFEBUY: TI has announced that the device will be discontinued, and a lifetime-buy period is in effect.

NRND: Not recommended for new designs. Device is in production to support existing customers, but TI does not recommend using this part in a new design.

PREVIEW: Device has been announced but is not in production. Samples may or may not be available.

OBSELETE: TI has discontinued the production of the device.

⁽²⁾ Eco Plan - The planned eco-friendly classification: Pb-Free (RoHS), Pb-Free (RoHS Exempt), or Green (RoHS & no Sb/Br) - please check <http://www.ti.com/productcontent> for the latest availability information and additional product content details.

TBD: The Pb-Free/Green conversion plan has not been defined.

Pb-Free (RoHS): TI's terms "Lead-Free" or "Pb-Free" mean semiconductor products that are compatible with the current RoHS requirements for all 6 substances, including the requirement that lead not exceed 0.1% by weight in homogeneous materials. Where designed to be soldered at high temperatures, TI Pb-Free products are suitable for use in specified lead-free processes.

Pb-Free (RoHS Exempt): This component has a RoHS exemption for either 1) lead-based flip-chip solder bumps used between the die and package, or 2) lead-based die adhesive used between the die and leadframe. The component is otherwise considered Pb-Free (RoHS compatible) as defined above.

Green (RoHS & no Sb/Br): TI defines "Green" to mean Pb-Free (RoHS compatible), and free of Bromine (Br) and Antimony (Sb) based flame retardants (Br or Sb do not exceed 0.1% by weight in homogeneous material)

⁽³⁾ MSL, Peak Temp. -- The Moisture Sensitivity Level rating according to the JEDEC industry standard classifications, and peak solder temperature.

Important Information and Disclaimer: The information provided on this page represents TI's knowledge and belief as of the date that it is provided. TI bases its knowledge and belief on information provided by third parties, and makes no representation or warranty as to the accuracy of such information. Efforts are underway to better integrate information from third parties. TI has taken and continues to take reasonable steps to provide representative and accurate information but may not have conducted destructive testing or chemical analysis on incoming materials and chemicals. TI and TI suppliers consider certain information to be proprietary, and thus CAS numbers and other limited information may not be available for release.

In no event shall TI's liability arising out of such information exceed the total purchase price of the TI part(s) at issue in this document sold by TI to Customer on an annual basis.

TAPE AND REEL INFORMATION

REEL DIMENSIONS

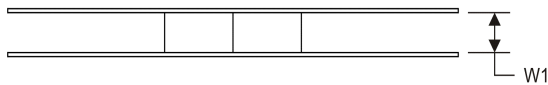
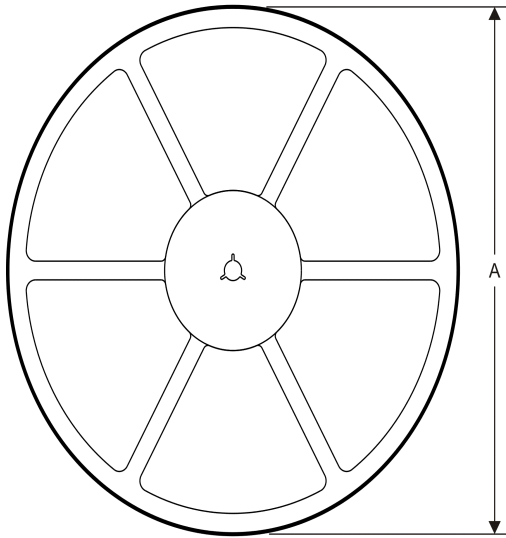

TAPE DIMENSIONS

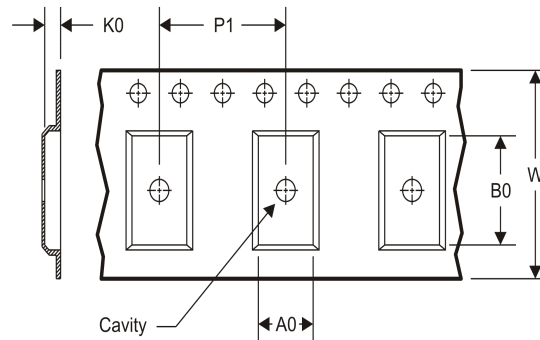

A0	Dimension designed to accommodate the component width
B0	Dimension designed to accommodate the component length
K0	Dimension designed to accommodate the component thickness
W	Overall width of the carrier tape
P1	Pitch between successive cavity centers

TAPE AND REEL INFORMATION

*All dimensions are nominal

Device	Package Type	Package Drawing	Pins	SPQ	Reel Diameter (mm)	Reel Width W1 (mm)	A0 (mm)	B0 (mm)	K0 (mm)	P1 (mm)	W (mm)	Pin1 Quadrant
MSP430F6632IPZR	LQFP	PZ	100	1000	330.0	24.4	17.4	17.4	2.0	20.0	24.0	Q2
MSP430F6633IPZR	LQFP	PZ	100	1000	330.0	24.4	17.4	17.4	2.0	20.0	24.0	Q2
MSP430F6633IZQWR	BGA MICROSTAR JUNIOR	ZQW	113	2500	330.0	16.4	7.3	7.3	1.5	12.0	16.0	Q1
MSP430F6635IPZR	LQFP	PZ	100	1000	330.0	24.4	17.4	17.4	2.0	20.0	24.0	Q2
MSP430F6635IZQWR	BGA MICROSTAR JUNIOR	ZQW	113	2500	330.0	16.4	7.3	7.3	1.5	12.0	16.0	Q1
MSP430F6636IZQWR	BGA MICROSTAR JUNIOR	ZQW	113	2500	330.0	16.4	7.3	7.3	1.5	12.0	16.0	Q1
MSP430F6637IZQWT	BGA MICROSTAR JUNIOR	ZQW	113	250	330.0	16.4	7.3	7.3	1.5	12.0	16.0	Q1
MSP430F6638IPZR	LQFP	PZ	100	1000	330.0	24.4	17.4	17.4	2.0	20.0	24.0	Q2
MSP430F6638IZQWR	BGA MICROSTAR	ZQW	113	2500	330.0	16.4	7.3	7.3	1.5	12.0	16.0	Q1

Device	Package Type	Package Drawing	Pins	SPQ	Reel Diameter (mm)	Reel Width W1 (mm)	A0 (mm)	B0 (mm)	K0 (mm)	P1 (mm)	W (mm)	Pin1 Quadrant
	R JUNIOR											
MSP430F6638IZQWT	BGA MICROSTAR JUNIOR	ZQW	113	250	330.0	16.4	7.3	7.3	1.5	12.0	16.0	Q1

TAPE AND REEL BOX DIMENSIONS

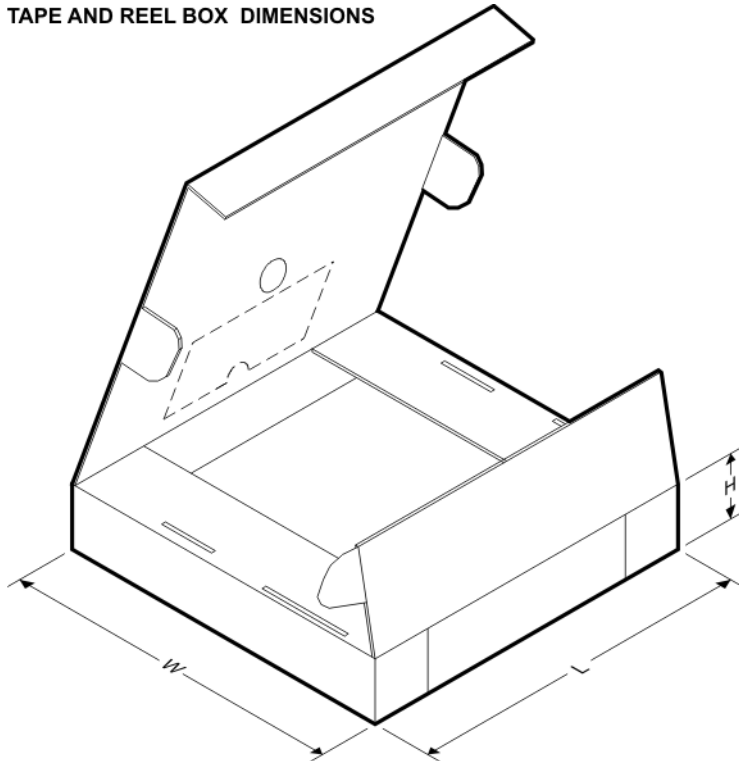

*All dimensions are nominal

Device	Package Type	Package Drawing	Pins	SPQ	Length (mm)	Width (mm)	Height (mm)
MSP430F6632IPZR	LQFP	PZ	100	1000	346.0	346.0	41.0
MSP430F6633IPZR	LQFP	PZ	100	1000	346.0	346.0	41.0
MSP430F6633IZQWR	BGA MICROSTAR JUNIOR	ZQW	113	2500	336.6	336.6	28.6
MSP430F6635IPZR	LQFP	PZ	100	1000	346.0	346.0	41.0
MSP430F6635IZQWR	BGA MICROSTAR JUNIOR	ZQW	113	2500	336.6	336.6	28.6
MSP430F6636IZQWR	BGA MICROSTAR JUNIOR	ZQW	113	2500	336.6	336.6	28.6
MSP430F6637IZQWT	BGA MICROSTAR JUNIOR	ZQW	113	250	336.6	336.6	28.6
MSP430F6638IPZR	LQFP	PZ	100	1000	346.0	346.0	41.0
MSP430F6638IZQWR	BGA MICROSTAR	ZQW	113	2500	336.6	336.6	28.6

Device	Package Type	Package Drawing	Pins	SPQ	Length (mm)	Width (mm)	Height (mm)
	JUNIOR						
MSP430F6638IZQWT	BGA MICROSTAR JUNIOR	ZQW	113	250	336.6	336.6	28.6

ZQW (S-PBGA-N113)

PLASTIC BALL GRID ARRAY

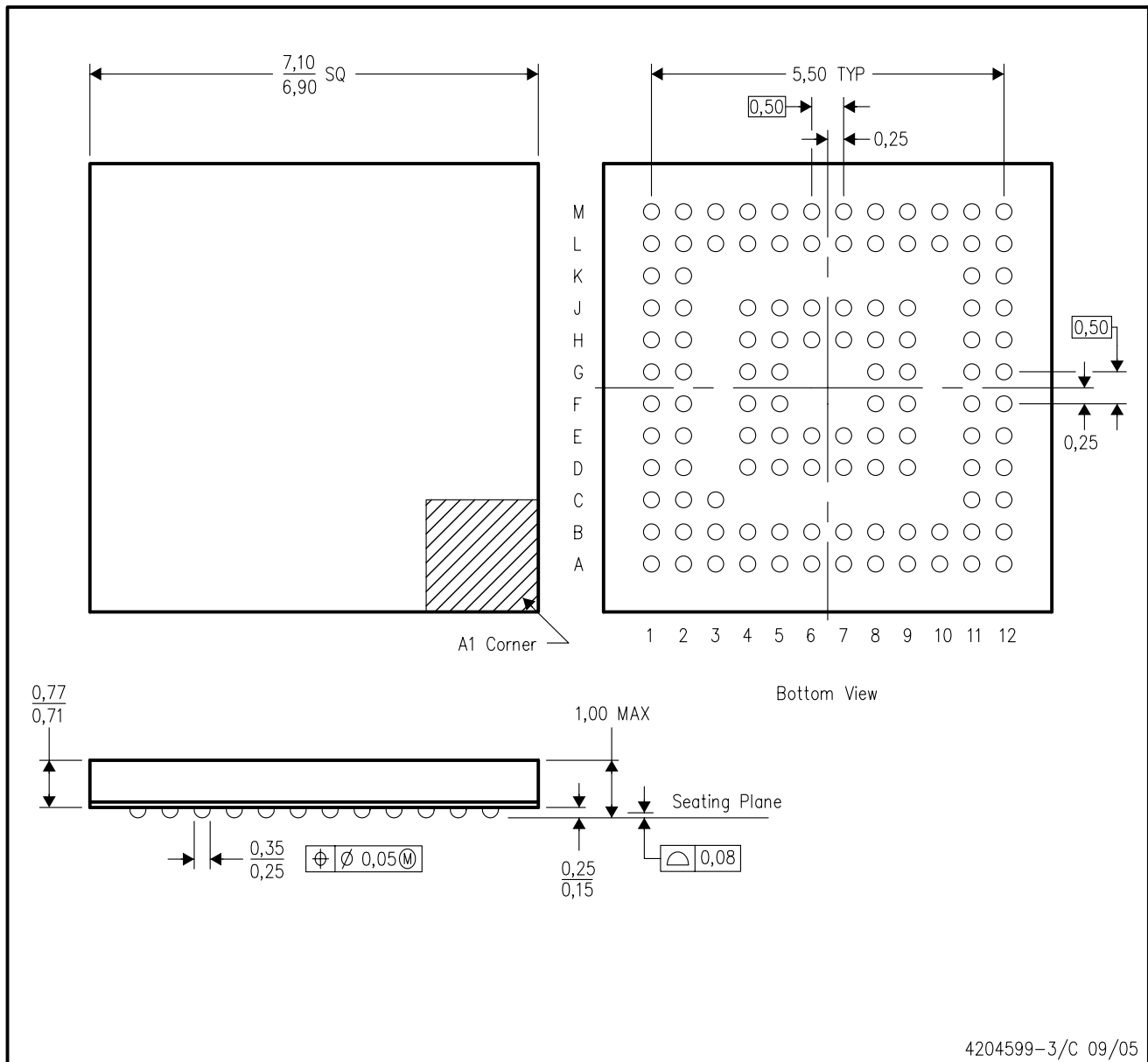

- NOTES:
- A. All linear dimensions are in millimeters.
 - B. This drawing is subject to change without notice.
 - C. Falls within JEDEC MO-225
 - D. This is a lead-free solder ball design.

PZ (S-PQFP-G100)

PLASTIC QUAD FLATPACK

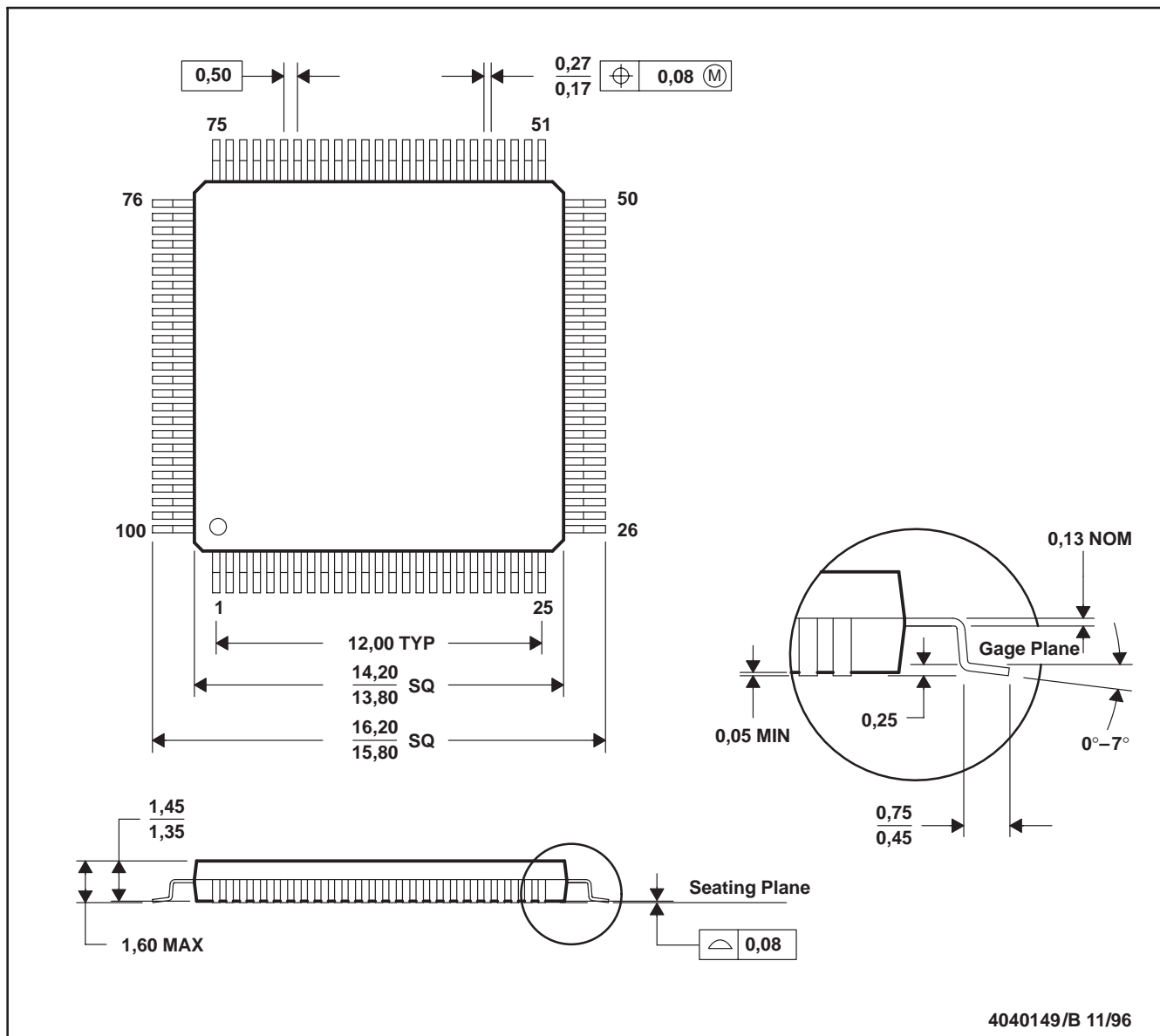

- NOTES: A. All linear dimensions are in millimeters.
 B. This drawing is subject to change without notice.
 C. Falls within JEDEC MS-026

IMPORTANT NOTICE

Texas Instruments Incorporated and its subsidiaries (TI) reserve the right to make corrections, modifications, enhancements, improvements, and other changes to its products and services at any time and to discontinue any product or service without notice. Customers should obtain the latest relevant information before placing orders and should verify that such information is current and complete. All products are sold subject to TI's terms and conditions of sale supplied at the time of order acknowledgment.

TI warrants performance of its hardware products to the specifications applicable at the time of sale in accordance with TI's standard warranty. Testing and other quality control techniques are used to the extent TI deems necessary to support this warranty. Except where mandated by government requirements, testing of all parameters of each product is not necessarily performed.

TI assumes no liability for applications assistance or customer product design. Customers are responsible for their products and applications using TI components. To minimize the risks associated with customer products and applications, customers should provide adequate design and operating safeguards.

TI does not warrant or represent that any license, either express or implied, is granted under any TI patent right, copyright, mask work right, or other TI intellectual property right relating to any combination, machine, or process in which TI products or services are used. Information published by TI regarding third-party products or services does not constitute a license from TI to use such products or services or a warranty or endorsement thereof. Use of such information may require a license from a third party under the patents or other intellectual property of the third party, or a license from TI under the patents or other intellectual property of TI.

Reproduction of TI information in TI data books or data sheets is permissible only if reproduction is without alteration and is accompanied by all associated warranties, conditions, limitations, and notices. Reproduction of this information with alteration is an unfair and deceptive business practice. TI is not responsible or liable for such altered documentation. Information of third parties may be subject to additional restrictions.

Resale of TI products or services with statements different from or beyond the parameters stated by TI for that product or service voids all express and any implied warranties for the associated TI product or service and is an unfair and deceptive business practice. TI is not responsible or liable for any such statements.

TI products are not authorized for use in safety-critical applications (such as life support) where a failure of the TI product would reasonably be expected to cause severe personal injury or death, unless officers of the parties have executed an agreement specifically governing such use. Buyers represent that they have all necessary expertise in the safety and regulatory ramifications of their applications, and acknowledge and agree that they are solely responsible for all legal, regulatory and safety-related requirements concerning their products and any use of TI products in such safety-critical applications, notwithstanding any applications-related information or support that may be provided by TI. Further, Buyers must fully indemnify TI and its representatives against any damages arising out of the use of TI products in such safety-critical applications.

TI products are neither designed nor intended for use in military/aerospace applications or environments unless the TI products are specifically designated by TI as military-grade or "enhanced plastic." Only products designated by TI as military-grade meet military specifications. Buyers acknowledge and agree that any such use of TI products which TI has not designated as military-grade is solely at the Buyer's risk, and that they are solely responsible for compliance with all legal and regulatory requirements in connection with such use.

TI products are neither designed nor intended for use in automotive applications or environments unless the specific TI products are designated by TI as compliant with ISO/TS 16949 requirements. Buyers acknowledge and agree that, if they use any non-designated products in automotive applications, TI will not be responsible for any failure to meet such requirements.

Following are URLs where you can obtain information on other Texas Instruments products and application solutions:

Products

Audio	www.ti.com/audio
Amplifiers	amplifier.ti.com
Data Converters	dataconverter.ti.com
DLP® Products	www.dlp.com
DSP	dsp.ti.com
Clocks and Timers	www.ti.com/clocks
Interface	interface.ti.com
Logic	logic.ti.com
Power Mgmt	power.ti.com
Microcontrollers	microcontroller.ti.com
RFID	www.ti-rfid.com
OMAP Mobile Processors	www.ti.com/omap
Wireless Connectivity	www.ti.com/wirelessconnectivity

Applications

Automotive and Transportation	www.ti.com/automotive
Communications and Telecom	www.ti.com/communications
Computers and Peripherals	www.ti.com/computers
Consumer Electronics	www.ti.com/consumer-apps
Energy and Lighting	www.ti.com/energy
Industrial	www.ti.com/industrial
Medical	www.ti.com/medical
Security	www.ti.com/security
Space, Avionics and Defense	www.ti.com/space-avionics-defense
Video and Imaging	www.ti.com/video

TI E2E Community Home Page

e2e.ti.com

Mailing Address: Texas Instruments, Post Office Box 655303, Dallas, Texas 75265
Copyright © 2012, Texas Instruments Incorporated