

TMP100-EP DIGITAL TEMPERATURE SENSOR WITH I²C INTERFACE

SGLS254B – JULY 2005 – REVISED OCTOBER 2013

- **Controlled Baseline**
 - One Assembly/Test Site, One Fabrication Site
- **Enhanced Diminishing Manufacturing Sources (DMS) Support**
- **Enhanced Product-Change Notification**
- **Qualification Pedigree[†]**
- **Digital Output: I²C Serial 2-Wire**
- **Resolution: 9- to 12-Bits, User Selectable**
- **Accuracy: ±2°C from –25°C to +85°C (MAX), ±3°C from –55°C to +125°C (MAX)**

[†] Component qualification in accordance with JEDEC and industry standards to ensure reliable operation over an extended temperature range. This includes, but is not limited to, Highly Accelerated Stress Test (HAST) or biased 85/85, temperature cycle, autoclave or unbiased HAST, electromigration, bond intermetallic life, and mold compound life. Such qualification testing should not be viewed as justifying use of this component beyond specified performance and environmental limits.

- **Low Quiescent Current: 45 µA, 0.1-µA Standby**
- **Wide Supply Range: 2.7 V to 5.5 V**
- **Small SOT23-6 Package**

applications

- **Power-Supply Temperature Monitoring**
- **Computer Peripheral Thermal Protection**
- **Notebook Computers**
- **Battery Management**
- **Thermostat Controls**
- **Environmental Monitoring**
- **Electromechanical Device Temperature**

description/ordering information

The TMP100 and TMP101 are 2-wire, serial output temperature sensors available in SOT23–6 packages. Requiring no external components, the TMP100 and TMP101 are capable of reading temperatures with a resolution of 0.0625°C.

The TMP100 and TMP101 feature SMBus and I²C™ interface compatibility, with the TMP100 allowing up to eight devices on one bus.

The TMP100 and TMP101 are ideal for extended temperature measurement in a variety of communication, computer, consumer, environmental, industrial, and instrumentation applications.

The TMP100M and TMP101M are specified for operation over a temperature range of –55°C to +125°C.

DBV PACKAGE
(TOP VIEW)

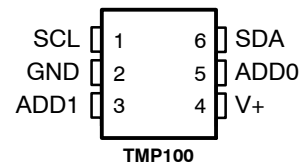

ORDERING INFORMATION

T _A	PACKAGE [†]	ORDERABLE PART NUMBER	TOP-SIDE MARKING
–55°C to 125°C	SOT23-6 (DBV) Reel of 3000	TMP100MDBVREP	100E

[†] Package drawings, standard packing quantities, thermal data, symbolization, and PCB design guidelines are available at www.ti.com/sc/package.

[‡] Product Preview



This integrated circuit can be damaged by ESD. Texas Instruments recommends that all integrated circuits be handled with appropriate precautions. Failure to observe proper handling and installation procedures can cause damage. ESD damage can range from subtle performance degradation to complete device failure. Precision integrated circuits may be more susceptible to damage because very small parametric changes could cause the device not to meet its published specifications. These devices have limited built-in ESD protection.



Please be aware that an important notice concerning availability, standard warranty, and use in critical applications of Texas Instruments semiconductor products and disclaimers thereto appears at the end of this data sheet.

I²C is a registered trademark of Philips Incorporated.

PRODUCTION DATA information is current as of publication date. Products conform to specifications per the terms of Texas Instruments standard warranty. Production processing does not necessarily include testing of all parameters.



POST OFFICE BOX 655303 • DALLAS, TEXAS 75265

Copyright © 2004 Texas Instruments Incorporated

TMP100-EP DIGITAL TEMPERATURE SENSOR WITH I²C INTERFACE

SGLS254B – JULY 2005 – REVISED OCTOBER 2013

functional block diagram

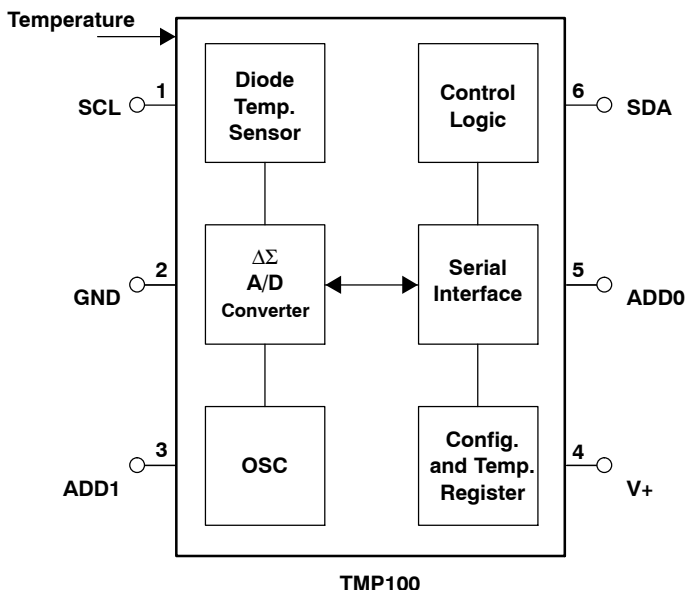

absolute maximum ratings over operating free-air temperature range (unless otherwise noted)[†]

Supply voltage, V+	7.5 V
Input voltage range	-0.5 V to 7.5 V
Operating free-air temperature range, T _A	-55°C to 125°C
Storage temperature range, T _{stg}	-60°C to 150°C
Maximum Junction temperature, T _J	150°C
Thermal impedance, θ _{JA} (See Note 1)	165°C/W
Lead temperature soldering	300°C

[†] Stresses beyond those listed under “absolute maximum ratings” may cause permanent damage to the device. These are stress ratings only, and functional operation of the device at these or any other conditions beyond those indicated under “recommended operating conditions” is not implied. Exposure to absolute-maximum-rated conditions for extended periods may affect device reliability.

NOTE 1: The thermal impedance, θ_{JA}, for the DBV package is determined for JEDEC high-K PCB (JESD 51-7).

recommended operating conditions

	MIN	NOM	MAX	UNIT
Supply voltage, V+	2.7		5.5	V
Operating free-air temperature, T _A	-55		125	°C

electrical characteristics over recommended operating free-air temperature range, V_{DD} = 2.7 V to 5.5 V (unless otherwise noted)

temperature input

PARAMETER	TEST CONDITIONS	MIN	TYP	MAX	UNIT
Range		-55		125	°C
Accuracy (temperature error)	-25°C to 85°C		±0.5	±2	°C
	-55°C to 125°C		±1	±3	
Resolution	Selectable		±0.0625		°C



POST OFFICE BOX 655303 • DALLAS, TEXAS 75265

TMP100-EP
DIGITAL TEMPERATURE SENSOR
WITH I²C INTERFACE

SGLS254B – JULY 2005 – REVISED OCTOBER 2013

digital input/output

PARAMETER		TEST CONDITIONS		MIN	TYP	MAX	UNIT
V _{IH}	High-level input voltage			0.7(V ₊)	(V ₊)	+ 0.5	V
V _{IL}	Low-level input voltage			-0.5		0.3(V ₊)	V
I _{IN}	Input current	V _{IN} = 0 V to 6 V				1	μA
V _{OL}	Low-level output voltage	I _{OL} = 3 mA	SDA	0	0.15	0.4	V
		I _{OL} = 4 mA	ALERT	0	0.15	0.4	
Resolution		Selectable		9 to 12			bits
	Conversion time	9-bit		40		75	ms
		10-bit		80		150	
		11-bit		160		300	
		12-bit		320		600	
	Conversion rate	9-bit		25			s/s
		10-bit		12			
		11-bit		6			
		12-bit		3			

power supply

PARAMETER		TEST CONDITIONS		MIN	TYP	MAX	UNIT
I _Q	Quiescent current	Serial bus inactive			45	75	μA
		Serial bus active	SCL = 400 kHz		70		
			SCL = 3.4 MHz		150		
I _{SD}	Shutdown current	Serial bus inactive			0.1	1	μA
		Serial bus active	SCL = 400 kHz		20		
			SCL = 3.4 MHz		100		



TMP100-EP DIGITAL TEMPERATURE SENSOR WITH I²C INTERFACE

SGLS254B – JULY 2005 – REVISED OCTOBER 2013

APPLICATION INFORMATION

The TMP100 and TMP101 are digital temperature sensors optimal for thermal management and thermal protection applications. The TMP100 and TMP101 are I²C and SMBus interface compatible and are specified over a temperature range of -55°C to +125°C.

The TMP100 and TMP101 require no external components for operation except for pullup resistors on SCL, SDA, and ALERT although a 0.1-μF bypass capacitor is recommended, as shown in Figure 1.

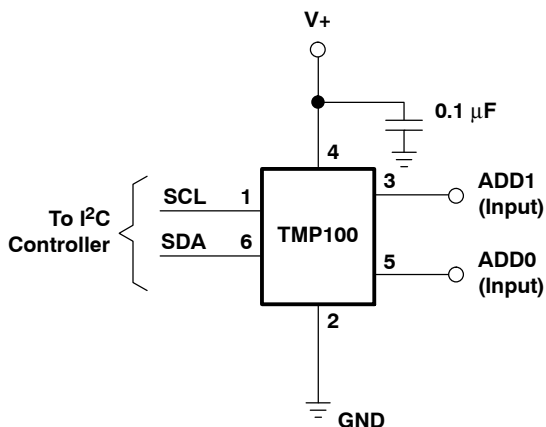

NOTE 2: SCL and SDA require pullup resistors for I²C bus applications.

Figure 1. Typical Connections of the TMP100

The die flag of the lead frame is connected to pin 2. The sensing device of the TMP100 and TMP101 is the chip itself. Thermal paths run through the package leads as well as the plastic package. The lower thermal resistance of metal causes the leads to provide the primary thermal path. The GND pin of the TMP100 or TMP101 is directly connected to the metal lead frame and is the best choice for thermal input.

To maintain the accuracy in applications requiring air or surface temperature measurement, care should be taken to isolate the package and leads from ambient air temperature. A thermally conductive adhesive assists in achieving accurate surface temperature measurement.

pointer register

Figure 2 shows the internal register structure of the TMP100 and TMP101. The 8-bit pointer register of the TMP100 and TMP101 is used to address a given data register. The pointer register uses the two LSBs to identify which of the data registers should respond to a read or write command. Table 1 identifies the bits of the pointer register byte. Table 2 describes the pointer address of the registers available in the TMP100 and TMP101. Power-up reset value of P1/P0 is 00.

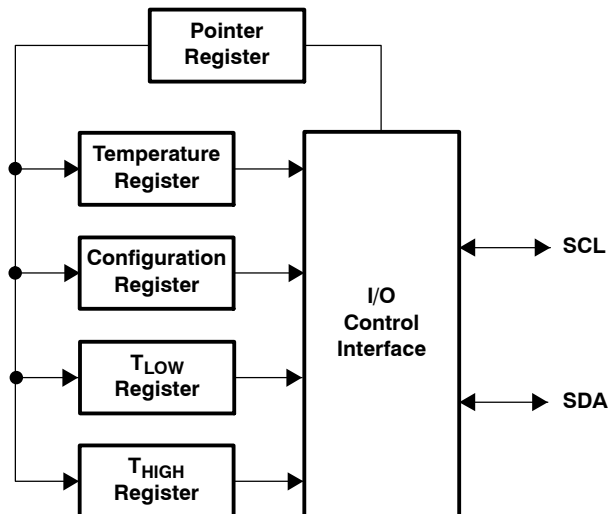

Figure 2. Internal Register Structure of TMP100 and TMP101

P7	P6	P5	P4	P3	P2	P1	P0
0	0	0	0	0	0	Register Bits	

Table 1. Pointer Register Byte

P1	P0	REGISTER
0	0	Temperature Register (READ Only)
0	1	Configuration Register (READ/WRITE)
1	0	T _{LOW} Register (READ/WRITE)
1	1	T _{HIGH} Register (READ/WRITE)

Table 2. Pointer Addresses of the TMP100 Registers

TMP100-EP DIGITAL TEMPERATURE SENSOR WITH I²C INTERFACE

SGLS254B – JULY 2005 – REVISED OCTOBER 2013

APPLICATION INFORMATION

temperature register

The temperature register of the TMP100 or TMP101 is a 12-bit read-only register that stores the output of the most recent conversion. Two bytes must be read to obtain data and are described in Table 3 and Table 4. The first 12 bits are used to indicate temperature with all remaining bits equal to zero. Data format for temperature is summarized in Table 5. Following power-up or reset, the temperature register reads 0°C until the first conversion is complete.

D7	D6	D5	D4	D3	D2	D1	D0
T11	T10	T9	T8	T7	T6	T5	T4

Table 3. Byte 1 of the Temperature Register

D7	D6	D5	D4	D3	D2	D1	D0
T3	T2	T1	T0	0	0	0	0

Table 4. Byte 2 of the Temperature Register

TEMPERATURE (°C)	DIGITAL OUTPUT (BINARY)	HEX
128	0111 1111 1111	7FF
127.9375	0111 1111 1111	7FF
100	0110 0100 0000	640
80	0101 0000 0000	500
75	0100 1011 0000	4B0
50	0011 0010 0000	320
25	0001 1001 0000	190
0.25	0000 0000 0100	004
0.0	0000 0000 0000	000
-0.25	1111 1111 1100	FFC
-25	1110 0111 0000	E70
-55	1100 1001 0000	C90
-128	1000 0000 0000	800

Table 5. Temperature Data Format

The user can obtain 9, 10, 11, or 12 bits of resolution by addressing the configuration register and setting the resolution bits accordingly. For 9, 10, or 11 bit resolution, the most significant bits in the temperature register are used with the unused LSBs set to zero.

APPLICATION INFORMATION

configuration register

The configuration register is an 8-bit read/write register used to store bits that control the operational modes of the temperature sensor. Read/write operations are performed MSB first. The format of the configuration register for the TMP100 and TMP101 is shown in Table 6, followed by a breakdown of the register bits. The power-up/reset value of the configuration register is all bits equal to 0. The OS/ALERT bit will read as 1 after power-up/reset.

Byte	D7	D6	D5	D4	D3	D2	D1	D0
1	OS/ALERT	R1	R0	F1	F0	POL	TM	SD

Table 6. Configuration Register Format

shutdown mode (SD)

The shutdown mode of the TMP100 and TMP101 allows the user to save maximum power by shutting down all device circuitry other than the serial interface, which reduces current consumption to less than 1 μ A. For the TMP100 and TMP101, shutdown mode is enabled when the SD bit is 1. The device shutsdown once the current conversion is completed. For SD equal to 0, the device maintains continuous conversion.

thermostat mode (TM)

The thermostat mode bit of the TMP101 indicates to the device whether to operate in comparator mode (TM = 0) or interrupt mode (TM = 1). For more information on comparator and interrupt modes, see the *high and low limit registers* and *SMBus alert function* sections.

polarity (POL)

The polarity bit of the TMP101 allows the user to adjust the polarity of the ALERT pin output. If POL = 0, the ALERT pin will be active low as shown in Figure 3. For POL = 1, the ALERT pin will be active high and the state of the ALERT pin is inverted.

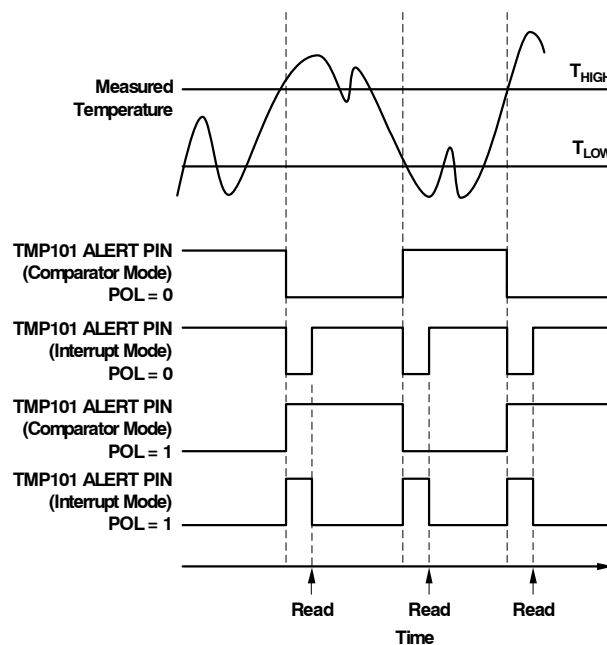

Figure 3. Output Transfer Function Diagrams

TMP100-EP DIGITAL TEMPERATURE SENSOR WITH I²C INTERFACE

SGLS254B – JULY 2005 – REVISED OCTOBER 2013

APPLICATION INFORMATION

fault queue (F1/F0)

A fault condition occurs when the measured temperature exceeds the limits set in the T_{HIGH} and T_{LOW} registers. Additionally, the number of fault conditions required to generate an alert may be programmed using the fault queue. The fault queue is provided to prevent a false alert due to environmental noise and requires consecutive fault measurements to trigger the alert function. Table 7 defines the number of measured faults that may be programmed to trigger an alert condition.

F1	F0	CONSECUTIVE FAULTS
0	0	1
0	1	2
1	0	4
1	1	6

Table 7. Fault Settings of the TMP100 and TMP101

converter resolution (R1/R0)

The converter resolution bits control the resolution of the internal analog-to-digital (A/D) converter. This allows the user to maximize efficiency by programming for higher resolution or faster conversion time. Table 8 identifies the resolution bits and relationship between resolution and conversion time.

R1	R0	RESOLUTION	CONVERSION TIME (Typical)
0	0	9 Bits (0.5°C)	40 ms
0	1	10 Bits (0.25°C)	80 ms
1	0	11 Bits (0.125°C)	160 ms
1	1	12 Bits (0.0625°C)	320 ms

Table 8. Resolution of the TMP100

os/alert (OS)

The TMP100 and TMP101 feature a one-shot temperature measurement mode. When the device is in shutdown mode, writing a 1 to the OS/ALERT bit starts a single temperature conversion. The device returns to the shutdown state at the completion of the single conversion. This is useful to reduce power consumption in the TMP100 and TMP101 when continuous monitoring of temperature is not required.

Reading the OS/ALERT bit provides information about the comparator mode status. The state of the POL bit will invert the polarity of data returned from the OS/ALERT bit. For POL = 0, the OS/ALERT reads as 1 until the temperature equals or exceeds T_{HIGH} for the programmed number of consecutive faults, causing the OS/ALERT bit to read as 0. The OS/ALERT bit continues to read as 0 until the temperature falls below T_{LOW} for the programmed number of consecutive faults when it again reads as 1. The status of the TM bit does not affect the status of the OS/ALERT bit.

APPLICATION INFORMATION

high and low limit registers

In comparator mode (TM = 0), the ALERT pin of the TMP101 becomes active when the temperature equals or exceeds the value in T_{HIGH} and generates a consecutive number of faults according to fault bits F1 and F0. The ALERT pin remains active until the temperature falls below the indicated T_{LOW} value for the same number of faults.

In Interrupt Mode (TM = 1) the ALERT Pin becomes active when the temperature equals or exceeds T_{HIGH} for a consecutive number of fault conditions. The ALERT pin remains active until a read operation of any register occurs or the device successfully responds to the SMBus Alert Response Address. The ALERT pin will also be cleared if the device is placed in Shutdown Mode. Once the ALERT pin is cleared, it will only become active again by the temperature falling below T_{LOW}. When the temperature falls below T_{LOW}, the ALERT pin becomes active and remains active until cleared by a read operation of any register or a successful response to the SMBus Alert Response Address. Once the ALERT pin is cleared, the above cycle repeats with the ALERT pin becoming active when the temperature equals or exceeds T_{HIGH}. The ALERT pin can also be cleared by resetting the device with the General Call Reset command. This also clears the state of the internal registers in the device returning the device to Comparator Mode (TM = 0).

The ALERT pin function for both operational modes is represented in Figure 3. Table 9 and Table 10 describe the format for the T_{HIGH} and T_{LOW} registers. Power-up reset values for T_{HIGH} and T_{LOW} are: T_{HIGH} = 80°C and T_{LOW} = 75°C. The format of the data for T_{HIGH} and T_{LOW} is the same as for the temperature register.

All 12 bits for the temperature, T_{HIGH}, and T_{LOW} registers are used in the comparisons for the ALERT function for all converter resolutions. The three LSBs in T_{HIGH} and T_{LOW} can affect the ALERT output even if the converter is configured for 9-bit resolution.

Byte	D7	D6	D5	D4	D3	D2	D1	D0
1	H11	H10	H9	H8	H7	H6	H5	H4

Byte	D7	D6	D5	D4	D3	D2	D1	D0
2	H3	H2	H1	H0	0	0	0	0

Table 9. Bytes 1 and 2 of T_{HIGH} Register

Byte	D7	D6	D5	D4	D3	D2	D1	D0
1	L11	L10	L9	L8	L7	L6	L5	L4

Byte	D7	D6	D5	D4	D3	D2	D1	D0
2	L3	L2	L1	L0	0	0	0	0

Table 10. Bytes 1 and 2 of T_{LOW} Register

TMP100-EP DIGITAL TEMPERATURE SENSOR WITH I²C INTERFACE

SGLS254B – JULY 2005 – REVISED OCTOBER 2013

APPLICATION INFORMATION

serial interface

The TMP100 and TMP101 operate only as slave devices on the I²C bus and SMBus. Connections to the bus are made via the open-drain I/O lines SDA and SCL. The TMP100 and TMP101 support the transmission protocol for fast (up to 400 kHz) and high-speed (up to 3.4 MHz) modes. All data bytes are transmitted most significant bit first.

serial bus address

To program the TMP100 and TMP101, the master must first address slave devices via a slave address byte. The slave address byte consists of seven address bits and a direction bit indicating the intent of executing a read or write operation.

The TMP100 features two address pins to allow up to eight devices to be addressed on a single I²C interface. Table 11 describes the pin logic levels used to properly connect up to eight devices. *Float* indicates the pin is left unconnected. The state of pins ADD0 and ADD1 is sampled on the first I²C bus communication and should be set prior to any activity on the interface.

ADD1	ADD0	SLAVE ADDRESS
0	0	1001000
0	Float	1001001
0	1	1001010
1	0	1001100
1	Float	1001101
1	1	1001110
Float	0	1001011
Float	1	1001111

Table 11. Address Pins and Slave Addresses for TMP100

The address pins of the TMP100 and TMP101 are read after reset or in response to an I²C address acquire request. Following a read, the state of the address pins is latched to minimize power dissipation associated with detection.



APPLICATION INFORMATION

bus overview

The device that initiates the transfer is called a *master* and the devices controlled by the master are *slaves*. The bus must be controlled by a master device that generates the serial clock (SCL), controls the bus access, and generates the START and STOP conditions.

To address a specific device, a START condition is initiated, indicated by pulling the data-line (SDA) from a high-to-low logic level while SCL is high. All slaves on the bus shift in the slave address byte, with the last bit indicating whether a read or write operation is intended. During the ninth clock pulse, the slave being addressed responds to the master by generating an acknowledge and pulling SDA low.

Data transfer is then initiated and sent over eight clock pulses followed by an acknowledge bit. During data transfer, SDA must remain stable while SCL is high, as any change in SDA while SCL is high will be interpreted as a control signal. Once all data has been transferred, the master generates a STOP condition indicated by pulling SDA from low-to-high, while SCL is high.

writing/reading to the TMP100 and TMP101

Accessing a particular register on the TMP100 and TMP101 is accomplished by writing the appropriate value to the pointer register. The value for the pointer register is the first byte transferred after the I²C slave address byte with the R/ \bar{W} bit low. Every write operation to the TMP100 and TMP101 requires a value for the pointer register. (See Figure 5.)

When reading from the TMP100 and TMP101, the last value stored in the pointer register by a write operation is used to determine which register is read by a read operation. To change the register pointer for a read operation, a new value must be written to the pointer register. This is accomplished by issuing an I²C slave address byte with the R/ \bar{W} bit low, followed by the pointer register byte. No additional data is required. The master can then generate a START condition and send the I²C slave address byte with the R/ \bar{W} bit high to initiate the read command. See Figure 6 for details of this sequence. If repeated reads from the same register are desired, it is not necessary to continually send the pointer register bytes as the TMP100 and TMP101 remembers the pointer register value until it is changed by the next write operation.

slave mode operations

The TMP100 and TMP101 can operate as slave receivers or slave transmitters.

slave receiver mode

The first byte transmitted by the master is the slave address, with the R/ \bar{W} bit low. The TMP100 or TMP101 then acknowledges reception of a valid address. The next byte transmitted by the master is the pointer register. The TMP100 or TMP101 then acknowledges reception of the pointer register byte. The next byte or bytes are written to the register addressed by the pointer register. The TMP100 and TMP101 acknowledge reception of each data byte. The master may terminate data transfer by generating a START or STOP condition.

slave transmitter mode

The first byte is transmitted by the master and is the slave address, with the R/ \bar{W} bit high. The slave acknowledges reception of a valid slave address. The next byte is transmitted by the slave and is the most significant byte of the register indicated by the pointer register. The master acknowledges reception of the data byte. The next byte transmitted by the slave is the least significant byte. The master acknowledges reception of the data byte. The master may terminate data transfer by generating a not-acknowledge on reception of any data byte, or generating a START or STOP condition.

TMP100-EP DIGITAL TEMPERATURE SENSOR WITH I²C INTERFACE

SGLS254B – JULY 2005 – REVISED OCTOBER 2013

APPLICATION INFORMATION

SMBus alert function

The TMP101 supports the SMBus Alert function. When the TMP101 is operating in Interrupt Mode (TM = 1), the ALERT pin of the TMP101 may be connected as an SMBus Alert signal. When a master senses that an ALERT condition is present on the ALERT line, the master sends an SMBus Alert command (00011001) on the bus. If the ALERT pin of the TMP101 is active, the TMP101 acknowledges the SMBus Alert command and responds by returning its slave address on the SDA line. The eighth bit (LSB) of the slave address byte indicates if the temperature exceeding T_{HIGH} or falling below T_{LOW} caused the ALERT condition. For POL = 0, this bit will be LOW if the temperature is greater than or equal to T_{HIGH} . This bit will be HIGH if the temperature is less than T_{LOW} . The polarity of this bit will be inverted if POL = 1. See Figure 7 for details of this sequence.

If multiple devices on the bus respond to the SMBus Alert command, arbitration during the slave address portion of the SMBus alert command determines which device clears its ALERT status. If the TMP101 wins the arbitration, its ALERT pin becomes inactive at the completion of the SMBus Alert command. If the TMP101 loses the arbitration, its ALERT pin remains active.

The TMP100 also responds to the SMBus ALERT command if its TM bit is set to 1. Since it does not have an ALERT pin, the master needs to periodically poll the device by issuing an SMBus Alert command. If the TMP100 has generated an ALERT, it acknowledges the SMBus Alert command and returns its slave address in the next byte.

general call

The TMP100 and TMP101 respond to the I²C General Call address (0000000) if the eighth bit is 0. The device acknowledges the general call address and responds to commands in the second byte. If the second byte is 00000100, the TMP100 and TMP101 latch the status of their address pins, but will not reset. If the second byte is 00000110, the TMP100 and TMP101 latch the status of their address pins and reset their internal registers.

high-speed mode

In order for the I²C bus to operate at frequencies above 400 kHz, the master device must issue an Hs-mode master code (00001XXX) as the first byte after a START condition to switch the bus to high-speed operation. The TMP100 and TMP101 will not acknowledge this byte as required by the I²C specification, but switch their input filters on SDA and SCL and their output filters on SDA to operate in Hs-mode, allowing transfers at up to 3.4 MHz. After the Hs-mode master code has been issued, the master transmits an I²C slave address to initiate a data transfer operation. The bus continues to operate in Hs-mode until a STOP condition occurs on the bus. Upon receiving the STOP condition, the TMP100 and TMP101 switch their input and output filters back to fast-mode operation.

timing diagrams

The TMP100 and TMP101 are I²C and SMBus compatible. Figure 4 through Figure 7 describe the various operations on the TMP100 and TMP101. Bus definitions are given below. Parameters for Figure 4 are defined in Table 12.

Bus Idle: Both SDA and SCL lines remain high.

Start Data Transfer: A change in the state of the SDA line, from high-to-low, while the SCL line is high, defines a START condition. Each data transfer is initiated with a START condition.

Stop Data Transfer: A change in the state of the SDA line from low-to-high while the SCL line is high defines a STOP condition. Each data transfer is terminated with a repeated START or STOP condition.

Data Transfer: The number of data bytes transferred between a START and a STOP condition is not limited and is determined by the master device. The receiver acknowledges the transfer of data.



POST OFFICE BOX 655303 • DALLAS, TEXAS 75265

APPLICATION INFORMATION

Acknowledge: Each receiving device, when addressed, is obliged to generate an acknowledge bit. A device that acknowledges must pull down the SDA line during the Acknowledge clock pulse in such a way that the SDA line is stable low during the high period of the acknowledge clock pulse. Setup and hold times must be taken into account. On a master receive, the termination of the data transfer can be signaled by the master generating a not-acknowledge on the last byte that has been transmitted by the slave.

PARAMETER	FAST MODE		HIGH-SPEED MODE		UNIT
	MIN	MAX	MIN	MAX	
f _(SCLK) SCLK operating frequency		0.4		3.4	MHz
t _(BUF) Bus free time between STOP and START condition	600		160		ns
t _{h(STA)} Hold time after repeated START condition. After this period, the first clock is generated.	600		160		ns
t _{su(STA)} Repeated START condition setup time	600		160		ns
t _{su(STO)} STOP condition setup time	600		160		ns
t _{h(DAT)} Data hold time	0		0		ns
t _{su(DAT)} Data setup time	100		10		ns
t _(LOW) SCLK clock low period	1300		160		ns
t _(HIGH) SCLK clock high period	600		60		ns
t _f Clock/data fall time		300		160	ns
t _r Clock/data rise time		300		160	ns

Table 12. Timing Diagram Definitions

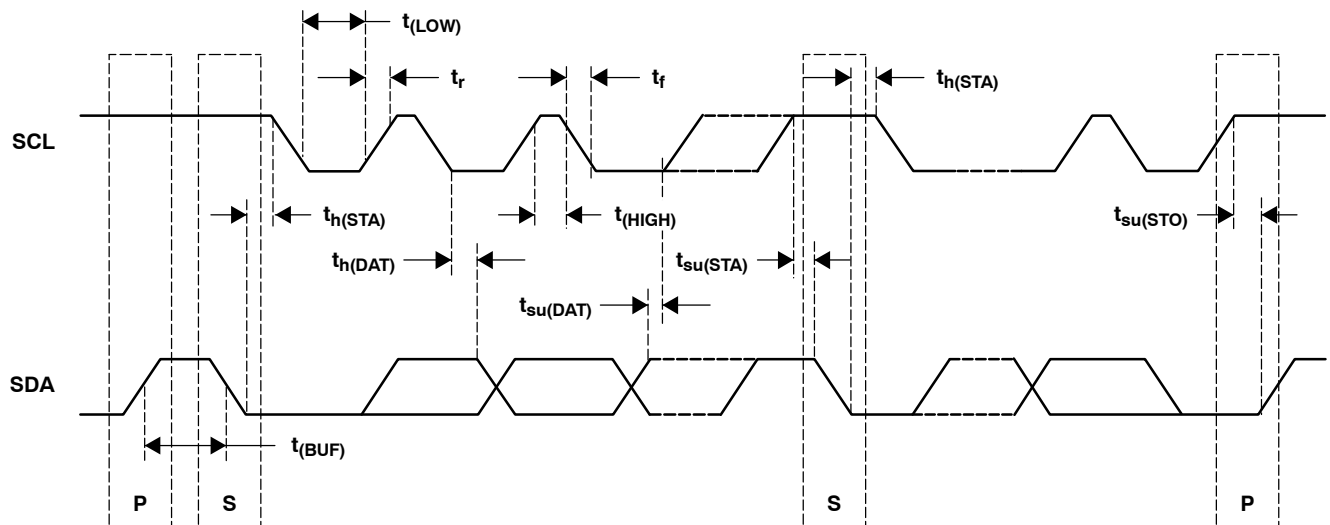

Figure 4. I²C Timing Diagram

TMP100-EP DIGITAL TEMPERATURE SENSOR WITH I²C INTERFACE

SGLS254B – JULY 2005 – REVISED OCTOBER 2013

APPLICATION INFORMATION

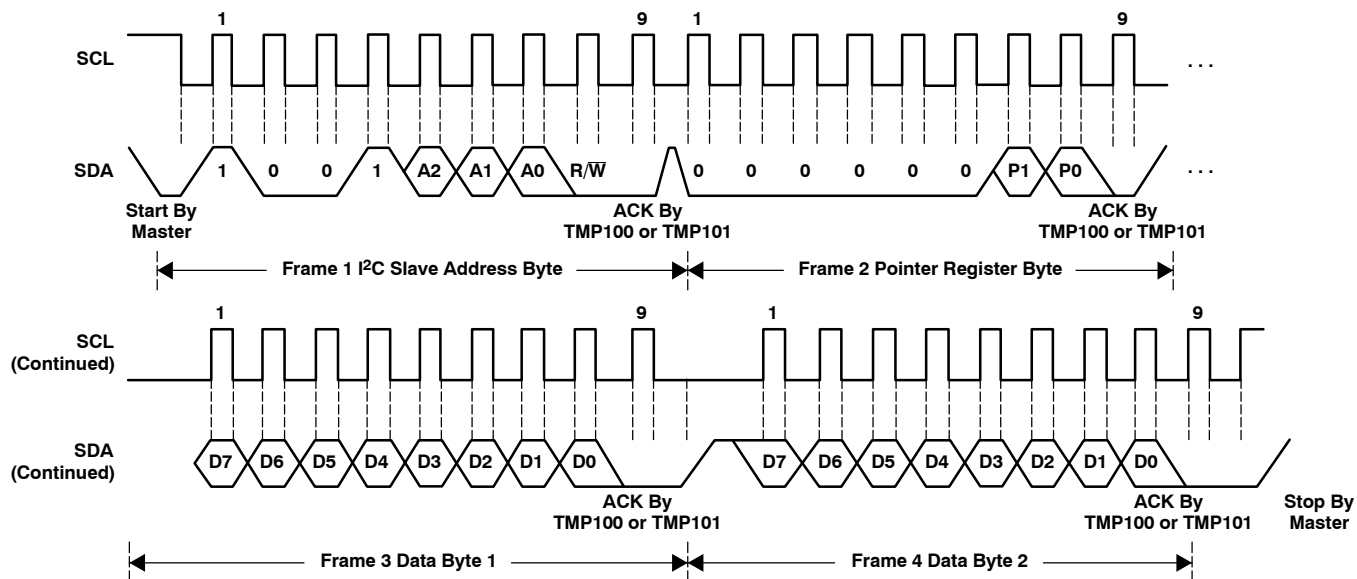

Figure 5. I²C Timing Diagram for Write Word Format

APPLICATION INFORMATION

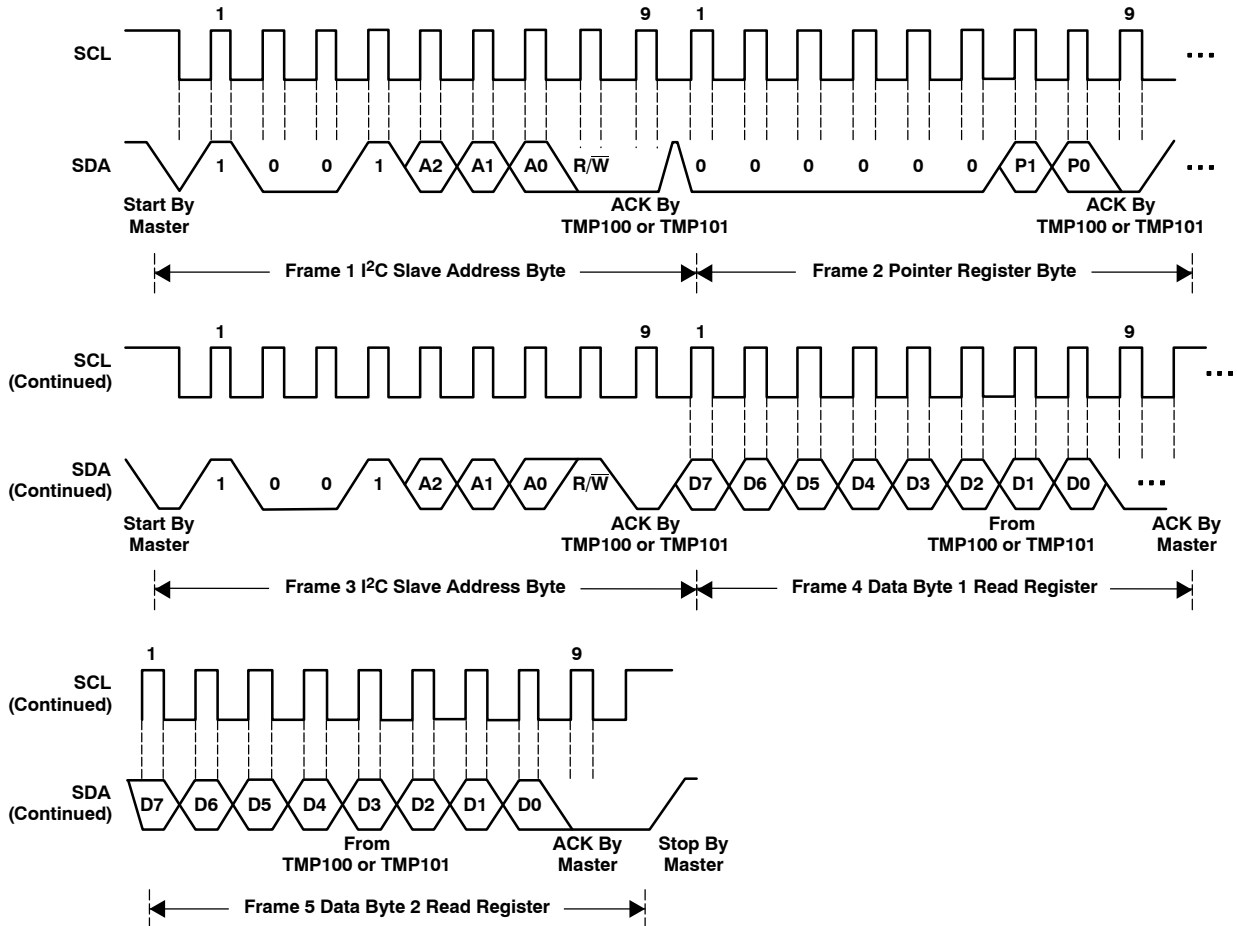

Figure 6. I²C Timing Diagram for Read Word Format

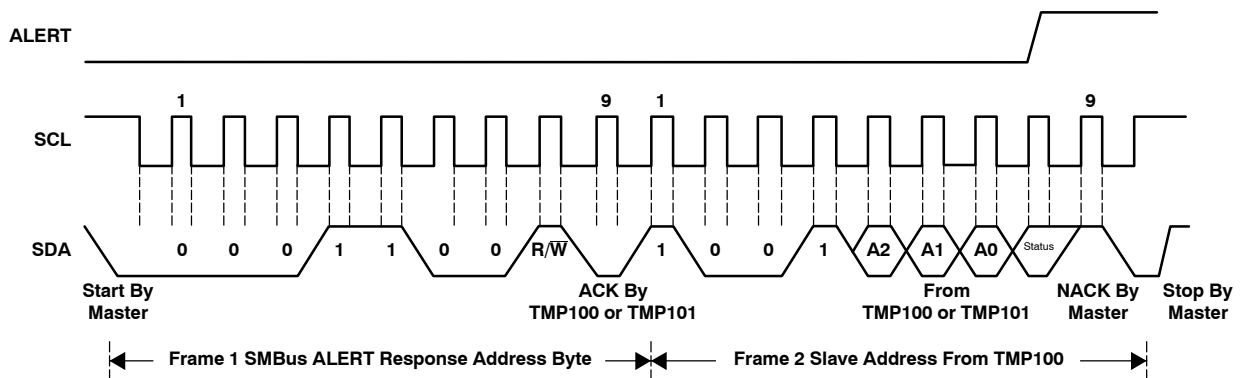

Figure 7. Timing Diagram for SMBus ALERT

TMP100-EP DIGITAL TEMPERATURE SENSOR WITH I²C INTERFACE

SGLS254B – JULY 2005 – REVISED OCTOBER 2013

TYPICAL CHARACTERISTICS, at T_A = 25°C, V₊ = 5 V, UNLESS OTHERWISE NOTED

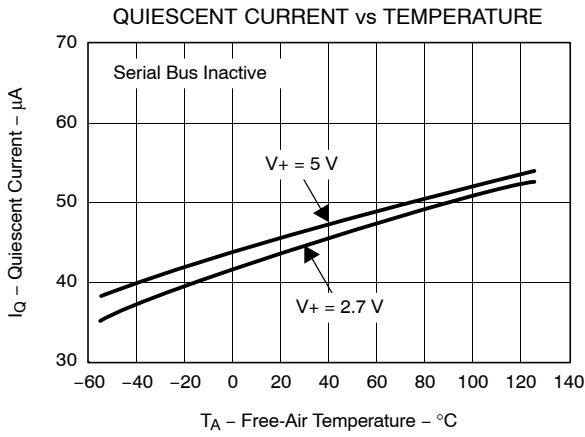

Figure 8

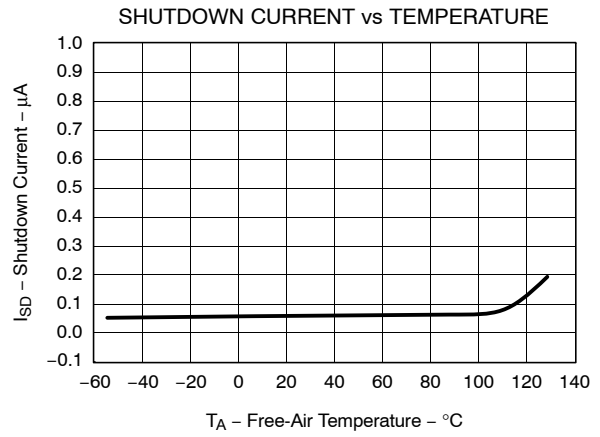

Figure 9

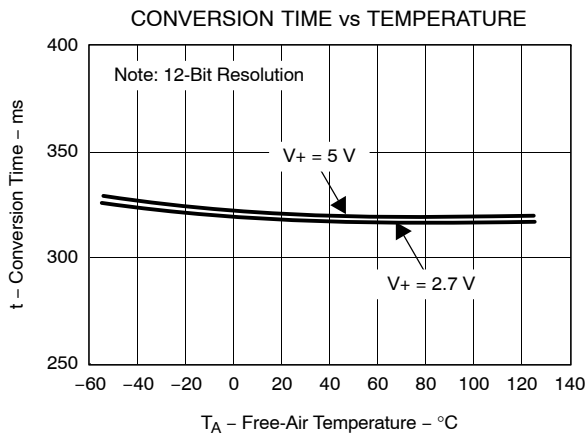

Figure 10

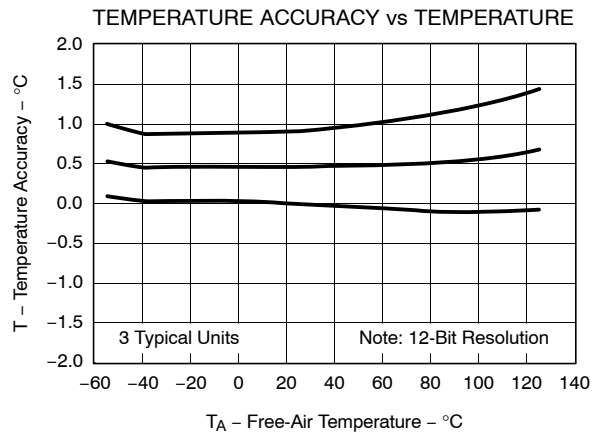

Figure 11

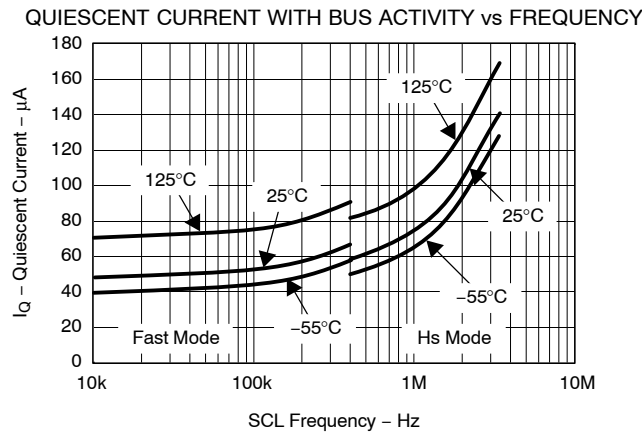

Figure 12



Revision History

DATE	REV	PAGE	SECTION	DESCRIPTION
10-04-13	B	10	serial bus address	deleted Table 12 and first 2 sentences in paragraph above the table
09-30-13	B	Document	Multiple sections throughout document	Changed to Rev B October 2013. Corrected only what was marked in red.

NOTE: Page numbers for previous revisions may differ from page numbers in the current version.

PACKAGING INFORMATION

Orderable Device	Status (1)	Package Type	Package Drawing	Pins	Package Qty	Eco Plan (2)	Lead/Ball Finish (6)	MSL Peak Temp (3)	Op Temp (°C)	Device Marking (4/5)	Samples
TMP100MDBVREP	ACTIVE	SOT-23	DBV	6	3000	Green (RoHS & no Sb/Br)	CU NIPDAU	Level-2-260C-1 YEAR	-55 to 125	100E	Samples
V62/05618-01XE	ACTIVE	SOT-23	DBV	6	3000	Green (RoHS & no Sb/Br)	CU NIPDAU	Level-2-260C-1 YEAR	-55 to 125	100E	Samples

(1) The marketing status values are defined as follows:

ACTIVE: Product device recommended for new designs.

LIFEBUY: TI has announced that the device will be discontinued, and a lifetime-buy period is in effect.

NRND: Not recommended for new designs. Device is in production to support existing customers, but TI does not recommend using this part in a new design.

PREVIEW: Device has been announced but is not in production. Samples may or may not be available.

OBSOLETE: TI has discontinued the production of the device.

(2) Eco Plan - The planned eco-friendly classification: Pb-Free (RoHS), Pb-Free (RoHS Exempt), or Green (RoHS & no Sb/Br) - please check <http://www.ti.com/productcontent> for the latest availability information and additional product content details.

TBD: The Pb-Free/Green conversion plan has not been defined.

Pb-Free (RoHS): TI's terms "Lead-Free" or "Pb-Free" mean semiconductor products that are compatible with the current RoHS requirements for all 6 substances, including the requirement that lead not exceed 0.1% by weight in homogeneous materials. Where designed to be soldered at high temperatures, TI Pb-Free products are suitable for use in specified lead-free processes.

Pb-Free (RoHS Exempt): This component has a RoHS exemption for either 1) lead-based flip-chip solder bumps used between the die and package, or 2) lead-based die adhesive used between the die and leadframe. The component is otherwise considered Pb-Free (RoHS compatible) as defined above.

Green (RoHS & no Sb/Br): TI defines "Green" to mean Pb-Free (RoHS compatible), and free of Bromine (Br) and Antimony (Sb) based flame retardants (Br or Sb do not exceed 0.1% by weight in homogeneous material)

(3) MSL, Peak Temp. - The Moisture Sensitivity Level rating according to the JEDEC industry standard classifications, and peak solder temperature.

(4) There may be additional marking, which relates to the logo, the lot trace code information, or the environmental category on the device.

(5) Multiple Device Markings will be inside parentheses. Only one Device Marking contained in parentheses and separated by a "~" will appear on a device. If a line is indented then it is a continuation of the previous line and the two combined represent the entire Device Marking for that device.

(6) Lead/Ball Finish - Orderable Devices may have multiple material finish options. Finish options are separated by a vertical ruled line. Lead/Ball Finish values may wrap to two lines if the finish value exceeds the maximum column width.

Important Information and Disclaimer: The information provided on this page represents TI's knowledge and belief as of the date that it is provided. TI bases its knowledge and belief on information provided by third parties, and makes no representation or warranty as to the accuracy of such information. Efforts are underway to better integrate information from third parties. TI has taken and continues to take reasonable steps to provide representative and accurate information but may not have conducted destructive testing or chemical analysis on incoming materials and chemicals. TI and TI suppliers consider certain information to be proprietary, and thus CAS numbers and other limited information may not be available for release.

In no event shall TI's liability arising out of such information exceed the total purchase price of the TI part(s) at issue in this document sold by TI to Customer on an annual basis.

OTHER QUALIFIED VERSIONS OF TMP100-EP :

- Catalog: [TMP100](#)

NOTE: Qualified Version Definitions:

- Catalog - TI's standard catalog product

TAPE AND REEL INFORMATION

QUADRANT ASSIGNMENTS FOR PIN 1 ORIENTATION IN TAPE

*All dimensions are nominal

Device	Package Type	Package Drawing	Pins	SPQ	Reel Diameter (mm)	Reel Width W1 (mm)	A0 (mm)	B0 (mm)	K0 (mm)	P1 (mm)	W (mm)	Pin1 Quadrant
TMP100MDBVREP	SOT-23	DBV	6	3000	180.0	8.4	3.2	3.1	1.39	4.0	8.0	Q3

TAPE AND REEL BOX DIMENSIONS



*All dimensions are nominal

Device	Package Type	Package Drawing	Pins	SPQ	Length (mm)	Width (mm)	Height (mm)
TMP100MDBVREP	SOT-23	DBV	6	3000	210.0	185.0	35.0

MECHANICAL DATA

DBV (R-PDSO-G6)

PLASTIC SMALL-OUTLINE PACKAGE

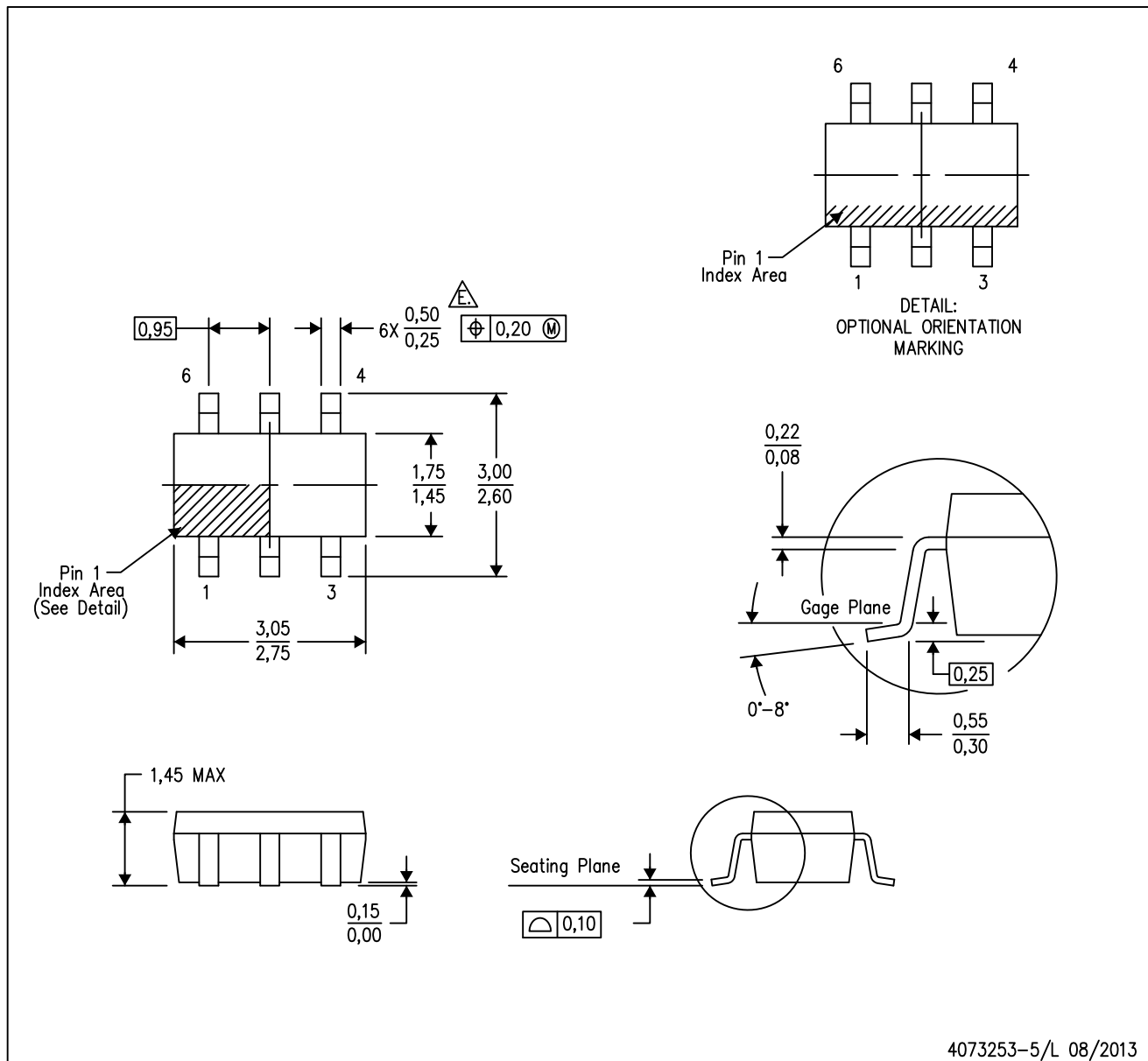

- NOTES:
- A. All linear dimensions are in millimeters.
 - B. This drawing is subject to change without notice.
 - C. Body dimensions do not include mold flash or protrusion. Mold flash and protrusion shall not exceed 0.15 per side.
 - D. Leads 1,2,3 may be wider than leads 4,5,6 for package orientation.
-  Falls within JEDEC MO-178 Variation AB, except minimum lead width.

DBV (R-PDSO-G6)

PLASTIC SMALL OUTLINE



- NOTES:
- A. All linear dimensions are in millimeters.
 - B. This drawing is subject to change without notice.
 - C. Customers should place a note on the circuit board fabrication drawing not to alter the center solder mask defined pad.
 - D. Publication IPC-7351 is recommended for alternate designs.
 - E. Laser cutting apertures with trapezoidal walls and also rounding corners will offer better paste release. Customers should contact their board assembly site for stencil design recommendations. Example stencil design based on a 50% volumetric metal load solder paste. Refer to IPC-7525 for other stencil recommendations.

IMPORTANT NOTICE

Texas Instruments Incorporated and its subsidiaries (TI) reserve the right to make corrections, enhancements, improvements and other changes to its semiconductor products and services per JESD46, latest issue, and to discontinue any product or service per JESD48, latest issue. Buyers should obtain the latest relevant information before placing orders and should verify that such information is current and complete. All semiconductor products (also referred to herein as "components") are sold subject to TI's terms and conditions of sale supplied at the time of order acknowledgment.

TI warrants performance of its components to the specifications applicable at the time of sale, in accordance with the warranty in TI's terms and conditions of sale of semiconductor products. Testing and other quality control techniques are used to the extent TI deems necessary to support this warranty. Except where mandated by applicable law, testing of all parameters of each component is not necessarily performed.

TI assumes no liability for applications assistance or the design of Buyers' products. Buyers are responsible for their products and applications using TI components. To minimize the risks associated with Buyers' products and applications, Buyers should provide adequate design and operating safeguards.

TI does not warrant or represent that any license, either express or implied, is granted under any patent right, copyright, mask work right, or other intellectual property right relating to any combination, machine, or process in which TI components or services are used. Information published by TI regarding third-party products or services does not constitute a license to use such products or services or a warranty or endorsement thereof. Use of such information may require a license from a third party under the patents or other intellectual property of the third party, or a license from TI under the patents or other intellectual property of TI.

Reproduction of significant portions of TI information in TI data books or data sheets is permissible only if reproduction is without alteration and is accompanied by all associated warranties, conditions, limitations, and notices. TI is not responsible or liable for such altered documentation. Information of third parties may be subject to additional restrictions.

Resale of TI components or services with statements different from or beyond the parameters stated by TI for that component or service voids all express and any implied warranties for the associated TI component or service and is an unfair and deceptive business practice. TI is not responsible or liable for any such statements.

Buyer acknowledges and agrees that it is solely responsible for compliance with all legal, regulatory and safety-related requirements concerning its products, and any use of TI components in its applications, notwithstanding any applications-related information or support that may be provided by TI. Buyer represents and agrees that it has all the necessary expertise to create and implement safeguards which anticipate dangerous consequences of failures, monitor failures and their consequences, lessen the likelihood of failures that might cause harm and take appropriate remedial actions. Buyer will fully indemnify TI and its representatives against any damages arising out of the use of any TI components in safety-critical applications.

In some cases, TI components may be promoted specifically to facilitate safety-related applications. With such components, TI's goal is to help enable customers to design and create their own end-product solutions that meet applicable functional safety standards and requirements. Nonetheless, such components are subject to these terms.

No TI components are authorized for use in FDA Class III (or similar life-critical medical equipment) unless authorized officers of the parties have executed a special agreement specifically governing such use.

Only those TI components which TI has specifically designated as military grade or "enhanced plastic" are designed and intended for use in military/aerospace applications or environments. Buyer acknowledges and agrees that any military or aerospace use of TI components which have **not** been so designated is solely at the Buyer's risk, and that Buyer is solely responsible for compliance with all legal and regulatory requirements in connection with such use.

TI has specifically designated certain components as meeting ISO/TS16949 requirements, mainly for automotive use. In any case of use of non-designated products, TI will not be responsible for any failure to meet ISO/TS16949.

Products

Audio	www.ti.com/audio
Amplifiers	amplifier.ti.com
Data Converters	dataconverter.ti.com
DLP® Products	www.dlp.com
DSP	dsp.ti.com
Clocks and Timers	www.ti.com/clocks
Interface	interface.ti.com
Logic	logic.ti.com
Power Mgmt	power.ti.com
Microcontrollers	microcontroller.ti.com
RFID	www.ti-rfid.com
OMAP Applications Processors	www.ti.com/omap
Wireless Connectivity	www.ti.com/wirelessconnectivity

Applications

Automotive and Transportation	www.ti.com/automotive
Communications and Telecom	www.ti.com/communications
Computers and Peripherals	www.ti.com/computers
Consumer Electronics	www.ti.com/consumer-apps
Energy and Lighting	www.ti.com/energy
Industrial	www.ti.com/industrial
Medical	www.ti.com/medical
Security	www.ti.com/security
Space, Avionics and Defense	www.ti.com/space-avionics-defense
Video and Imaging	www.ti.com/video

TI E2E Community

e2e.ti.com