

THIS DRAWING IS UNPUBLISHED. RELEASED FOR PUBLICATION
 © COPYRIGHT - By - ALL RIGHTS RESERVED.

LOC	DIST	REVISIONS					
		P	LTR	DESCRIPTION	DATE	DWN	APVD
G	14		L2	REVISED PER ECO-14-016783	06NOV2014	NK	DR

AMP WIRE RANGE	Listed FILE E13288	LR7189 Certified
22-16 AWG SOLID OR STRANDED	22-16 AWG SOLID OR STRANDED	22-16 AWG SOLID OR STRANDED

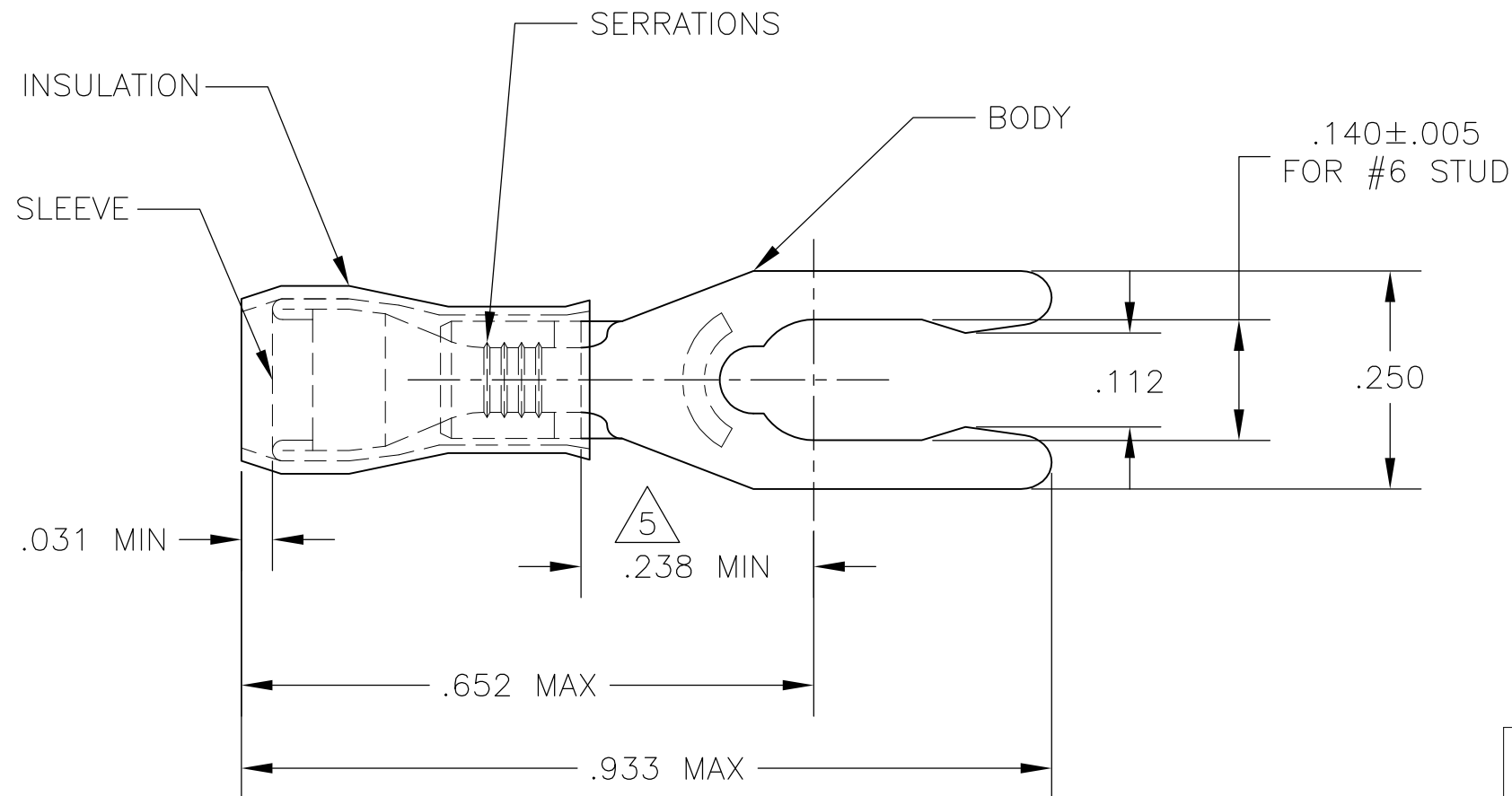

- 1 STAMP 6S AMP 22-18* APPROX AS SHOWN
22-16 TERMINALS ARE STAMPED 22-18 IN
ACCORDANCE WITH MILITARY SPEC SAE AS 7928
COMMERCIAL WIRE RANGE IS 22-16.
- 2 WIRE INSULATION DIA: DIM "A", SEE TABLE.
- 3 TONGUE MATERIAL THK: .031±.002.
- 4 MATERIAL: BODY - PHOS BRONZE PER ASTM B103
TIN PLATE PER ASTM B545
SLEEVE - CU PER ASTM B152
TIN PLATE PER ASTM B545
INSULATION - NYLON, COLOR - RED.
- 5 APPLIES FROM THE METAL EDGE OF BARREL TO
CENTERLINE OF STUD.

.080-.125	100	52409 IN BOX	8-52409-1
.105-.140	5000	52409-2 ON TAPE, REEL	52409-3
.105-.140	1	LOOSE PIECE	52409-2
.080-.125	5000	52409 ON TAPE, REEL	52409-1
.080-.125	1	LOOSE PIECE	52409
"A"	QTY	PACKAGING TYPE	PART NO.

CUSTOMER SERVICE SYSTEMS		MAX RECOMMENDED OPERATING TEMPERATURE: 105°C [221°F]	THIS DRAWING IS A CONTROLLED DOCUMENT.		DWN JR RUTH 10DEC09	TE Connectivity			
FOR ADDITIONAL PRODUCT INFORMATION OR COPIES OF DRAWINGS AND TECHNICAL DOCUMENTS	PRODUCT INFORMATION CENTER 1-800-522-6752	VOLTAGE RATING: 300 V MAX	DIMENSIONS: INCHES	TOLERANCES UNLESS OTHERWISE SPECIFIED:	CHK TOM MICHIELUTTI 10DEC09				NAME TOM MICHIELUTTI
FOR APPLICATION TOOLING INFORMATION	TOOLING ASSISTANCE CENTER 1-800-722-1111	CIRCULAR MIL AREA: 0.26-1.65mm² [509-3260] SOLID OR STRANDED		0 PLC ± - 1 PLC ± - 2 PLC ± .008 3 PLC ± - 4 PLC ± - ANGLES ± -	APVD TOM MICHIELUTTI 10DEC09	PRODUCT SPEC 108-1034			
FOR ORDER ENTRY	1-800-526-5142		MATERIAL 	FINISH TIN PL PER ASTM B-545	PRODUCT SPEC NOT AVAILABLE	SIZE A3	CAGE CODE 00779	DRAWING NO C-52409	RESTRICTED TO -
					WEIGHT -	SCALE 4:1		SHEET 1 OF 1	REV L2